

## MANUFACTURING TECHNIQUES OF FULL SCALE CRAB CAVITIES AND A SIMPLIFIED CO-AXIAL COUPLER FOR KEKB

H.Hattori<sup>#</sup>, M.Inoue, K.Ohkubo, K.Sennyu, T.Yamanaka, MHI\*, 1-1-1, Wadasaki-cho, Hyogo-ku, Kobe, 652-8585, Japan, Y.Taura, MHI, 4-6-22, Kannon-cho, Nishi-ku, Hiroshima, 733-8553, Japan, T.Ohta, MHI, 2-1-1, Nihama, Arai-cho, Takasago, 676-8686, Japan, K. Hosoyama, T.Nakai, KEK<sup>+</sup>, 1-1, Oho, Tsukuba, Ibaraki, 305-0801, Japan

### Abstract

Since 1995, Manufacturing techniques of superconducting Nb cavity have been developed on R&D of Crab Cavity for KEK-B at MHI. Especially the Roll Forming process is applicable to accuracy seamless Nb pipe for Co-axial Coupler. With the parameters optimized in short sample, we produced 850mm-long pipes.

### 1 INTRODUCTION

KEK B-factory (KEKB), a high luminosity  $8 \times 3.5$  GeV asymmetric electron-positron collider, which started operation last year, adopted a finite angle crossing scheme of  $2 \times 11$  mrad at the interaction point. The crab crossing scheme shown Fig.1 was proposed to eliminate the luminosity reduction due to geometrical effect and the possibility of beam-beam instability by synchrotron-betatron coupling resonances. Electron and positron bunches to the interaction point are tilted by time-dependent transverse kick in RF crab cavities and head-on collide. After the collision these bunches are kicked back to the original position in another crab cavities. The crab cavity has non-axially symmetric squashed cell shape[1] to get the TM<sub>110</sub> like mode for time-dependent transverse kick and complex co-axial coupler extracting unwanted higher and lower modes.

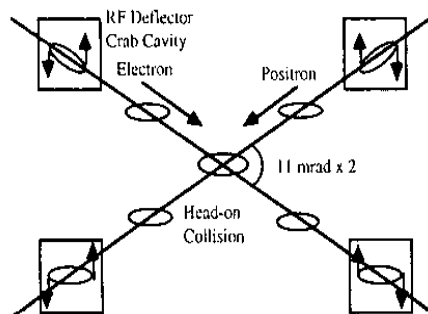

Figure 1: Crab crossing scheme for KEKB

Since 1995, the niobium superconducting crab cavities have been developed with collaboration between MHI and KEK[2]. In this R&D, MHI has taken manufacturing part of superconducting Nb cavity. We fabricated three 1/3 scale model cavities and two simplified co-axial couplers to establish the fabrication and surface treatment techniques for non-axially symmetric Nb cavity and accuracy coupler, two full scale model cavities to prove the performance over the design value of  $E_{sp} = 21$  MV/m.

### 2 FABRICATION AND SURFACE TREATMENT OF NB CRAB CAVITY

The fabrication and surface treatment procedure of the crab cavities is summarized in Fig.2. For half cell, Niobium material, sheets of 5 mm in thickness with  $RRR = 190$ , was supplied from Tokyo Denkai. Half cells were formed by a hydro-forming method. All formed half cells were buff-polished inside to remove the scars on it and the equator and iris parts of cells were trimmed mechanically. After these half cells were immersed into hydrochloric acid in order to remove iron particles and surface of grooves were chemical polished to remove other materials, couples of half cells were assembled by Electron beam welding (EBW) at the equator from the outside. EBW seams were mechanically ground and visually inspected by specially designed grinding and inspecting tool. Then the cells and beam pipes were assembled into cavities on the same process, and the cavities were buffing the inside of beam pipe. After Pre-tuning, inner surface of the cavities were barrel polished more than about  $200\mu\text{m}$  and then electro polished about  $100\mu\text{m}$  by horizontal rotational electro polishing system developed and used for TRISTAN superconducting cavity.[3] After rinsing by ultra pure water, the cavities were installed in a titanium box and annealed in a vacuum at a pressure of  $10^{-3}$  Pa at  $700\text{C}^\circ$  for 1.5 hours. Finally inner surface of the cavities were high pressure rinsed by 8 MPa ultra pure water for about 45 min.

<sup>#</sup> E-mail: [hisashi\\_hattori@kind.kobe.mhi.co.jp](mailto:hisashi_hattori@kind.kobe.mhi.co.jp)

\* Mitsubishi Heavy Industries, Ltd.

<sup>+</sup> High Energy Accelerator Research Organization

- Fabrication processes of Crab Cavity
1. Nb sheets (RRR=180)
  2. Hydro-forming of half cells  
Load=2000ton
  3. Buffing the inside surface of half cell
  4. Machining of grooves of half cells
  5. Water dipping and HCl dipping of half cell
  6. Chemical Polishing surface of grooves
  7. EB welding of the equator of cells
  8. Grinding the penetration bead
  9. EB welding of the both side beam pipe
  10. Buffing the inside surface of beam pipe
  11. Pre-turning
  12. EB welding of ribs
  13. Barrel polishing (200 $\mu$ m)
  14. Electro polishing (100 $\mu$ m)
  15. High pressure water rinsing (80kg/cm<sup>2</sup>)
  16. Vacuum heat treatment (700°C for 90 min)
  17. High pressure water rinsing (80kg/cm<sup>2</sup> for 45 min)
  18. Assembling in the clean room for vertical test (class 10 clean room)
  19. Vertical test

Figure 2: The fabrication and surface treatment procedure of the crab cavity

### 3 FABRICATION AND SURFACE TREATMENT OF NB SIMPLIFIED CO-AXIAL COUPLER

The fabrication and surface treatment procedure of the Co-axial coupler is summarized in Fig.3. For beam pipe, Niobium material, rods of 154 mm in diameter with RRR = 180, was supplied from Tokyo Denkai. The rods were bored to pipes by wire-EDM, and the pipes were machined to original pipes 12 mm in thickness. Then the pipes were elongated and reduced in wall thickness 2.85mm by flow-forming, which is one of the roll forming method. These pipes were buff-polished outside to remove the scars on it and the both end of the pipes were trimmed mechanically. After these pipes were dipped into hydrochloric acid in order to remove iron particles and surface of grooves were chemical polished to remove other materials, pipes and flanges were assembled into simplified co-axial couplers by Electron beam welding (EBW) from the outside. EBW seams were mechanically ground and visually inspected. Then the coupler was electro polished about 100  $\mu$ m by vertical electro

polishing system. Finally outer surface of the coupler was high pressure rinsed by 8 MPa ultra pure water for about 45 min.

- Fabrication processes of Simplified Co-Axial coupler
1. Nb rods (RRR=180)
  2. Boring by wire-EDM
  3. Machining to original pipe (12mm)
  4. Flow-forming
  5. Vacuum heat treatment
  6. Flow-forming the accuracy seamless pipe (2.85 mm)
  7. Buffing the outside surface of pipe
  8. Chemical Polishing surface of grooves
  9. EB welding of the both fringe
  10. Electro polishing (100 $\mu$ m)
  11. High pressure water rinsing (80kg/cm<sup>2</sup> for 45 min)
  12. Assembling the Simplified co-axial coupler and the Crab cavity(class 10 clean room)
  13. Assembling for vertical test (class 10 clean room)
  14. Vertical test

Figure 3: The fabrication and surface treatment procedure of the simplified co-axial coupler

### 4 HYDRO-FORMING

#### 4.1 Hydro-forming method

The crab cavity has the non-axially symmetric cell. We took the Hydro-forming method for forming these half cells in consideration of the merits of hydro-forming method. The merits are as follows.

- The female die shape can be simple.
- The fabrication error of forming cell can be reduced.
- The forming can be done at larger percentage reduction of cross-sectional area.

Hydro-forming set up is shown in Fig.4.

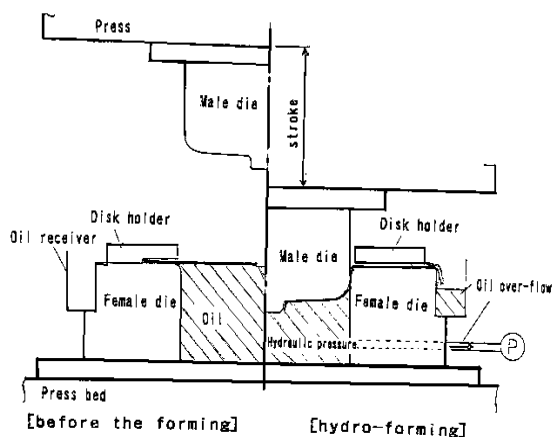

Figure 4: The hydro-forming set up

#### 4.2 Development of flow-forming Hydro-forming process

At first, we did the 1/3 scale forming test with aluminum sheet and optimized parameter of blank size, hydraulic pressure and stroke. Then we confirmed that Nb half cells of 1/3 scale model were formed fine, and the parameters scaled to full scale cavity. After full scale forming test with aluminum, we formed Nb half cells of full scale cavities and confirmed forming them fine. The parameters are as follows.

- load : 2,000 ton
- hydraulic pressure : 140 kg/cm<sup>2</sup>

## 5 FLOW-FORMING

### 5.1 Necessity of accuracy pipe

The Co-axial Coupler requires a narrow manufacturing error. The misalignment and manufacturing error of the Co-axial Coupler causes a part of the crabbing mode to couple to the Co-axial Coupler as a TEM mode wave. So in order to reduce manufacturing error, we developed accuracy beam pipe by flow-forming.

### 5.2 Flow-forming method

The flow-forming method is one of the spinning forming. By sliding and rotating the three rolls along the material which is clamped to the mandrel at the tailstock (see Fig.5.), the material is elongated and formed a thin pipe. With this method, we can obtain good thickness, circularity and straightness control of pipe.

thin accuracy beam pipe (after forming)

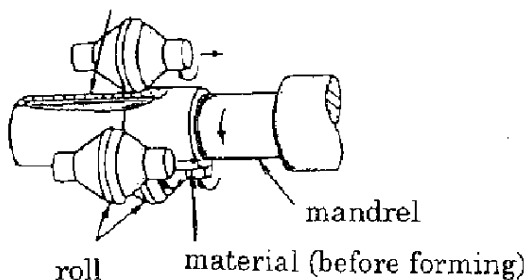

Figure 5: The flow-forming method

### 5.2 Development of flow-forming process

At first, we did the forming test with Nb 100 mm long sample to search for the important parameter in flow-forming. For niobium, the crystal size of material and reduction rate were important at sample test and we optimized parameter of crystal size, reduction rate, sliding speed and rotating speed. The  $\phi$  154 mm x  $\perp$  250 mm rods were bored to pipes by wire-EDM and machined to  $\phi$  148 mm x  $\perp$  12 mm original pipes. These pipes were flow-formed several steps to  $\phi$  130 mm x  $\perp$  2.85 mm x  $\perp$  850 mm accuracy pipes. Manufacturing deviation of one pipe is shown in Table 1.

Table 1: The result of flow-forming pipe

| Dimension    | Design value | Tolerance      | Result         |
|--------------|--------------|----------------|----------------|
| Thickness    | 2.85 mm      | -0.10<br>+0.10 | -0.01<br>+0.09 |
| Circularity  | 130 mm       | 0.20 mm        | 0.14 mm        |
| Straightness | 850 mm       | 0.40 mm        | 0.30 mm        |

## 6 CONCLUSION

We could establish the fabrication and the surface treatment techniques of non-axially symmetric squashed cell shape superconducting Nb crab cavities and the simplified co-axial Nb coupler for KEKB. Especially the hydro-forming method and the flow forming method are applicable to half cell and accuracy beam pipe.

## 7 REFERENCES

- [1] K.Hosoyama et al. Proc. of the 7<sup>th</sup> workshop on RF superconductivity p.671 (1995)
- [2] K.Hosoyama et al. Proc. of the 8<sup>th</sup> workshop on RF superconductivity p.547 (1997)
- [3] K.Saito et al. Proc. of the 4<sup>th</sup> workshop on RF superconductivity p.635 (1990)