



COMPANY PROFILE



MITSUBISHI SHIPBUILDING CO., LTD.
3-1, Minatomirai 3-chome, Nishi-ku, Yokohama, Kanagawa,
220-8401, Japan
Phone: 81-45-200-6611
<https://www.mhi.com/group/mhimsb/>



Creating the Future in the Sea Founded on Solid Technology

Mitsubishi Shipbuilding Co., Ltd. covers the maritime-related businesses of Mitsubishi Heavy Industries (MHI) Group. We help propel forward the development of the maritime industry both in Japan and around the world through conventional shipbuilding and marine engineering, based on our deep technological expertise in shipbuilding and by leveraging the wide range of technologies across MHI Group.

Throughout our long history in shipbuilding, we have helped develop the maritime industry, including the establishment of maritime laws, regulations and standards, while manufacturing a broad range of ships and maritime products. By making full use of the foundational technologies that we have accumulated over many years and the integration capabilities that bring them together, we accommodate the needs of a variety of customers by adhering to a customer-first philosophy and actively taking on new challenges.

We, Mitsubishi Shipbuilding, will create the future in the sea founded on solid technology.



Mission

We will create the future in the sea founded on solid technology.

Vision

We aim to address needs and challenges in the maritime industry by proactively keeping new challenges, creating values, and aiding sustainable development, all based on our deep shipbuilding expertise.

Value

We value "safety," "reliable quality" and "timely response" in accordance with the MHI Group Global Code of Conduct.

Mitsubishi Shipbuilding's Commitment to SDGs

We have established the "2050 Vision" to address the SDGs through each business and product.

2050 Vision 01

Creating a Safe and Secure Future for Society

Growing DX technology offerings and service businesses beyond the traditional borders of the shipbuilding industry.

Building a sustainable relationship between people and the ocean to realize a circular society where all can live in comfort and peace.



Digitalization of the Maritime Industry

Employing DX technology to create a safer and more efficient working environment for all involved in the maritime industry

Related Products

Navigation Assistance System,
Hybrid Electric Propulsion Vessel

Acceleration of Offshore Resource Development

Contributing to the safe development of offshore resources and environmental protection by proven technologies

Related Products

Marine Research Ship,
Cable Layers

Enhancement of User Experience on the Ocean

Enabling utilization of offshore space for enhanced passengers' experience

Related Products

Small Passenger Ship,
Car and Passenger Ferry

2050 Vision 02

Realizing Decarbonization of the Maritime Economy

Leading decarbonization of ships and accelerating offshore utilization of green energy and carbon capture.

Promoting harmony between people and the environment, and realize a sustainable and resilient decarbonized society through maritime business.



Decarbonization of Ships

Expanding the application of SOx scrubbers and LNG fuel, and working toward the adoption of electric propulsion and ammonia fuel in the future

Related Products

SOx Scrubber, Fuel Gas Supply System,
LNG-fueled ferry

Expansion of Renewable Energy Utilization

Driving growth in offshore wind farms and production of green fuels utilizing renewable energy

Related Products

Semi-submersible Floater
for Wind Turbines

Implementation of CCS/CCUS

Advancing CO₂ storage and utilization from captured industrial emissions

Related Products

Onboard CO₂ capture plant,
Liquefied CO₂ Carrier

Greetings from President & CEO



Mitsubishi Shipbuilding (MSB) is a company established in 2018 that succeeded to Mitsubishi Heavy Industries' (MHI's) shipbuilding business which was founded in 1884. Since we started our business under the authentic name of Mitsubishi Shipbuilding, we have been actively engaged in providing marine engineering and services while building and delivering of a wide variety of ships. And today, the global and Japanese maritime industry are faced with complex multi-solution problems such as populational, environmental, geopolitical, and technological subjects. It's time for us to brave these challenges.

MSB will make every effort to solve such problems through a new shipbuilding business model. Complex problems require complex solutions. Those problems are not so simple that single organization can solve. We are going to tackle the problem with global cooperation. We will move forward and grow together with our business partners.

We will develop cutting-edge technology, as a densely outfitted ship we build in practice and as a green technology to utilize LNG (liquefied natural gas), ammonia and LCO2 (liquefied carbon dioxide). We will also incorporate innovative method for development, engineering and construction of ships, and will lead the collaboration with business partners.

We will keep growing to achieve future success and take actions with responsibility.

Safety first is our motto in all cases. We pursue to create value through reliable quality and timely response and contribute to making the shipbuilding business even more attractive.

President & CEO
Shin Ueda

Organization

Mitsubishi Shipbuilding Co., Ltd.		Y	S	N
Planning & Administration Department		Y	S	N
Business Department		Y	S	
Procurement Department		Y	S	N
Shimonoseki Quality Assurance Department			S	
Nagasaki Quality Assurance Department		Y		N
Marine Engineering Center		Y	S	N
Strategic Planning & Operation Office		Y		
Engineering Business Department		Y		
Ship & Ocean Engineering Department		Y	S	N
Environmental Technology department		Y		N
Designing Department			S	N
Shipbuilding & Repair Department			S	N
Health, Safety & Environment Management Office			S	N

Y: YOKOHAMA
S: SHIMONOSEKI
N: NAGASAKI

Corporate Overview

Company Name: Mitsubishi Shipbuilding Co., Ltd
 Establishment: January 1, 2018
 Head Office: 3-1, Minatomirai 3-chome, Nishi-ku, Yokohama, Kanagawa, 220-8401, Japan
 President & CEO: Shin Ueda
 Business Operations: Ship engineering, design, manufacture and repair of ferries, cargo and passenger ships, RO/RO ships, special-purpose vessels, patrol vessels, etc.
 Capital: 3,000 million yen (MHI: 100%)
 Group Companies: MHI Marine Engineering, Ltd.
 MHI Shimonoseki Engineering Co., Ltd.

History

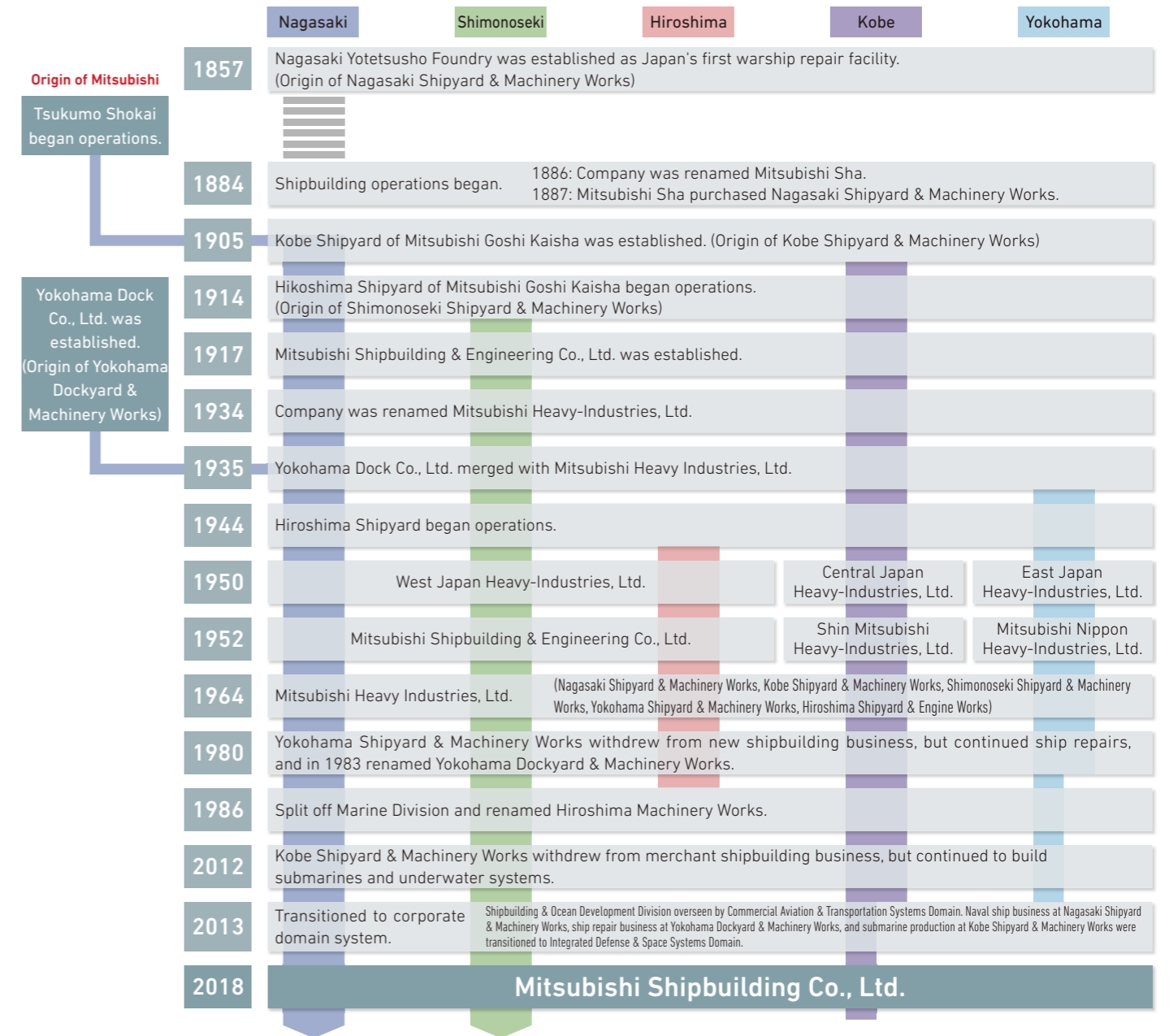

Locations

Yokohama (Head Office)

3-1, Minatomirai 3-chome, Nishi-ku, Yokohama, Kanagawa, 220-8401, Japan



Shimonoseki Site (Enoura Plant)

16-1, Hikoshima Enoura-cho 6-chome, Shimonoseki-shi, Yamaguchi, 750-8505, Japan



Nagasaki Site (Main Plant)

1-1, Akunoura-machi, Nagasaki-shi, Nagasaki, 850-8610, Japan

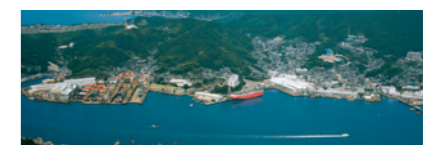

Nagasaki Site (Koyagi Plant)

180 Koyagi-machi, Nagasaki-shi, Nagasaki, 851-0310, Japan



Product Lineup

As the company that launched modern shipbuilding in Japan, MHI Group has always been at the forefront of shipbuilding and ocean development. Drawing on over a century of tradition and technological capabilities, the Group develops and builds an array of commercial ships and special-purpose vessels to meet a wide variety of needs. It is working to expand its engineering business in an effort to broaden its role on the world's seaways.



Commercial Ships

- Ferries & Cargo-Passenger Ships
- Car Carriers
- Cable Layers
- Patrol Ships

- RO/RO Ships
- Marine Resource Research ships
- Survey / Research / Training Ships
- Other Special Ships

Engineering Business

- Shipbuilding Engineering (LPG Carriers, Bulk Carriers etc.)
- Marine Solution Provider
- Environment- and Energy-related Technologies

Commercial Ships

Ferries & Cargo-Passenger Ships



SUNFLOWER KURENAI (LNG-fueled vessel) Ferry

Gross Tonnage	17,114 GT	Speed	22.5 knots
Length	199.9 m	Shipyard	Shimonoseki
Breadth	28.0 m		



HAMAYU Ferry

Gross Tonnage.....	15,515 GT	Speed	28.3 knots
Length	222.5 m	Shipyard	Nagasaki
Breadth.....	25.0 m		



KITAKAMI Ferry

Gross Tonnage	13,694 GT	Speed	21.5 knots
Length	192.5 m	Shipyard	Shimonoseki
Breadth	27.0 m		



SALVIA MARU Cargo-Passenger Ship

Gross Tonnage	6,099 GT	Speed	20.0 knots
Length	118.0 m	Shipyard	Shimonoseki
Breadth	17.0 m		



YURIYA Cargo-Passenger Ship

Gross Tonnage	273 GT	Speed	23.0 knots
Length	46.0 m	Shipyard	Shimonoseki
Breadth	8.0 m		

Commercial Ships

RO/RO Ships, Car Carriers, Marine Resource Research Ships, Survey/Research/Training Ships



FUJIKI RO/RO Ship

Gross Tonnage 15,986 GT Speed 23.0 knots
 Length 167.0 m Shipyard Shimanoeseki
 Breadth 30.2 m



TRANS FUTURE 11 Pure Car Carrier

Gross Tonnage 28,775 GT Speed 21.0 knots
 Length 165.0 m Shipyard Shimanoeseki
 Breadth 27.6 m



MARIMO RO/RO Ship

Gross Tonnage 11,229 GT Speed 23.0 knots
 Length 179.9 m Shipyard Shimanoeseki
 Breadth 27.0 m



HIMAWARI 8 RO/RO Ship

Gross Tonnage 10,626 GT Speed 23.0 knots
 Length 166.9 m Shipyard Shimanoeseki
 Breadth 27.0 m



HAKUREI Marine Resource Research Vessel

Gross Tonnage 6,283 GT Speed 15.5 knots
 Length 118.3 m Shipyard Shimanoeseki
 Breadth 19.0 m



KAIMEI Seabed Research Vessel

Gross Tonnage 5,747 GT Speed 12 knots
 Length 100.5 m Shipyard Shimanoeseki
 Breadth 20.5 m

Patrol Ships, Survey/Research/Training Ships, Cable Layers, Other Special Ships



ASAZUKI Patrol Vessel

Gross Tonnage 6,500GT Speed 25.5knots or more
 Length 150 m Shipyard Shimanoeseki
 Breadth 16.8 m



TENYO MARU Fisheries Training Vessel

Gross Tonnage 995 GT Speed 12 knots
 Length 64.67 m Shipyard Shimanoeseki
 Breadth 11.90 m



HAKUHO MARU Ocean Research Vessel

Gross Tonnage 3,991 GT Speed 16 knots
 Length 100.0 m Shipyard Shimanoeseki
 Breadth 16.2 m



TERESA MAGBANUA Multi-Role Response Vessel

Gross Tonnage 2,265 GT Speed 24knots
 Length 96.6 m Shipyard Shimanoeseki
 Breadth 11.5 m



SUBARU Cable Layer

Gross Tonnage 9,557 GT Speed 13.2 knots
 Length 123.33 m Shipyard Shimanoeseki
 Breadth 21.0 m



HAYAKAZE Fisheries Patrol Vessel

Gross Tonnage 56 GT Speed 35 knots or more
 Length 26.0 m Shipyard Shimanoeseki
 Breadth 5.4 m

Environmental and Energy Technologies

LNG Fuel Gas Supply System (LNG FGSS)

LNG Fuel Gas Supply System (FGSS) enables marine diesel engines to be fueled by LNG. Modularized FGSS, which minimizes shipyard's installation work, LNG fuel tanks and gas engineering services can be provided.

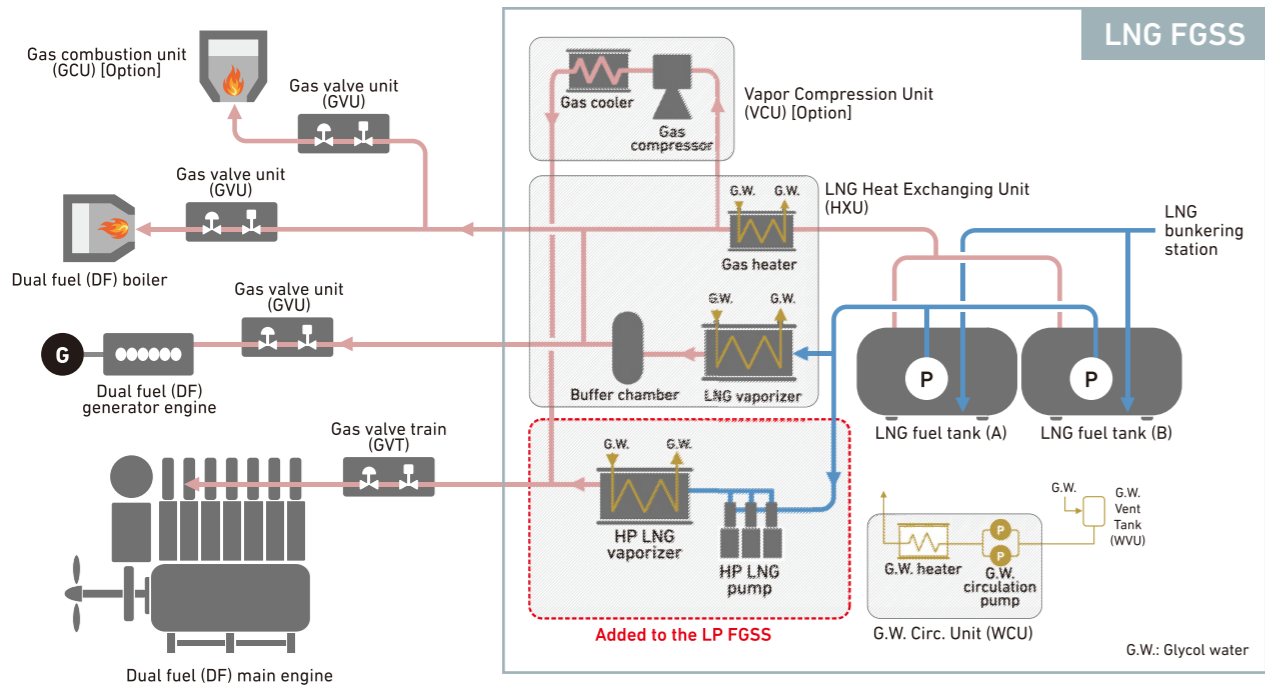

Please see the catalog for details.

S0x Scrubber System DIA-S0x®

DIA-S0x® is S0x scrubber system specially designed over meticulous study and risk assessment to achieve high reliability and safety. It is also compatible to conventional machinery systems. For easier, faster and safer installation on ships, engineering services can be provided.

● DIA-S0x®C-series

Cylindrical type for small output engines.
Main Engine Output 5-30 MW

● DIA-S0x®R-series

Rectangular type for large output engines.
Main Engine Output 30-75 MW



Please see the catalog for details.

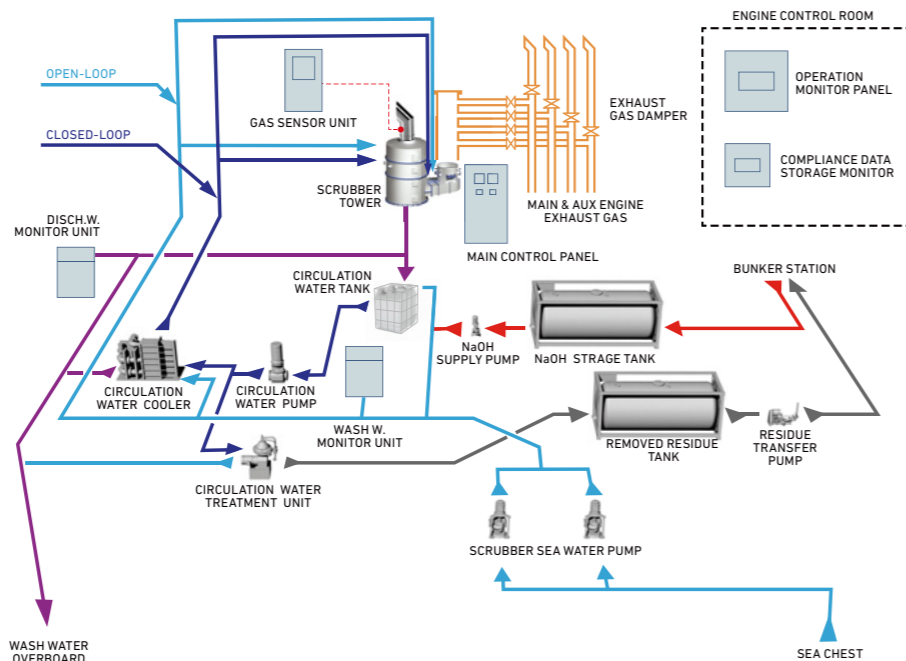

Design and Engineering Services

Utilizing advanced CFD analysis and vast model test records, energy efficient hull form will be developed and provided to our customer shipyards. Additionally, variety of design and analysis services, propeller and energy-saving devices can be provided.

- Hull form development
- Various model testing menus
- Propeller
- Energy-saving devices (Reaction Fin)
- Concept / basic / detail design
- Structural / vibration / ventilation analysis
- 3D Modeling
- Power Prediction & Lines Selection (MiPoLin) system using the huge database of model test results.
- Sales of Mitsubishi Advanced Total Engineering system of Ships (MATES) and 3D-Viewers (HullViewer/FitViewer)

Other than above, flexible solutions can be provided upon requests.

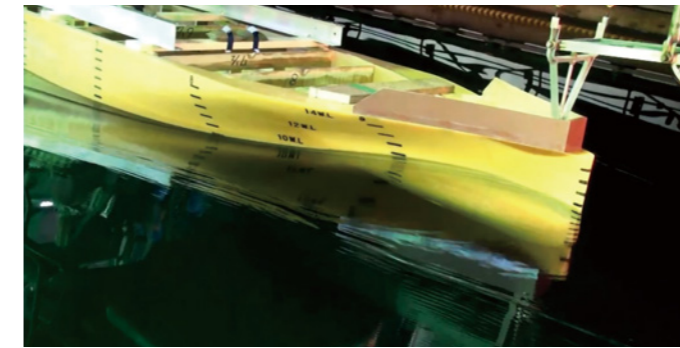

Wave Shape from Model Test

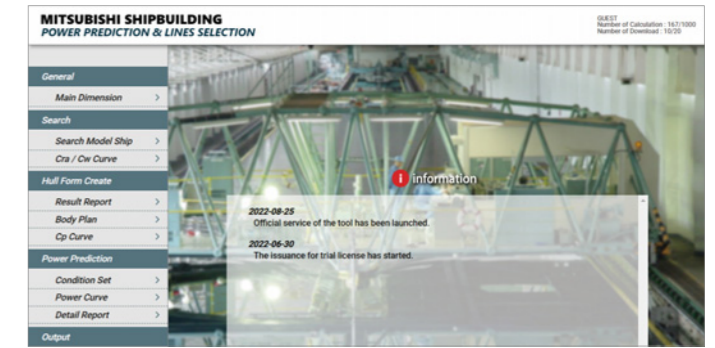

Power Prediction & Lines Selection (MiPoLin)



Shallow Water 30,000m³ LNG Carrier Concept



MATES® Machinery Room 3D Design

Navigation Assistance System

Through the partnership with Marindows Inc., maritime start-up focused on DX, Mitsubishi Shipbuilding is delivering safety and security to the domestic shipping industry. We are tackling agendas such as improving the working environment for seafarers and preventing accidents at sea.

Digitalization of ship's system

- Portable navigation assistance system "Navico" (Collaboration with Marindows Inc.)
- Based on electrical sea-chart "new pec", GPS position of own-ship & AIS information of other ships are provided.
- Route planning, route tracking, grounding alert and collision alert and collision avoidance assistance.
- Audio input/output
- Plans to be connected to cloud system and other on-board devices such as on-board dash cam for further enhanced functions.

