

# VRF multi-system Air Conditioners

# **KXZ<sup>2</sup>** **PLUS**

Climate & Energy  
Solution for Cooling

# 2026



**New KXZ2 PLUS series**  
Cooling system Air-Conditioners



# New Climate & Energy Solution

The new Mitsubishi Heavy Industries KXZ VRF series delivers high performance in cooling and heating for all commercial applications. The KXZ series provides the highest level of design flexibility, efficiency as well as operational functions. This brochure highlights the key benefits and new and improved functions of our latest VRF technology.



## Line-Up



# KXZ<sup>2</sup> PLUS

## CONTENTS

<b>Introduction</b> .....	2	<b>Ventilation</b> .....	120
<b>Outdoor units</b> .....	20	Fresh Air Ventilation and Heat Exchange unit .....	120
KXZ2 PLUS series .....	30	Fresh Air DX Assembly .....	122
KXZ2 series .....	40	<b>Electronic Expansion Valve Kit</b> .....	124
Corrosion Protection Treatment series .....	54	<b>Control Systems</b> .....	126
KXZ series Water cooled series .....	56	<b>Building Management Systems</b> .....	134
KX6 series High Head models .....	58	<b>Support tool</b> .....	135
Micro KXZ series .....	62		
Micro KX .....	66		
KXZ Lite .....	70		
<b>Indoor units</b> .....	76		
Ceiling Cassette .....	80		
Duct Connected .....	94		
Wall Mounted .....	107		
Ceiling Suspended .....	110		
Floor Standing .....	112		
Outdoor Air Processing unit .....	116		



# VRF MULTI SYSTEM

## KXZ system is the best air conditioning solution for "Sophisticated" buildings

KXZ VRF series delivers high cooling/heating performance for all commercial applications.

We offer a lineup of both the reversible (cooling/heating) heat pump (KXZ2 series) and the cooling only systems (KXZ2 PLUS series), which can accommodate a wide range of environments.

## Heat pump systems

The heat pump systems operate with 2 inter-connecting pipes and are commonly referred to as a '2-pipe systems'.

The KXZ2 series provide either a heating or cooling operation, and the KXZ2 PLUS series provide a cooling operation to all indoor units. Both are suitable for a wide range of applications from an apartment or villa to an entire multi-story building, especially when there are significant open plan areas to be controlled.

The range starts with a 11.2kW cooling capacity, up to 20HP with 56.0kW cooling capacity. Outdoor units can also be "twinned" or "tripled" providing up to 60HP/168.0kW on a single system. The range has a total piping length of 1000m (KXZ2), and the furthest indoor unit can be connected up to 160m (KXZ2) from the outdoor unit.

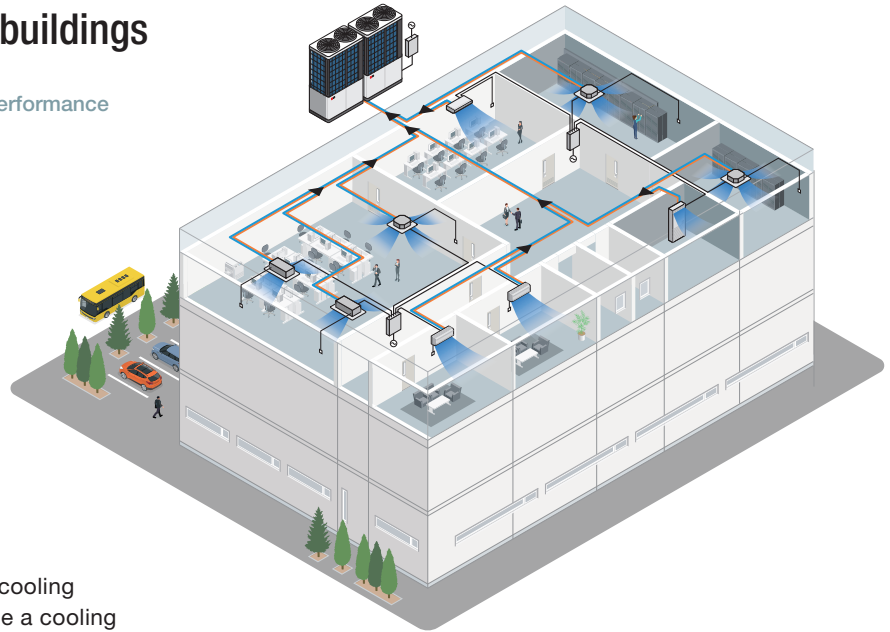

**KXZ<sup>2</sup>**  
**PLUS**



**KXZ<sup>2</sup>**



## Environmental

Mitsubishi Heavy Industries, Ltd. (MHI), are unwaveringly dedicated to facing the challenges of the future.

MHI are dedicated to supporting global sustainability by offering the most energy efficient air-conditioning systems. Through our in-depth research and development, we are able to incorporate new technologies within our units to maximise their energy efficiency and significantly reduce carbon emissions.

### Environmental Impact.

MHI recognises the increasing importance of reducing carbon emissions as this is becoming a priority when selecting air and water distribution systems. Furthermore new technologies are constantly being developed to help meet heating and cooling requirements as well as environmental objectives.

The future of our planet rests in the sustained evolution of humankind while caring, with love and responsibility, for all life forms that inhabit it. Therefore MHI will continue to develop new technologies and products and will remain competitive in the market to achieve a sustainable future.

# Development History of the MHI's VRF KX Series

MHI's VRF systems have a long history dating back to 1984. For the global market, the first lineup, the KX Series, was introduced in 1994. The upward flow type has continuously evolved, and now the KXZ2 PLUS Series represents the latest stage of this evolution.

1984 FDC-1HP

for the Japanese market

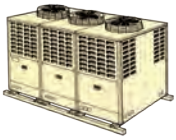

1994 FDC-1HKXES

HyperMulti  
KX



1997 FDC-1HKXE2

HyperMulti  
KX



2004 FDC-HKXE4

HyperMulti  
KX



2008 FDC-KXE6

HyperMulti  
KX



Development History

2014 FDC-KXZE1

KXZ  
series



2021 FDC-KXZE2

KXZ 2



2025 FDC-CKXZA2S

KXZ 2  
PLUS



## Specific cases of VRF system installation from Mitsubishi Heavy Industries Thermal Systems

Case study : **Education**



Case study : **Hotel and Leisure**



We're excited to have provided Crossways Academy in Lewisham with our VRF system, making the school a cooler and more comfortable place for learning.

Maintaining comfortable temperatures in rooms frequented by large groups of students is crucial, and it must be done economically. Factors like simultaneous entries and exits of students, fluctuations in heat load due to IT equipment usage, and the operation of electric blinds to control glare all play significant roles in this endeavor. The VRF KX system from Mitsubishi Heavy Industries Thermal Systems offers an ideal solution for your needs. Designed with a focus on natural ventilation, the building utilizes electronically operated windows. The air conditioning system is seamlessly integrated with this control system, ensuring it shuts down when windows are opened. Mitsubishi Heavy Industries Thermal Systems KX is specifically suitable for various retrofit applications, making it a perfect fit for your requirements.

Mitsubishi Heavy Industries (MHI) Thermal Systems' VRF heat recovery systems, part of the KX range, are perfectly suited to meet the rigorous requirements of luxury hotels and "airport-style" bus stations. These systems feature advanced inverter technology, which intelligently adjusts compressor output to precisely match the cooling or heating demands of indoor units. This ensures optimal comfort and energy efficiency in demanding environments. By opting for our adaptable heating and cooling system, you're not just saving energy, but also gaining precise control over room temperatures. Our system empowers you to adjust heating and cooling levels in different areas according to specific needs.

For instance, in sunnier, south-facing rooms where temperatures tend to rise, you can effortlessly increase the heat to maintain comfort. Meanwhile, in cooler, shadier areas of your building, our system efficiently provides energy for heating, ensuring consistent comfort throughout.

With this flexibility, you can optimize energy usage based on varying conditions, enhancing both comfort and energy efficiency in your space.

# The advanced **cooling only** KXZ series

# KXZ 2 PLUS



The KXZ2 PLUS series enhances both reliability and flexibility through an expanded operational range and increased external static pressure, achieved by optimizing our KXZ2 series.

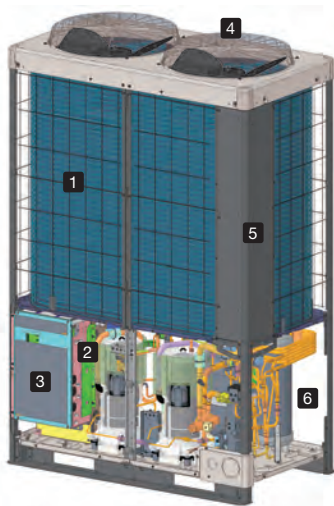

- 1 Highly efficient Heat exchanger
- 2 Optimised duct shape
- 3 Inverter control
- 4 DC Fan Motor
- 5 Rounded design
- 6 Compressor

The compressor has improved the units efficiency by innovating the thrust plate. Resulting a reduced friction loss, and increased reliability.

Cooling use in high ambient temperature

## Wide range operation

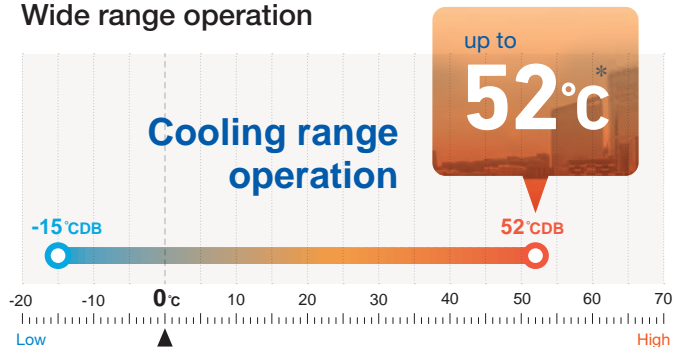

\* With limitation to piping length and height difference between indoor and outdoor units.

## Extended external static pressure

Max:  
50 Pa to 85 Pa

Flexibility to meet installation location needs.

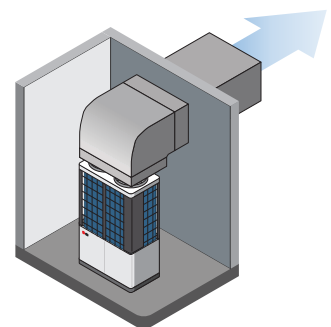

## Indoor unit capacity connection

Increased number of connectable units and max capacity connection

(compared to KXZE1)

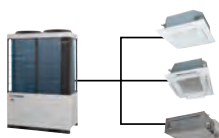

HP	10	12	14	16	17	18	20	22	24	26	28	30	32	34
Numbers	37	44	53	60	50	53	59	65	71	78	80			
IU Capacity connection	50 - 200%*						50 - 160%*							

HP	36	38	40	42	44	46	48	50	52	54	56	58	60
Numbers	80												
IU Capacity connection	50 - 130%*												

\* When connecting the indoor unit type FDK, FDFL, FDFU or FDFW series, limit the connectable capacity not higher than 130%.

## Increased efficiencies

### Cooling mode Comparison of EER

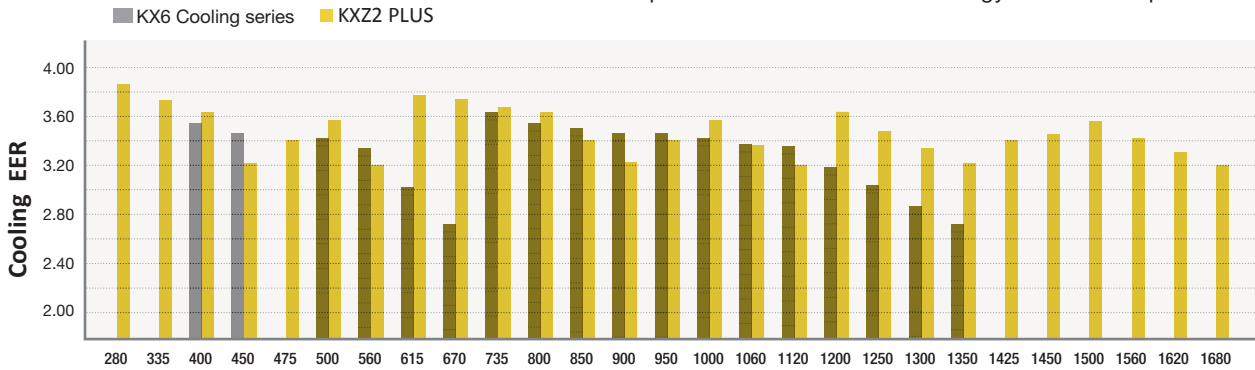

Our **KXZ2 PLUS** series provide high performance and excellent energy savings across all ranges. This is achieved by the optimized heat exchangers with the increased capacities and the advanced energy efficient compressor.

## Long Pipe length

Total length :  
**1,000m**

**Furthest indoor unit:**  
Actual length: **160m**  
Equivalent length: **185m**

The maximum height difference between indoor units is a maximum of 30m, and the maximum height difference between the outdoor unit and indoor unit is 90m.

For with few limitations, contributes to system design flexibility.

\* The difference between the longest and the shortest indoor unit piping from the first branch must be within 40m. (MAX85m)

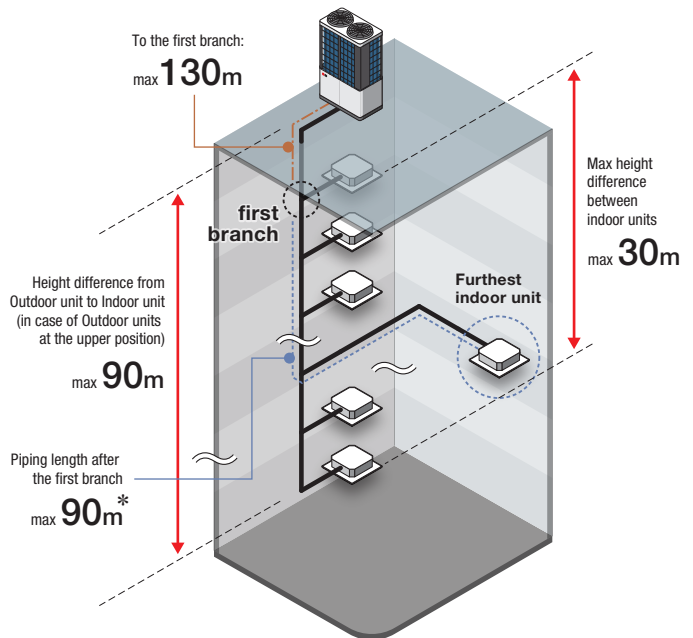

## Variable Temperature and Capacity Control

# VTCC

Energy Savings \*  
**34%**

VTCC adjusts the target pressure of the refrigerant cycle in the outdoor unit automatically according to the demand of the indoor units in partial load conditions. These smooth adjustments ensure optimal usage of the indoor units as well as maximised energy savings. Ultimately this also increases comfort for the user.

### Normal operation

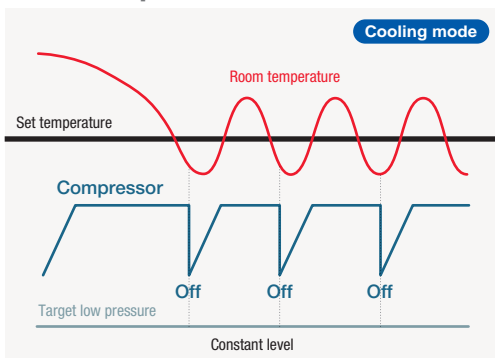

### Energy saving operation

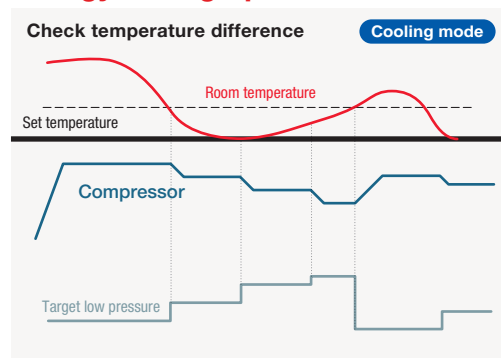

\* 34% energy savings are based on comparison with a KXZ standard model with VTCC vs. a KXZ standard model both under partial local condition.

# Next Generation Refrigerant R32

New indoor units and outdoor units line up are available for R32 refrigerant



FDT



FDTC



FDK

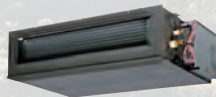

FDU



FDUM



FDUT

## F-GAS REGULATION (EU) No 517/2014

Introduced in January 2015 to regulate the use of Fluorinated Greenhouse Gases (F-Gases)

The Hydrofluorocarbons (HFCs) are F-Gases used in the HVACR sector (Heating, Ventilation, Air Conditioning and Refrigeration)

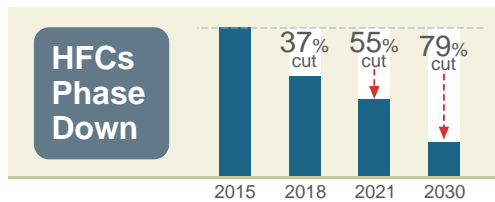

### OBJECTIVE

To protect the environment by reducing the F-Gases emissions

### IMPACT ON HFCs(in EU)

HFCs Phase Down

HFCs Ban

### SOLUTIONS

- Use lower GWP\* refrigerants in new equipment
- Use high-efficiency equipment with less refrigerant charge
- Check refrigerant leaks regularly

\* GWP is the Global Warming Potential of a refrigerant, representing how much heat an F-Gas traps in the atmosphere

### HFCs Ban

2020

**GWP ≥ 150**  
Portable room air conditioner

**GWP ≥ 2500**  
Stationary refrigeration\*<sup>1</sup>  
(except < -50°C)

**GWP ≥ 2500**  
Commercial hermetically sealed refrigerators, freezers

2022

**GWP ≥ 150**  
Commercial multipack centralised refrigeration

**GWP ≥ 150**  
Commercial hermetically sealed refrigerators, freezers

2025

**GWP ≥ 750**  
Single Split Fixed Air Conditioning < 3kg HFC

\*1 Stationary refrigeration equipment, that contains or relies its functions upon, HFCs with GWP of 2500 or more except equipment intended for application designed to cool products to temperatures below -50°C application



LOWER GWP + LESS REFRIGERANT CHARGE = LOWER HFCs EMISSIONS

# R32 - A Low GWP Refrigerant

- A single component, easy to handle refrigerant
- Known as a component of the blend R410A(50% R32, 50% R125)
- Already used in Air Conditioning systems worldwide
- Zero Ozone Depletion
- Superior Energy Efficiency vs. R410A
- Reduced refrigerant charge vs. R410A
- Easy to recycle

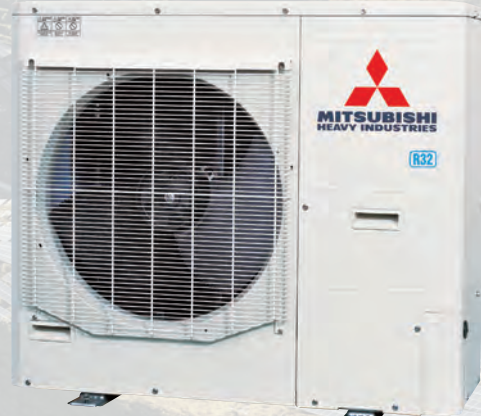

**Micro KXZ** Heat pump systems  
4, 5, 6HP (11.2kW – 15.5kW)

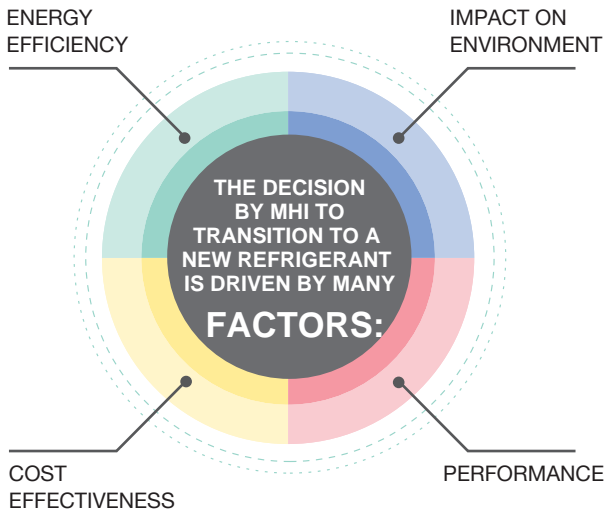

## Low Global Warming Potential

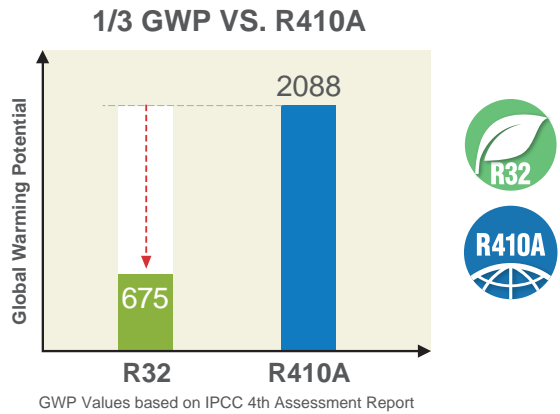

## Improved Energy Efficiency

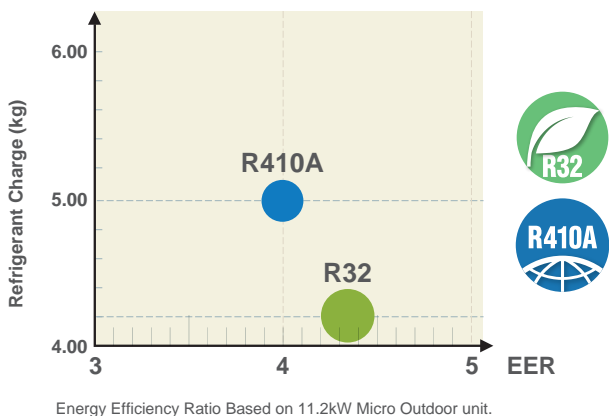

## Reduced Refrigerant Charge

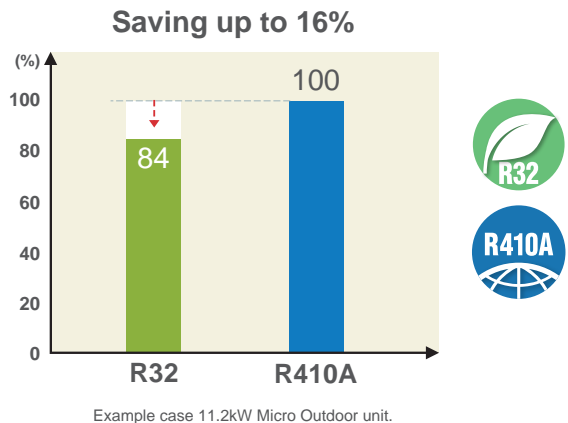

# FDT colour variation

Now available in shadow black

Blend in,  
or stand out.



Shadow black



Fine snow white



## Draft Prevention Panel (Option)

Keep maximum comfort with minimal draft : FDT & FDTC control flaps with more flexibility.

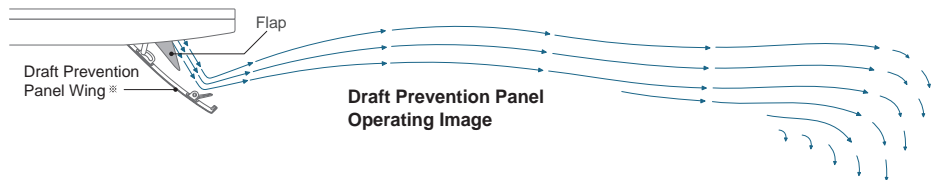
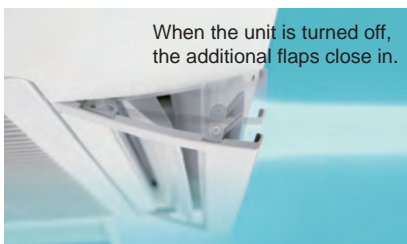

Each of the 4 flaps can be controlled individually at each operation mode. They change air flow direction and prevent drafts occurring. This function also provides flexible control for air flow direction. User can position Draft Prevention Panel panels by using only the remote controller (RC-EX3D, Wireless kit).

- It can also prevent user from being directly blown by hot drafts in heating mode.



Draft Prevention Panel off

Draft Prevention Panel working\*

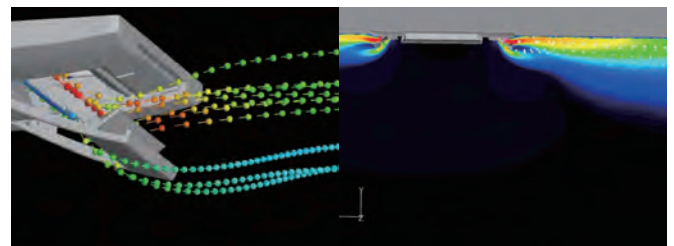
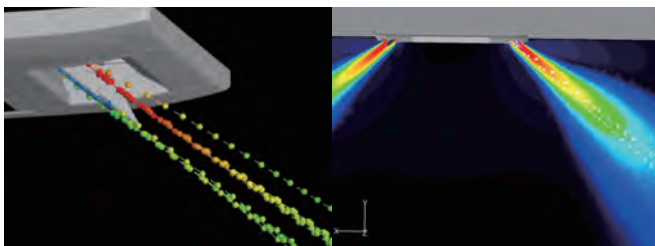

Draft Prevention Panel provides a comfortable airflow without any draft feeling. Whether cooling or heating a room, the remote control can be used to instantly suppress any warm or cool drafts. This accurately assists how air flow is directed out of the indoor unit.

\* Image is for illustration purposes

# FDTC - Compact Ceiling Cassette with an European design



A' Design Award and Competition is the World's largest, most prestigious and influential design accolade, the highest achievement in design. A' Design Award Winner Logo, symbolizes exceptional design excellence in products, projects and services.



## Ceiling Cassette Compact FDTC

- More comfort and Higher energy savings
- European Design
- Lower noise

### Thin Panel

FDTC thin panel fit within 10mm from the ceiling.

### Unique Grille Design

Honeycomb grille

### Draft Prevention Panel (Option)

Please refer to page 10



### Motion Sensor (Option)

Please refer to page 12-13

### Big Louver

Improved distribution

• It is available to set draft prevention panel and motion sensor as well as FDT.

## Compact Design

□700mm → □620mm

The weight is 14kg

Height of thin panel and main body is 248mm allowing adequate spacing for installation.

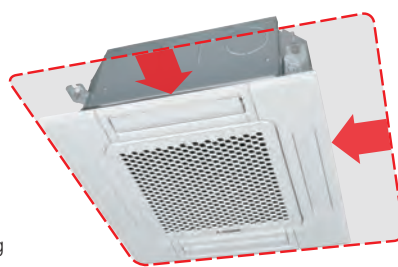

Integrated ceiling system design 600x600



## Quieter operation

Adopting turbo fan and improving heat exchanger enables noise reduction. (Sound pressure level in the Lo mode.)

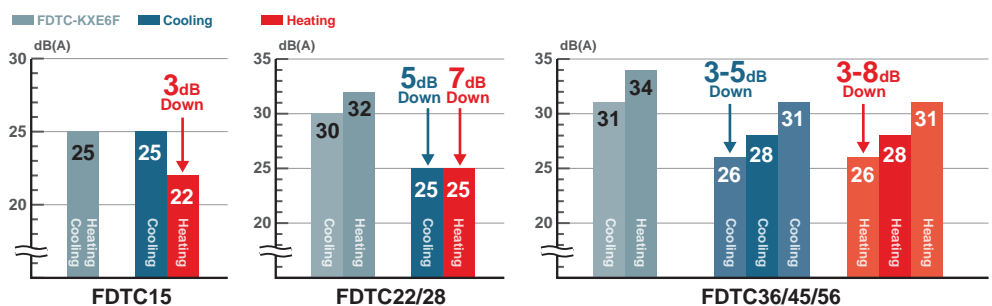

## **Motion sensor** (Option)

Energy saving operation by detecting human movement

Optional for the following models



FDT



FDTC



FDTW



FDTS



FDU



FDUM



FDUT



FDE



FDK



FDU-F



FDTQ



FDFL



FDFU

# 3 Step Control



## 1 Power Control

Motion sensor (option) detects human activity. Energy saving control is achieved by shifting set temperature according to detected amount of activity.

## 2 Stand by

Unit will go on stand-by mode when no activity is detected. When the motion sensor detects activity again, the unit will automatically re-start operation.

## 3 Auto Off

Unit will go off automatically when no activity is detected for 12 hours.

Low human activity (in cooling)



High human activity (in cooling)



Absence for 1 hour



12 hours absence

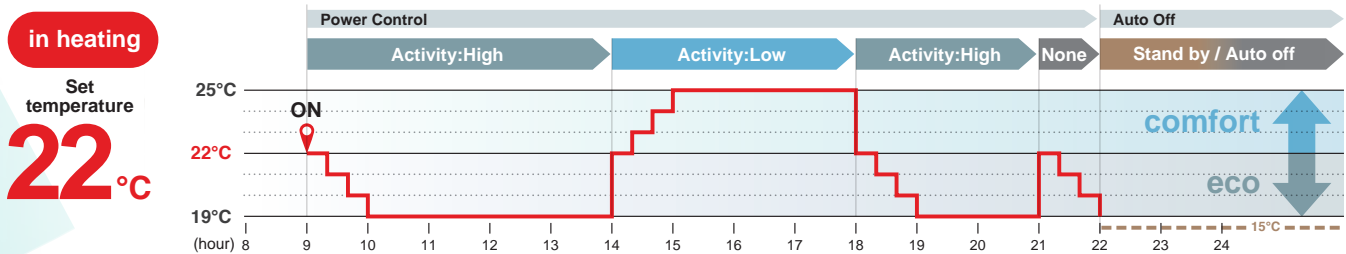
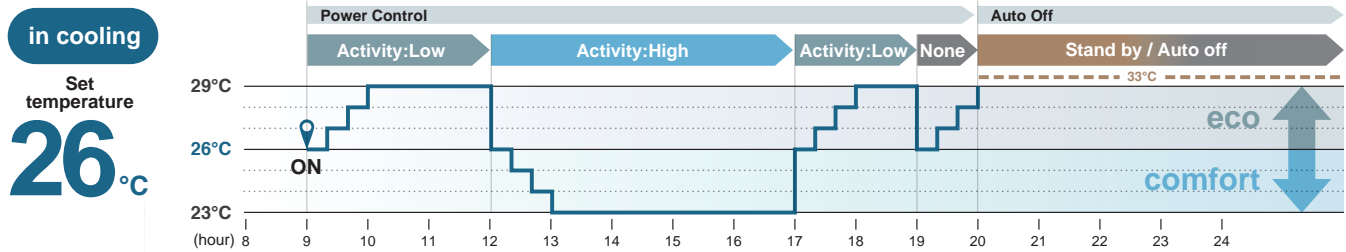

## Operation mode and Control of Motion sensor

		Operation mode					
		Auto	Cool	Heat	Dry	Fan	
Power Control *1	eco operation						
	Human activity	Low	Cooling +3°C Heating +3°C	+3°C	+3°C	-	-
		High	Cooling -3°C Heating -3°C	-3°C	-3°C	-	-
None	Cooling +3°C Heating -3°C	+3°C	-3°C	-	-		
Auto Off *2		●	●	●	●	●	

\*1 Set temperature is revised maximum ± 3°C at Cooling/Heating mode by detecting heat volume movement.

\*2 Absence for 1 hour ⇒ Operation stops ("Stand-by") 12 hours absence ⇒ Operation stops completely.

# Remote Control

Simple use with advanced settings REMOTE CONTROL

## RC-EX3D

Intuitive touch controller with Liquid Crystal Display

### Function Switch

The function switch allows you to select and set two functions of your choice among the seven available functions shown. These functions can be used by simply pressing the button after they are set, allowing you to use your preferable functions immediately.



#### 1. Draft prevention ON/OFF



Anti draft can be turned ON/OFF with a single tap of the button.

#### 2. High Power Mode



High Power Mode achieve excessive cooling / heating capacity in 15 minutes to quickly adjust the room temperature to a comfortable level.

#### 3. Energy Saving Mode



Temperature is set to be optimized to save energy without losing comfort.

#### 4. Quiet Mode



Outdoor unit starts to operate quietly by activating this mode. The time of this mode can be set in conjunction with Indoor Silent Timer.

#### 5. Home Leave Mode



Home leave mode maintains the room temperature at a moderate level.

#### 6. Favourite Mode



Operation mode, set temperature, fan speed and air flow direction will automatically be adjusted to the programmed favourite setting.

#### 7. Filter Sign



Announces the due time for cleaning the air filter.

### Favourite Mode

Operation mode, set temperature, fan speed and air flow direction are memorized and allocated to two buttons that can be operated by one touch.

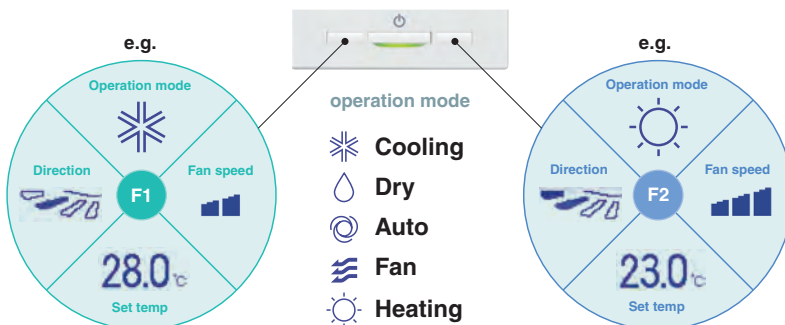

### Adjustable Brightness of the Operation Lamp

The brightness of the operation lamp behind Run/Stop switch can be adjusted by 10 stages.

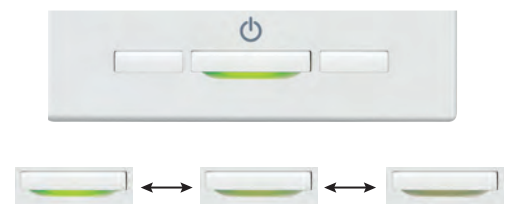

## Draft Prevention Setting (only for FDT•FDTC series)

User can enable/disable the motion of Draft prevention panel for each blow outlet for each operation mode. This function can be set while operating.

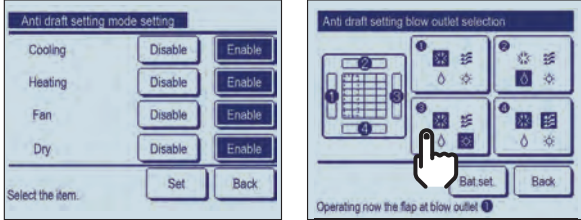

## Easy Adjustment of the Air Flow

User can visually confirm and set the direction of flaps using the visual display on the remote controller.

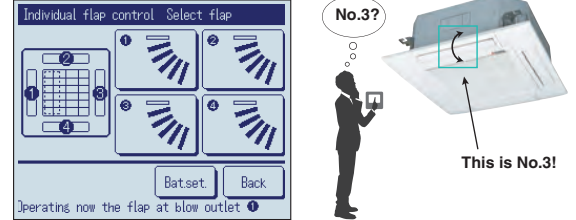

## Motion Sensor Control

Presence of humans and activity are detected by a motion sensor to perform various controls.

### 1 Select Enable / Disable Motion sensor control



Enable/Disable

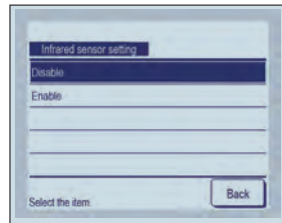

Select **Enable**/**Disable** for the motion sensor of the indoor unit connected to the R/C.

### 2 Select Enable / Disable per control

- Power control
- Auto-off

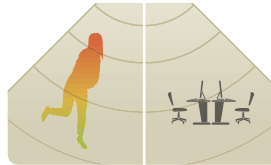

Enable/Disable

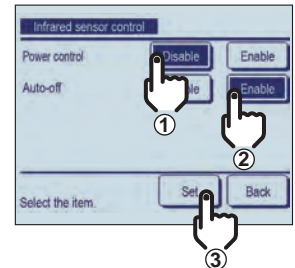

## Backup Control

Control restricted to two indoor units (two groups)



### Fault backup control

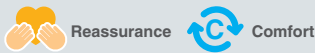

#### Keep back up all the time!

If one of the two indoor units malfunctions and stops its operation, the other starts backup operation so that users' comfort will not be compromised.

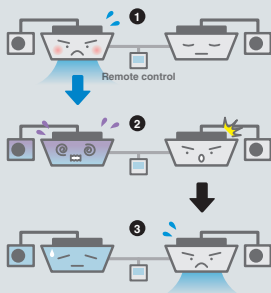

### Capacity backup control



#### Maintains users' comfort!

When the control system detects either of its two units operating with overload, the other unit cover the capacity.

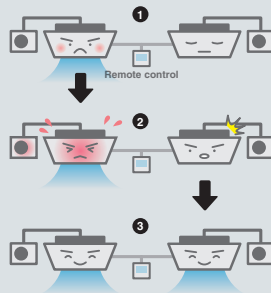

### Rotational operation control



#### Energy saving and longer life!

By operating two indoor units alternately, their chronological changes are equalized. (The alternate operation cycle can be specified in a range from 1 to 999 hours in increments of 1 hours.)

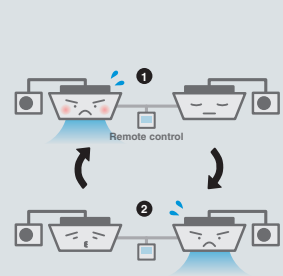

New

# Stylish Remote Control

## 2025 Design Award



reddot winner 2025

The RC-ES1 Series has been honored with the prestigious Red Dot Design Award 2025 in the Product Design Category.



The RC-ES1 Series has been honored with the prestigious Gold A' Design Award in the Repair, Restoration, and Maintenance Products Design Category.



## RC-ES1

- Stylish and sophisticated design
- Compact size (86×86mm)
- Remote control with Bluetooth® wireless technology
- Compatible with indoor units supporting the RC-EX3D remote controller.



## Optimized User Interface



The functions available on the remote have been minimized to focus on users' core needs, simplifying operation and avoiding overly complex settings. A wide range of functions, including service settings, remains accessible through the app.



You can control the air-conditioner by installing App on your smart phone



Search for "M-Air PRO" from the Google Play™ store for Android™ and App Store for iPhone.

Please check the app stores for the latest supported OS version information. App Store and iPhone are registered trademarks of Apple Inc. Google Play and the Google Play logo are trademarks of Google LLC.

## Wireless connection

- Remote control with Bluetooth® wireless technology
- Easy set-up of indoor units
- Notifications of abnormal conditions or operational data from the remote control will be sent to your smartphone.



## Information screen

By looking at the information screen, you can check the current operating conditions at a glance.



## Central management by smart phone

You can select and change the settings of multiple rooms with only one action on your smartphone.\*

Easy setup and management of up to 20 units via smartphone and tablets, up to 10 settings could be saved in the app.

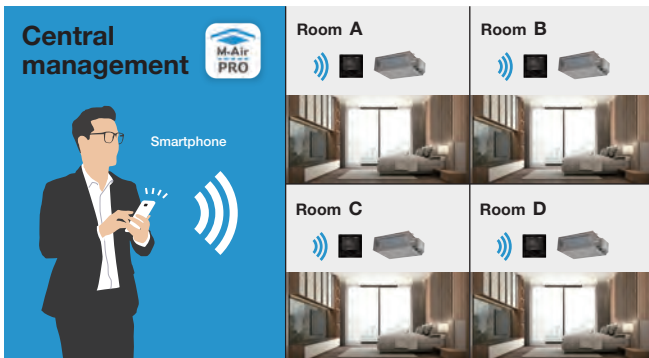

## Easy installation with the new casing structure

The casing is separated into the lower and the upper case.

By inserting the upper case into the lower case embedded to the wall, the remote could be easily installed.

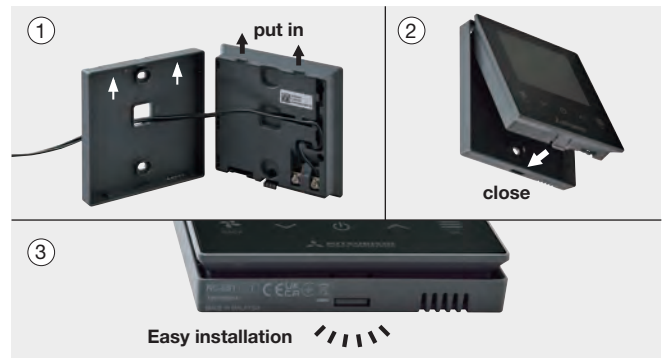

\*The function would be available when the smartphone is connected to the remote control with Bluetooth® wireless technology.

## Easy to instinctively operate with simplified icons

Operation settings	Common settings	Display & sound settings
<p><b>MODE</b> <b>Operation mode</b> Heating / Cooling / Fan / Dry / Auto</p> <p><b>High power</b> ON / OFF</p> <p><b>Ventilation</b> ON / OFF</p> <p><b>Timer</b> Set ON / OFF timer by hour Set ON / OFF timer by clock</p> <p><b>Air direction</b> Upper / lower flap, Flap direction</p>	<p><b>Bluetooth</b> ON / OFF</p> <p><b>Pairing mode</b> Make a new Bluetooth pairing</p> <p><b>App QR code</b> QR code for the app</p>	<p><b>Brightness</b> 1-10</p> <p><b>Lighting time</b> 1-10</p> <p><b>Operation sound</b> Sound On / Sound Off</p>
Information screen		
<p><b>Temporary stop</b></p> <p><b>Thermo-off</b></p> <p><b>Fan operation</b></p> <p><b>Cooling test run</b></p> <p><b>Static pressure adjustment</b></p> <p><b>Dew drop prevention control</b></p> <p><b>Home leave operation</b></p>	<p><b>High power operation</b></p> <p><b>Eco operation</b></p> <p><b>Set temp. shift</b></p> <p><b>Warm up operation</b></p> <p><b>Heating preparation</b></p> <p><b>Defrost operation</b></p> <p><b>Outdoor silent operation</b></p>	<p><b>Motion sensor control</b></p> <p><b>Anti draft control</b></p> <p><b>Demand control</b></p> <p><b>Filter cleaning time</b></p> <p><b>Back-up control in operation</b></p> <p><b>Fault back-up control in operation</b></p> <p><b>Periodical check indication</b></p>
		<p><b>ON timer setting</b></p> <p><b>OFF timer setting</b></p> <p><b>Weekly timer setting</b></p> <p><b>Sleep timer setting</b></p>

The Bluetooth® word mark and logos are registered trademarks owned by Bluetooth SIG, Inc. and any use of such marks by MITSUBISHI HEAVY INDUSTRIES THERMAL SYSTEMS, LTD. is under license.

Other trademarks and trade names are those of their respective owners.

"QR Code" is a registered trademark of DENSO WAVE INCORPORATED.

# Serviceability & workability (Indoor unit)

## Easy and quick installation and maintenance



**Quick positioning!**

### Indoor unit is easily positioned and installed

<p><b>1</b> Adjustable easier positioning of unit by new slits <span style="float: right;">FDT</span></p>	<p><b>2</b> New slit in panel allows easier installation on site <span style="float: right;">FDT FDTC</span></p>
<p>New shape of slit is suitable to install the unit with more flexibility, compatible with many kinds of suspending bolt pitch on site. Any rectangular or squared pitch of suspending bolts are available with this slit.</p>	<p>Flexible positioning is available, which helps adjusting the direction of panel accordingly to lines or pattern on the ceiling.</p> <p>4 long slits are available.</p>

### Quick installation and maintenance

<p><b>1</b> Easy access to component part for easy maintenance <span style="float: right;">FDT</span></p> <p><b>1</b> The control box and bell mouth can be removed together. <span style="margin-left: 150px;"><b>2</b> Easy access to impeller and fan motor.</span></p>	<p><b>2</b> New shape of path of wiring <span style="float: right;">FDT</span></p> <p>New shape of path gives easy wiring work for installation.</p>
<p><b>3</b> No need to remove screws to open the controller cover <span style="float: right;">FDT</span></p> <p>It is possible to loose and slide open the cover without removing the screws. This prevents the cover from falling and causing damage on site.</p>	<p><b>4</b> More safe installation by stopper of washer <span style="float: right;">FDT FDTC</span></p> <p>When unit is installed with hook between washers, this stopper helps to install the unit safely, without adjusting washer.</p> <p>Separate the provisional washer securing material. Washer on the upper side.</p>

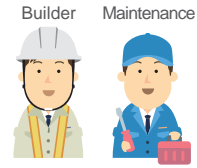

**For smooth and easy working**

## Easy installation and maintenance

**1** Easy and flexible hook to remove the filter FDT  
FDTC

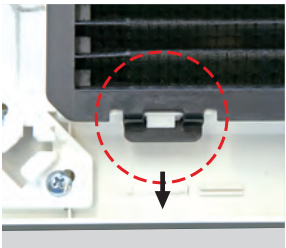

Hook of soft material helps to remove the filter without dust spreading.



Press the filter tab to the outside and remove the filter.

**2** Securely fix the corner lid by strap FDT

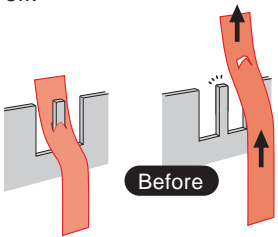
The direction of the strap hook part has been changed from longitudinal to lateral. Furthermore, a barb has been added to the hook pin to prevent the strap from coming off.





Easy to hook but not easy to loose

**3** Drain-up-lift increases up to 850 mm FDT  
FDTC

The drain can be lifted up to 850 mm from the ceiling surface.

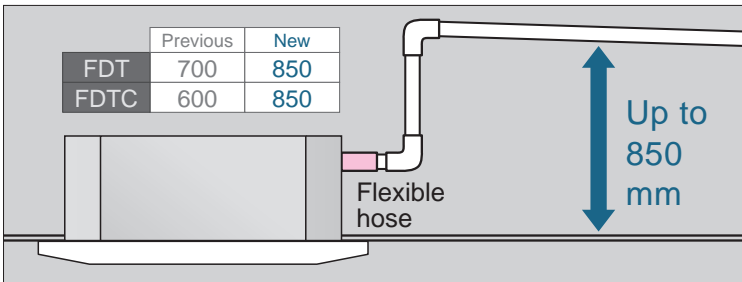
	Previous	New
FDT	700	850
FDTC	600	850



Up to 850 mm

**4** New port to check drain water flow FDT

A water supply port has been provided in the piping lid for easier testing of the drain water flow. (The port is usually sealed with a rubber cap.)

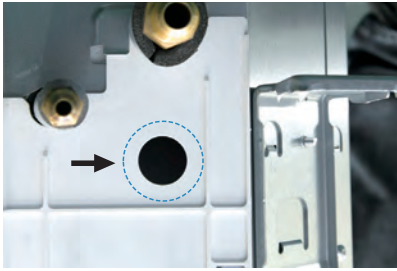

**5** Re-use of packages during construction work FDT  
FDTC

Package material (carton) helps to protect the unit from unexpected welding spatter or dust on the new unit.

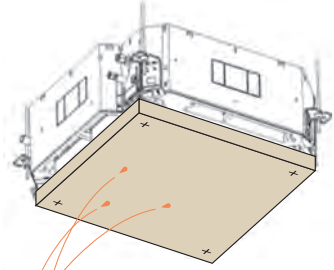

Spatter

**6** More flexible outlet for ducting FDT  
FDTC



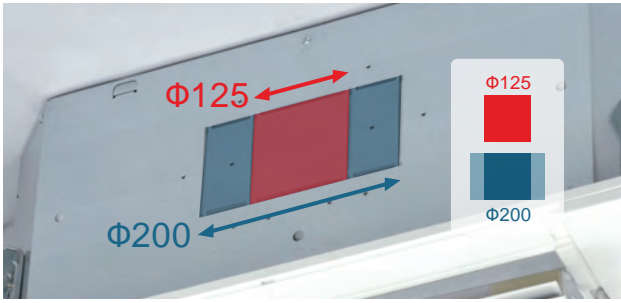





















Both  $\Phi 125$  and  $\Phi 200$  (oval shaped) are available.



# KXZ series product Line up

## Outdoor units



















Capacity Range	4HP	5HP	6HP	8HP	10HP	12HP	14HP	16HP	17HP	18HP	20HP	22HP	24HP
Model Code : kW	11.2	14.0	15.5	22.4	28.0	33.5	40.0	45.0	47.5	50.0	56.0	61.5	67.0
BTU / h	38,200	47,800	52,900	76,400	95,500	114,300	136,500	153,500	162,100	170,600	191,100	209,800	228,600
<b>KXZ2 PLUS</b> <b>Standard Cooling only</b> <b>New!</b> <ul style="list-style-type: none"> <li>Flexible design</li> <li>Wide range of operation (Up to 52°C)</li> <li>Extended external static pressure (Up to 85Pa)</li> <li>VTCC</li> </ul> 					 FDC280-335			 FDC400 - 560			 FDC615-670		
<b>KXZ2 PLUS</b> <b>Hi-COP combination Cooling only</b> <b>New!</b> <ul style="list-style-type: none"> <li>Higher energy savings</li> <li>Flexible design</li> <li>VTCC</li> </ul> 											 FDC560		
<b>KXZ2</b> <b>Standard</b> <ul style="list-style-type: none"> <li>Flexible design</li> <li>Wide range of operation</li> <li>Large capacity outdoor unit (Up to 60HP)</li> <li>VTCC, Continuous heating</li> </ul> 					 FDC280-335			 FDC400 - 560			 FDC615-670		
<b>KXZ2</b> <b>Hi-COP combination</b> <ul style="list-style-type: none"> <li>Higher energy savings</li> <li>Flexible design</li> <li>VTCC, Continuous heating</li> </ul> 											 FDC560		
<b>KXZ</b> <b>Water cooled series</b> <ul style="list-style-type: none"> <li>High efficiency</li> <li>Low noise operation</li> <li>Individual control building, Large building</li> </ul> 				 FDC224 - 335				 FDC450 - 670					
<b>KX6</b> <b>High Head models Cooling only</b> <ul style="list-style-type: none"> <li>Height difference from 50m to 100m</li> <li>Wide design flexibility</li> </ul> 							 FDCH400-450			 FDCH504 - 680			
<b>Micro KXZ</b> <ul style="list-style-type: none"> <li>Space saving</li> <li>Flexible design</li> <li>Slim, light, broad range (4-6 HP)</li> <li>Small, Medium building</li> <li>Available in 1-phase and 3-Phase</li> </ul> 	 FDC112 - 155												
<b>Micro KXZ / KX</b> <ul style="list-style-type: none"> <li>Space saving</li> <li>Large number of connectable indoor units (Up to 24 Units)</li> <li>Small, Medium building</li> <li>Available in 1-phase and 3-Phase (4-6HP)</li> </ul> 	 FDC112 - 155			 FDC224 - 335									
<b>KXZ Lite</b> <ul style="list-style-type: none"> <li>Space saving</li> <li>High efficiency</li> <li>Tropical usage mode</li> <li>Easy transportation &amp; Installation</li> </ul> 				 FDC224-280									

Refrigerant

● : R32

● : R410A



	26HP	28HP	30HP	32HP	34HP	36HP	38HP	40HP	42HP	44HP	46HP	48HP	50HP	52HP	54HP	56HP	58HP	60HP		
	73.5	80.0	85.0	90.0	95.0	100.0	106.0	112.0	120.0	125.0	130.0	135.0	142.5	145.0	150.0	156.0	162.0	168.0		
	250,800	273,000	290,000	307,100	324,100	341,200	361,700	382,100	409,400	426,500	443,600	460,600	486,200	494,700	511,800	532,200	552,700	573,200		
	 FDC735	 FDC800 - 1120							 FDC1200 - 1680											
	●	●	●	●	●	●	●	●	●	●	●	●	●	●	●	●	●	●		
			 FDC850 - 1000				 FDC1060		 FDC1120											
			●	●	●	●	●	●												
	 FDC735	 FDC800 - 1120							 FDC1200 - 1680											
	●	●	●	●	●	●	●	●	●	●	●	●	●	●	●	●	●	●		
			 FDC850 - 1000				 FDC1060		 FDC1120											
			●	●	●	●	●	●												
		 FDC730 - 1000																		
	●	●	●	●	●	●														
	 FDCH735 - 900			 FDCH960			 FDCH1010 - 1360													
	●	●	●	●	●	●	●	●	●	●	●	●	●							

# Outdoor units

## High Efficiency & Comfort

### Improved Efficiency

The graphs below highlight the improved efficiencies of the KXZ2 standard and Hi-COP models compared to the previous models.

Comparison of EER in cooling mode

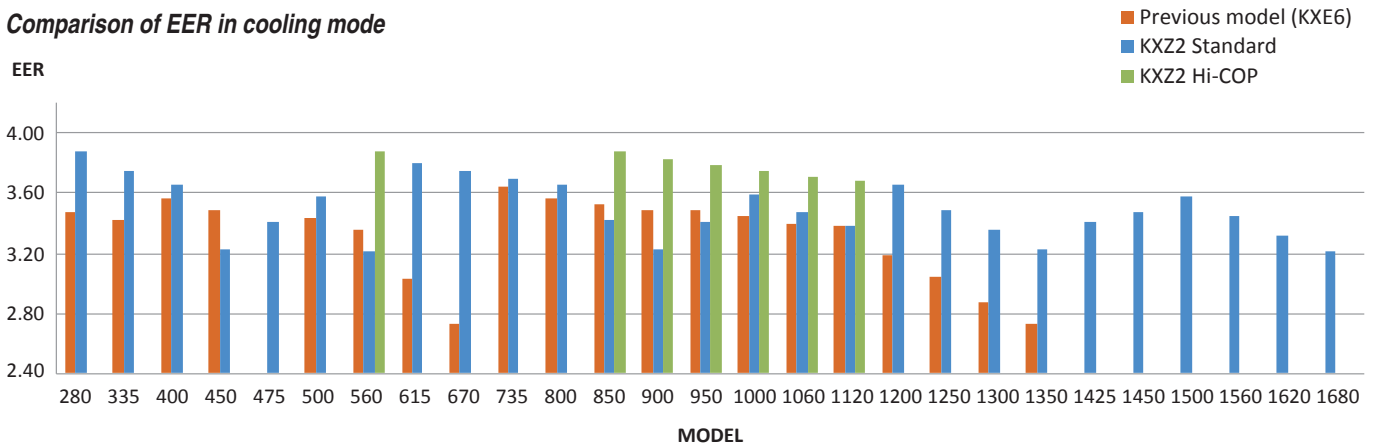

Comparison of COP in heating mode

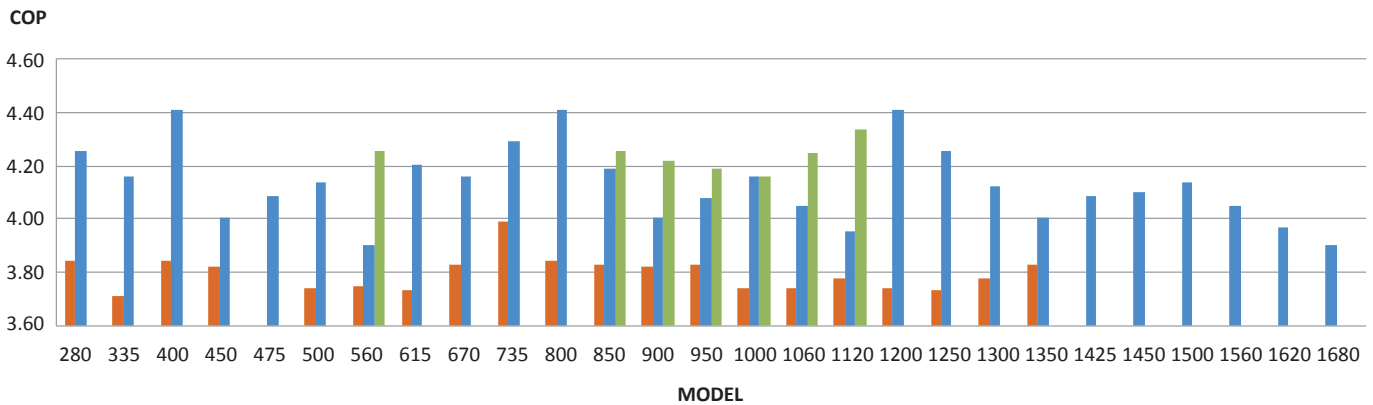

### High efficiency and compact design are achieved by applying advanced components

#### 10-60HP

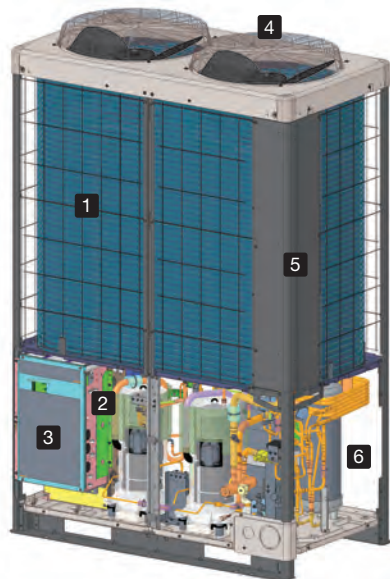

- 1 Highly efficient Heat exchanger
- 2 Optimised duct shape
- 3 New inverter control
- 4 DC Fan Motor
- 5 Rounded design
- 6 Compressor

The compressor has improved the units efficiency by innovating the thrust plate. Resulting a reduced friction loss, and increased reliability.

## Variable Temperature and Capacity Control

### VTCC

- The VTCC is a energy saving function designed by Mitsubishi Heavy Industries Thermal Systems.
- A new feature to all our KXZ ranges which provides up to 34%\* energy savings in both cooling and heating mode.
- VTCC is a function specifically designed to maximise energy savings in partial load conditions throughout all seasons.



\*34% energy savings are based on comparison with a KXZ standard model with VTCC vs. a KXZ standard model both under partial load condition.

#### Normal operation (in the cooling mode)

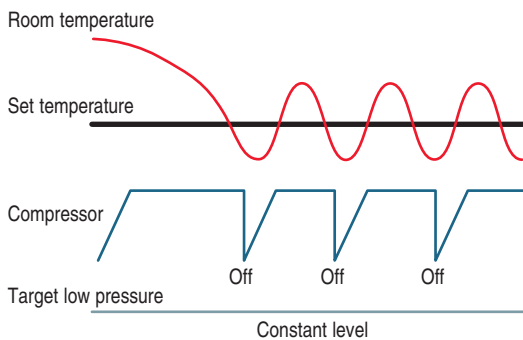

#### Energy saving operation (in the cooling mode)

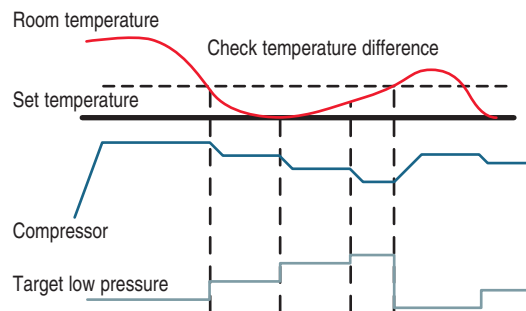

VTCC adjusts the target pressure of the refrigerant cycle in the outdoor unit automatically according to the demand of the indoor units in partial load conditions. These smooth adjustments ensure an optimal capacity usage of the indoor units as well as maximised energy savings. Ultimately this also increases comfort for the user. For example, in partial load conditions where you have low cooling and heating requirements, VTCC reduces the compressor frequency and controls the actuators in the outdoor unit. Overall with the VTCC functionality you will always have an additional energy saving of up to 34% (depending on configuration and usage of system) in low cooling and heating load requirements.

## Continuous Heating Capacity Control (CHCC)

Our defrosting control achieves more capacity than that of previous model in low ambient temperature condition. Target pressure is controlled automatically before capacity drops, which makes longer period of heating operation and shoreter defrosting time.

## Multiport compressor that achieves high efficiency

The multiport discharge area in the compressor has optimized pressure control with better balancing. The performance improvement at medium Hz has resulted in higher annual efficiencies.

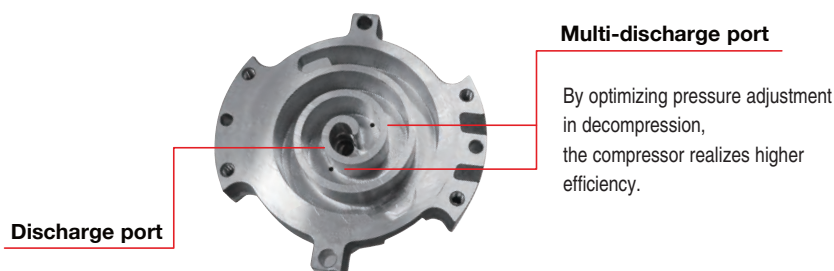

## Concentrated winding motor achieves "High Output" and "Total Efficiency Improvement"

The high performance CPU enables high precision optimization for compressor speed, which leads to concentrated winding motor use. Our product achieves high output and better energy saving effects and in particular improves seasonal efficiency rating.

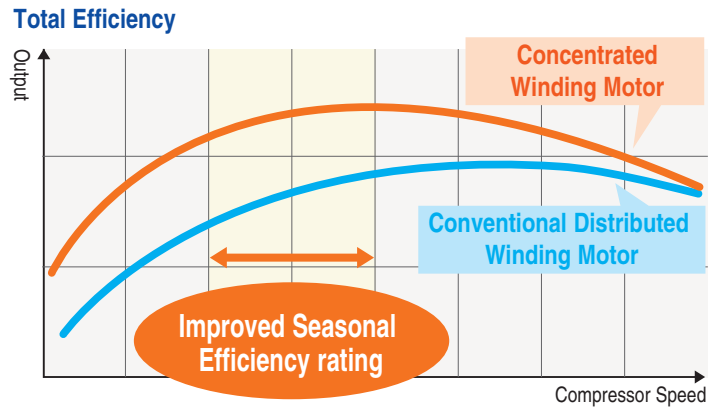

## Energy efficient Heat-exchanger

With piping layout rearranged from header to heat exchanger, refrigerant distribution flow has improved and maximum energy efficiency has been achieved.

Furthermore due to expansion of effective the heat transfer area in heat exchanger, energy efficiency has increased.

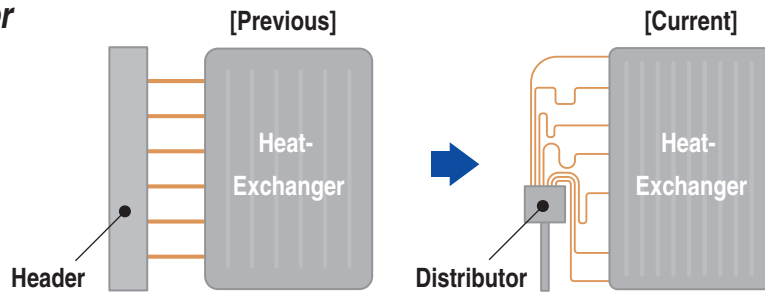

## Strengthened resistance against frost

Resistance against frost has been strengthened by adopting the energy efficient heat-exchanger.

## Vector control

Applied Vector control has a high efficiency and many new advanced features.

- Smooth operation from low speed to high speed
- Smooth Sine Voltage Wave form are attained
- Energy efficiency is further improved in low speed range

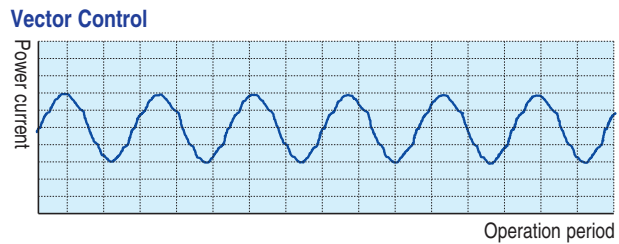

## DC Fan Motor

Adoption of DC fan motor has enabled to realize an excellent efficiency of approximate 60% higher than previous models.

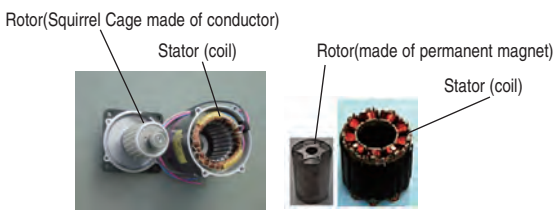

## Oil level control capability

Our proprietary technology adjusts the oil level when combining two or three outdoor units, achieving level operation rate, keeping performance of the units and ensuring long life of the system.

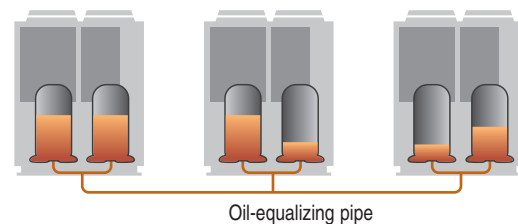

## Capacity control

The peak cut function can easily be set on the controller. This function makes the control of the capacity easier and allow a better energy management over the long term. Four steps of capacity control are available with 80%, 60%, 40%, 0% (off). Schedule can be set up to 4 operations/day.

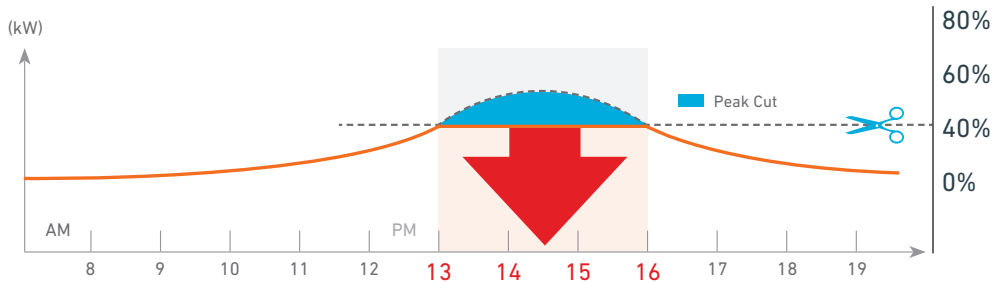

## 4-6HP (Micro KXZ)

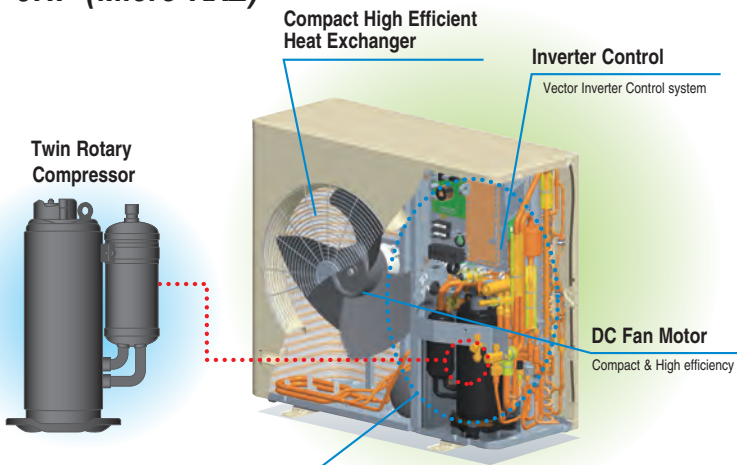

### Optimum Refrigerant System Control

- Optimum heat exchanger refrigerant distribution
- Advanced refrigerant liquid return protection control system
- High speed system control by Superlink system

## Compact high efficiency Heat Exchanger

- Optimizing relationship of the air flow velocity & fin pattern
- Improvement of air distribution Maximizing efficiency of heat exchanger



## Compact Integrated PCB

- Control Box size reduction
- PCB size reduced by 50%
  - Control PCB: Single-sided board → Double-sided board
  - Inverter PCB: Power transistor size reduction
- Superlink system control
- Design method applied

## 8-12HP (Micro)

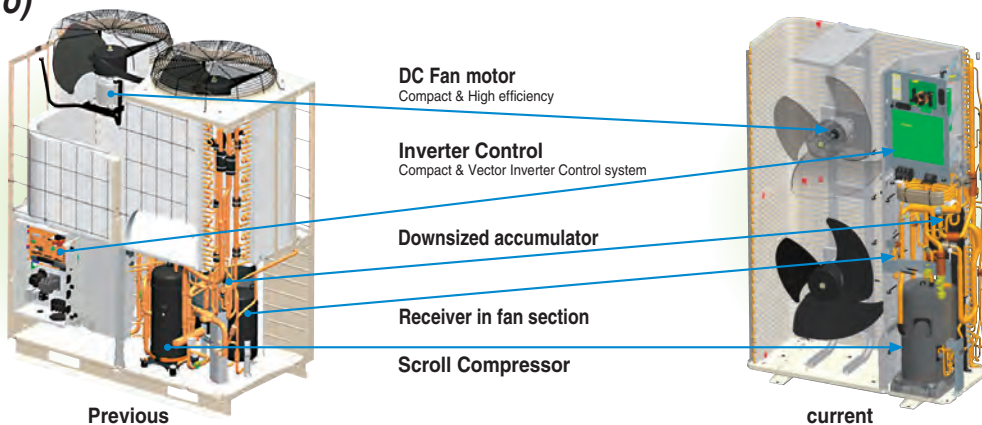

# Design Flexibility

## Indoor unit capacity connection

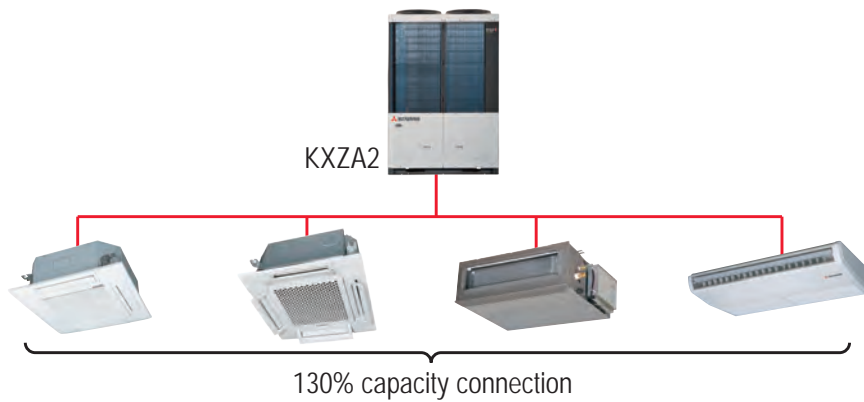

	HP	Capacity connection
Micro KXZ	4-6	<b>150%</b>
Micro KX	8-12	<b>150%</b>
KXZ Lite	8-10	<b>120%</b>
Standard KXZA2	10-60	<b>130%</b>
KXZ2 PLUS	10-16	<b>200%</b>
	17-34	<b>160%</b>
	36-60	<b>130%</b>

## Connectable indoor units

Micro KXZ	HP	4	5	6	Micro KX	8	10	12	KXZ Lite	HP	8	10			
	Numbers	8	10*	10*		22	24	24		Numbers	8	8			
Standard KXZA2	HP	10	12	14	16	17	18	20	22	24	26	28	30	32	34
	Numbers	24	27	34	39	41	43	45	53	58	63	69	73	78	80
	HP	36	38	40	42	44	46	48	50	52	54	56	58	60	
	Numbers	80	80	80	80	80	80	80	80	80	80	80	80	80	80
KXZ2 PLUS	HP	10	12	14	16	17	18	20	22	24	26	28	30	32	34
	Numbers	37	44	53	60	50	53	59	65	71	78	80	80	80	80
	HP	36	38	40	42	44	46	48	50	52	54	56	58	60	
	Numbers	80	80	80	80	80	80	80	80	80	80	80	80	80	80

\*When connecting 9 units or more, set the total capacity as follows : 5HP : 110% or less, 6HP : 100% or less. In the case of KXZ(R410A).

## Wide Range of Operation

KXZ series permits an extensible system design with a heating range operation down to -20°C and a cooling range operation up to 46°C. Furthermore KXZ2 PLUS extends a cooling range operation up to 52°C.

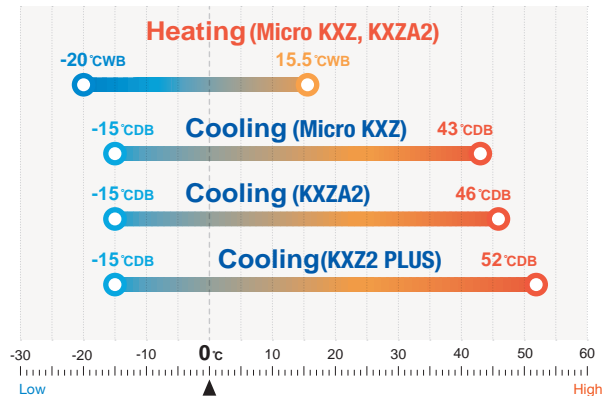

## Control Systems

All series offer wide choice of control system and provide the best solution.

[Control system units with SUPERLINK-II]

Classification	Type	Model	Connectable Indoor units (Maximum)	Electric power calculation
Individual controller	Wired	RC-E5	16	—
		RC-EX3D	16	—
	Wireless	RCN-T-5BW-E2 etc.	16	—
Center Console	Push buttons	SC-SL1N-E	16	—
		SC-SL2NA-E	64	—
	Touch screen	SC-SL5-E	256	●
	BMS interface units	Web & BACnet gateway	SC-WBGW256	256(128x2)

## Long Pipe Length 10-60HP

Total length :

**1,000m**

Furthest indoor unit:

Actual length: **160m**

Equivalent length: **185m**

The maximum height difference between indoor units has been increased to a maximum of 30m, and the maximum height difference between the outdoor unit and indoor unit has been expanded to 90m. For with few limitations, contributes to system design flexibility.

\*1 The difference between the longest and the shortest indoor unit piping from the first branch must be within 40m. (MAX85m)

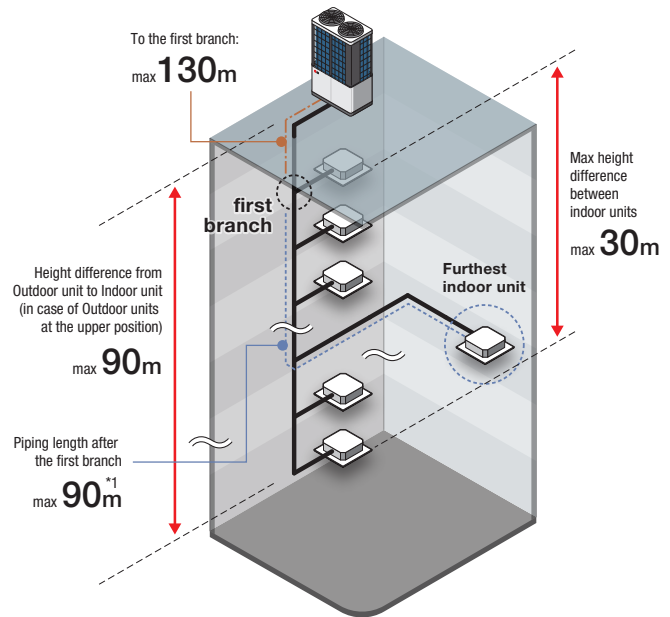

## Easy Transportation & Installation

Due to realization of significant reduction in size and footprint which is one of the smallest in the industry, transportation in an elevator made for six persons (Width:1400mm, Depth:850, Open area:800mm) is possible, eliminating cost of a crane and reducing labor.

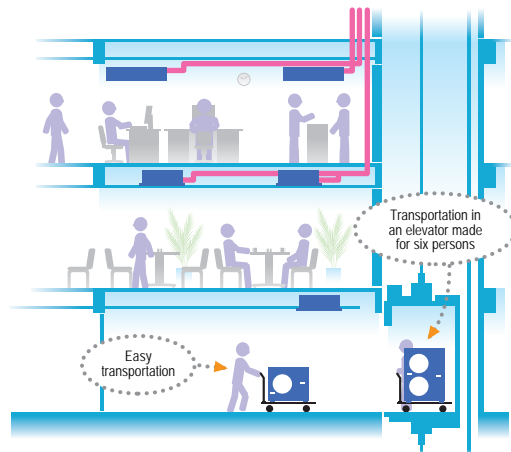
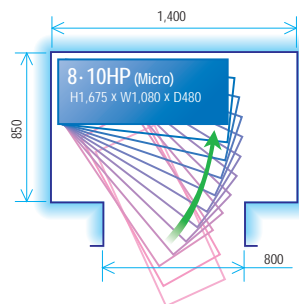

KXZ is portable and the uniform reduced footprint allows neat, continuous installation.

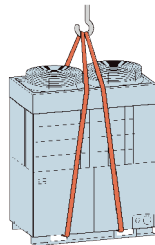

## Blue Fin

Due to application of blue coated fins on the heat exchanger of the new outdoor unit, corrosion resistance has been improved compared to previous models.

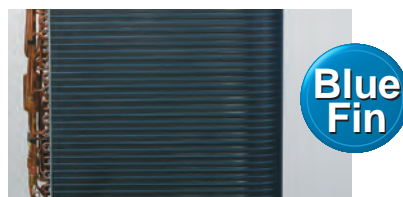

## Priority operation mode rule

User can select the following priority operation mode. (for whole system)

1. First unit's operation mode (by default setting)
2. Last unit's operation mode
3. Majority operation mode (see below)
4. Master operation mode (see below)

### <Majority operation mode>

The system is operated according to the mode selected by the majority of units in operation (whichever greater capacity between the sums of cooling mode and heating mode). The operation mode in minority is set to fan mode automatically.

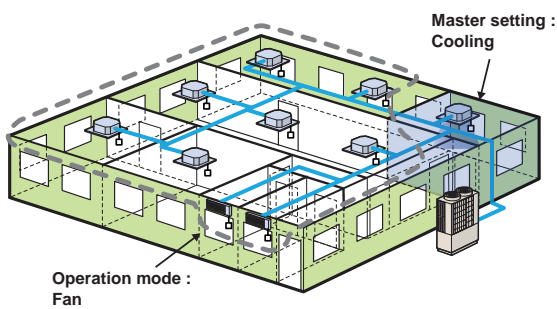

### <Master operation mode>

The system is operated according to master operation mode. When master operation mode is set at cooling mode, units selected as heating mode is set to fan mode automatically.

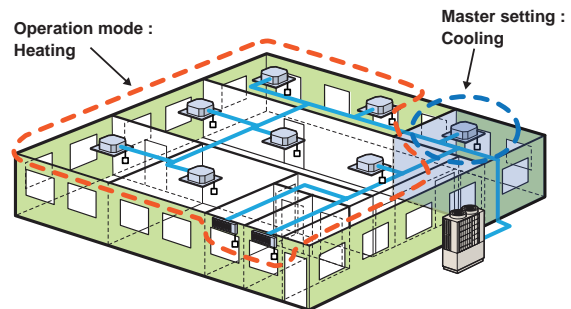

## Fixed Cooling mode/fixed heating mode (summer/winter switch)

It is possible to fix the operational mode of the system (either cooling or heating) using a switch (SW3-7) on the outdoor unit PC board - this enables the building user to decide the operation of the system (e.g. cooling only in summer/heating only in winter), to avoid unnecessary energy wastage. It is also possible to wire the control switch to a remote location (inside the building) to a control room, or even linked to an ambient thermostat.

## Serviceability

### Easy Service

Quick and easy access to service parts by separation of compartments.

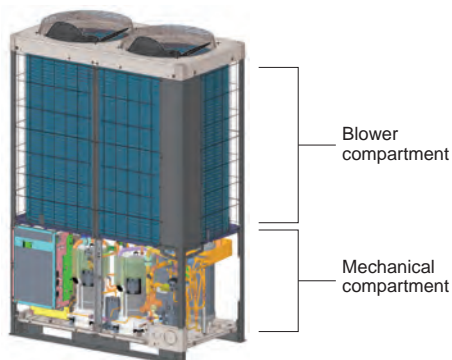

### Check Operation (10-60HP)

Closing of Service valve, crossing connection of refrigerant piping and electrical wiring, proper operation of EEV (Electrical Expansion Valve) can be checked automatically in cooling operation. This check operation can be done at 0–43°C outdoor temperature and 10–32°C indoor temperature by use of outdoor unit dip switch. The check should be done in one refrigerant system. It takes 15–30 minutes and avoids frequent failure by preventing careless mistakes during installation.

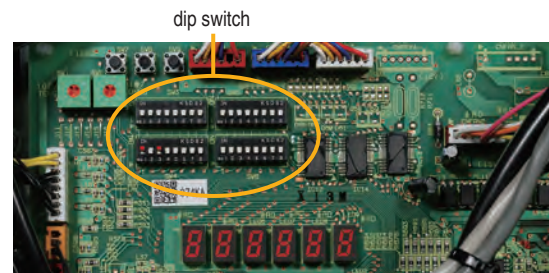



## 10,12HP (28.0kW, 33.5kW)



Model No.	Nominal Cooling Capacity
FDC280CKXZA2S	28.0kW
FDC335CKXZA2S	33.5kW

**New!**

- The KXZ2 PLUS series has a layered design and a refined new form.
- Connect up to 44 indoor units/up to 200% capacity.
- High efficiency with EER up to 3.86.



Uniform footprint of models allows continuous side-by-side installation

Total length :  
**1,000m**

Furthest indoor unit:  
Actual length: **160m**  
Equivalent length: **185m**

\*1 The difference between the longest and the shortest indoor unit piping from the first branch must be within 40m. (MAX85m)

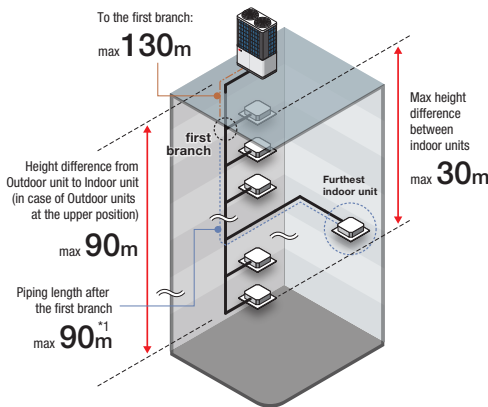

Cooling use in high ambient temperature  
**Wide range operation**

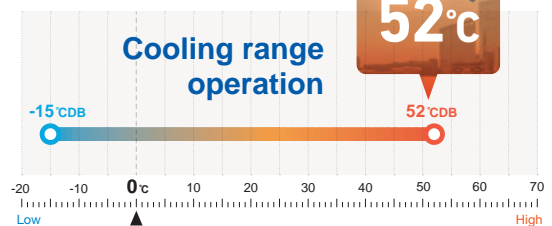

\* With limitation to piping length and height difference between indoor and outdoor units.

Extended external static pressure

Max:  
**50 Pa to 85 Pa**

Flexibility to meet installation location needs.

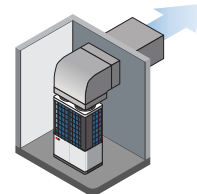

## Specifications

Item	Model	FDC280CKXZA2S	FDC335CKXZA2S		
Nominal horse power		10HP	12HP		
Power source		3 Phase 380-415V, 50Hz			
Starting current	A	5			
Max current	A	20.1			
Nominal capacity	Cooling	kW	28.0	33.5	
Electrical characteristics	Power consumption	Cooling	kW	7.25	8.98
Exterior dimensions	HxWxD	mm	1697x1350x720		
Net weight		kg	288		
Sound pressure level	Cooling	dB(A)	56	63	
Refrigerant	Type / GWP		R410A / 2088		
	Charge	kg/TCO <sub>2</sub> Eq	11.0 / 22.968		
Refrigerant piping size	Liquid line	mm(in)	ø9.52(3/8")	ø12.7(1/2")	
	Gas line		ø22.22(7/8")	ø25.4(1") [ø22.22(7/8")]	
Capacity connection		%	50-200		
Number of connectable indoor units			37	44	

1. The data are measured under the following conditions(ISO-T1). Cooling: Indoor temp. of 27°CDB, 19°CWB, and outdoor temp. of 35°CDB.  
 2. Sound pressure level indicates the value in an anechoic chamber. During operation these values are somewhat higher due to ambient conditions.  
 3. 'tonne(s) of CO<sub>2</sub> equivalent' means a quantity of greenhouse gases- expressed as the product of the weight of the greenhouse gases in metric tonnes and of their global warming potential.  
 4. [ ] : Pipe sizes applicable to European installations are shown in parentheses.

# Dimensions

All measurements in mm.

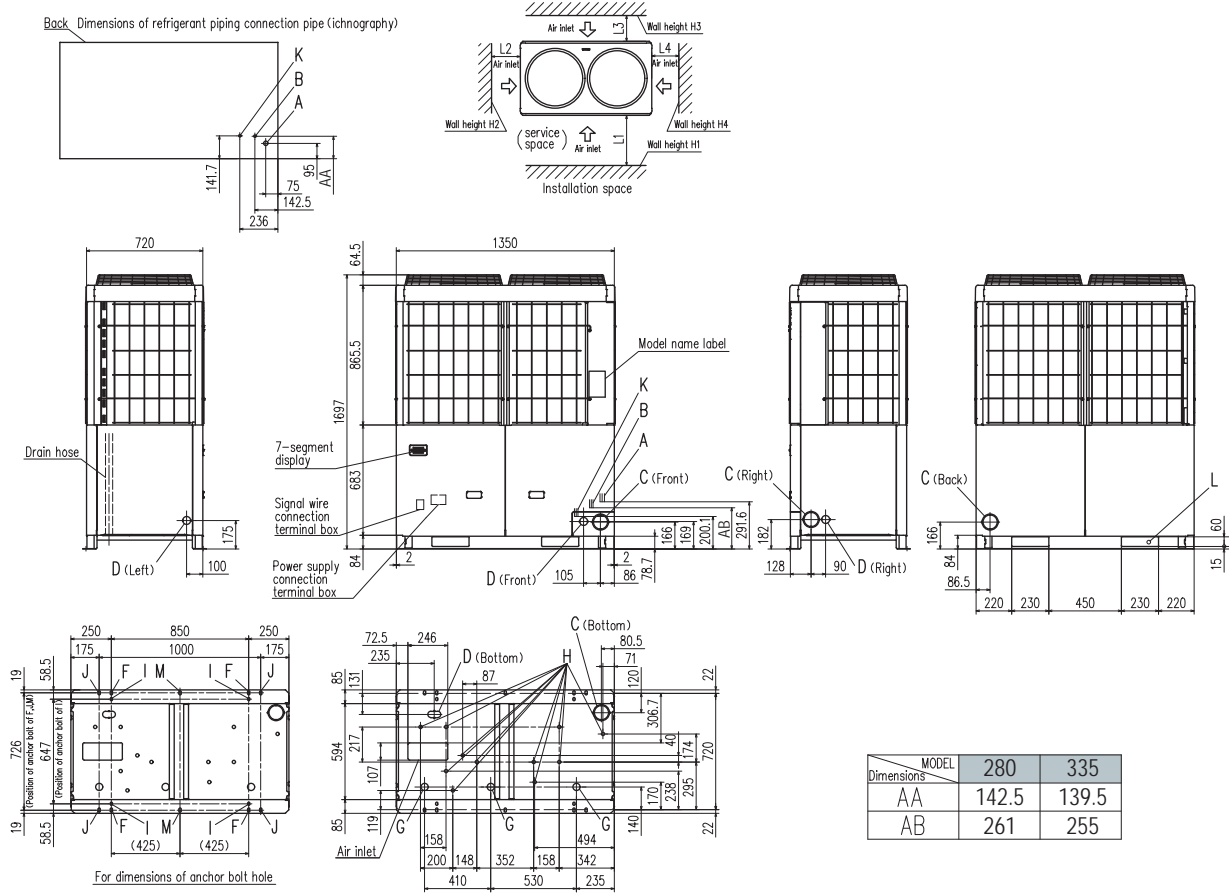

Mark	Content	280	335
A	Refrigerant gas piping connection pipe	ø22.22(Brazing)	ø25.4(Brazing)
B	Refrigerant liquid piping connection pipe	ø9.52(Flare)	ø12.7(Flare)
C	Refrigerant piping exit hole	ø88(or ø100)	
D	Power supply entry hole	ø50 (right · left · front), long hole 40 x 80 (bottom)	
F	Anchor bolt hole	M10 x 4 places	
G	Drain waste water hose hole	ø45 x 3 places	
H	Drain hole	ø20 x 11 places	
K	Refrigerant oil equalization piping connection pipe	ø9.52(Flare)	
L	Carrying in or hole for hanging	230 x 60	

Installation example		
Dimensions	1	2
L1	500	Open
L2	10(30)	10(30)
L3	100	100
L4	10(30)	Open
H1	1500	Open
H2	No limit	No limit
H3	1000	No limit
H4	No limit	Open

() :In case it is the promised installation location that the outdoor unit is used on conditions with the ambient temperature of 43°C or more.

## When more than one unit is installed

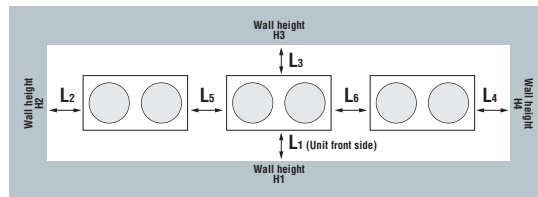

Installation example		
Dimensions	1	2
L1	500	Open
L2	10(30)	200
L3	100	300
L4	10(30)	Open
L5	10(30)	400
L6	10(30)	400
H1	1500	Open
H2	No limit	No limit
H3	1000	No limit
H4	No limit	Open

## 14-20HP (40.0kW – 56.0kW)



Model No.	Nominal Cooling Capacity
FDC400CKXZA2S	40.0kW
FDC450CKXZA2S	45.0kW
FDC475CKXZA2S	47.5kW
FDC500CKXZA2S	50.0kW
FDC560CKXZA2S	56.0kW

**New!**

- The KXZ2 PLUS series has a layered design and a refined new form.
- Connect up to 59 indoor units/up to 160% capacity. ( FDC400 - 450:200% )
- High efficiency with EER up to 3.64.



Uniform footprint of all models allows continuous side-by-side installation

Total length :  
**1,000m**

**Furthest indoor unit:**  
Actual length: **160m**  
Equivalent length: **185m**

\*1 The difference between the longest and the shortest indoor unit piping from the first branch must be within 40m. (MAX85m)

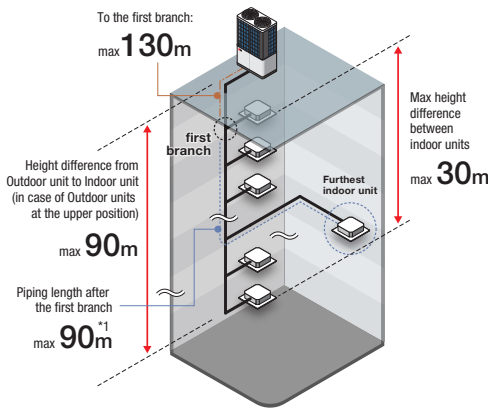

Cooling use in high ambient temperature  
**Wide range operation**

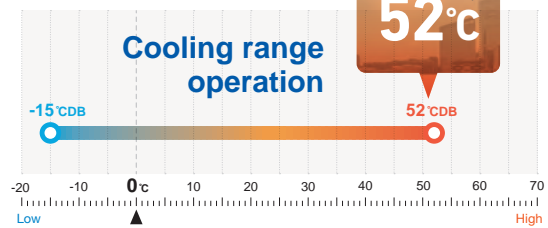

\* With limitation to piping length and height difference between indoor and outdoor units.

**Extended external static pressure**

Max:  
**50 Pa to 85 Pa**

Flexibility to meet installation location needs.

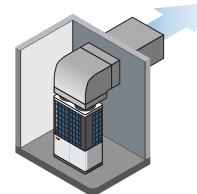

## Specifications

Item		Model	FDC400CKXZA2S	FDC450CKXZA2S	FDC475CKXZA2S	FDC500CKXZA2S	FDC560CKXZA2S
Nominal horse power			14HP	16HP	17HP	18HP	20HP
Power source			3 Phase 380-415V, 50Hz				
Starting current		A	5			8	
Max current		A	32.0			40.2	
Nominal capacity	Cooling	kW	40.0	45.0	47.5	50.0	56.0
Electrical characteristics	Power consumption	Cooling kW	10.98	13.98	13.97	14.01	17.50
Exterior dimensions	HxWxD	mm	2052x1350x720				
Net weight		kg	332			378	
Sound pressure level	Cooling	dB(A)	60	61	61	61	63
Refrigerant	Type / GWP		R410A / 2088				
	Charge	kg/TCO2Eq	11.5 / 24.012				
Refrigerant piping size	Liquid line	mm(in)	ø12.7(1/2")				
	Gas line		ø25.4(1") [ø28.58(1-1/8")]	ø28.58(1-1/8")			
Capacity connection		%	50-200			50-160	
Number of connectable indoor units			53	60	50	53	59

1. The data are measured under the following conditions(ISO-T1). Cooling: Indoor temp. of 27°CDB, 19°CWB, and outdoor temp. of 35°CDB.  
 2. Sound pressure level indicates the value in an anechoic chamber. During operation these values are somewhat higher due to ambient conditions.  
 3. 'tonne(s) of CO<sub>2</sub> equivalent' means a quantity of greenhouse gases- expressed as the product of the weight of the greenhouse gases in metric tonnes and of their global warming potential.  
 4. [ ] : Pipe sizes applicable to European installations are shown in parentheses.

# Dimensions

All measurements in mm.

Back Dimensions of refrigerant piping connection pipe (ichnography)

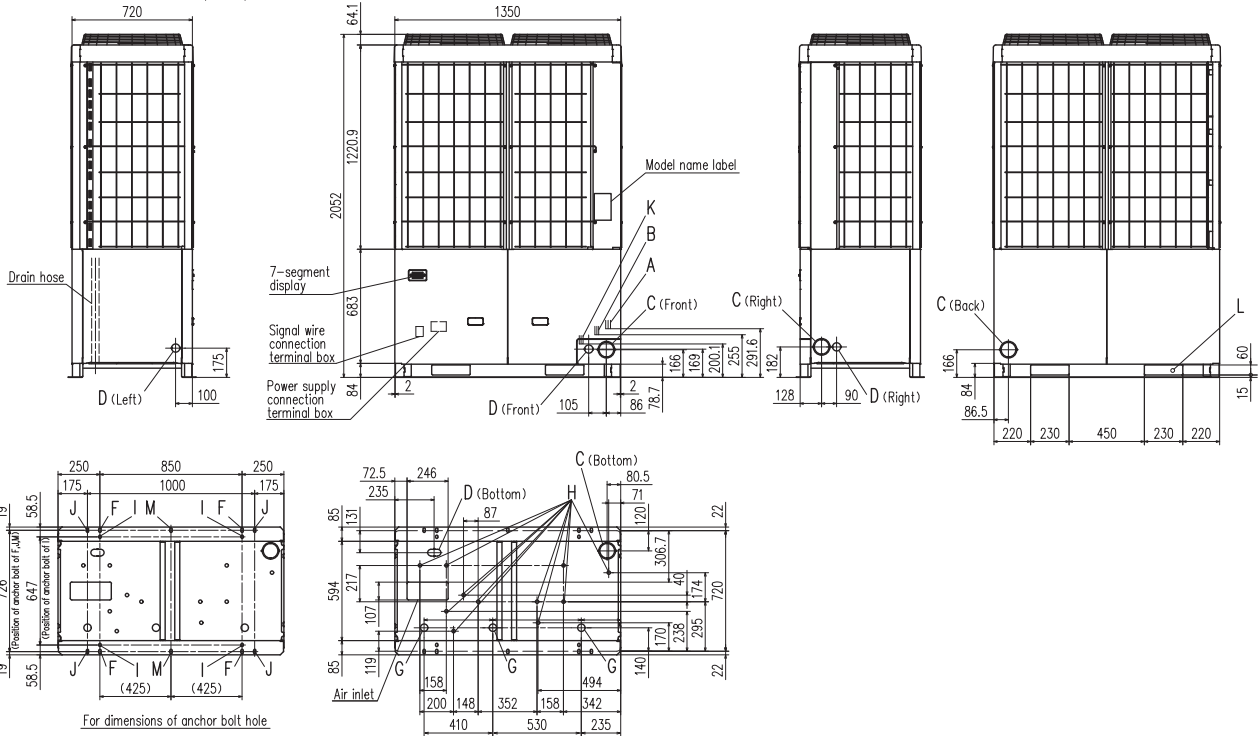
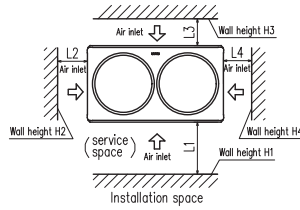
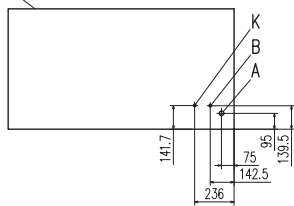

Mark	Content	400	450, 475, 500, 560
A	Refrigerant gas piping connection pipe	ø25.4(Brazing)	ø28.58(Brazing)
B	Refrigerant liquid piping connection pipe	ø12.7(Flare)	
C	Refrigerant piping exit hole	ø88(or ø100)	
D	Power supply entry hole	ø50 (right · left · front), long hole 40 x 80 (bottom)	
F	Anchor bolt hole	M10 x 4 places	
G	Drain waste water hose hole	ø45 x 3 places	
H	Drain hole	ø20 x 11 places	
K	Refrigerant oil equalization piping connection pipe	ø9.52(Flare)	
L	Carrying in or hole for hanging	230 x 60	

Installation example		
Dimensions	1	2
L1	500	Open
L2	10(30)	10(30)
L3	100	100
L4	10(30)	Open
H1	1500	Open
H2	No limit	No limit
H3	1000	No limit
H4	No limit	Open

():In case it is the promised installation location that the outdoor unit is used on conditions with the ambient temperature of 43°C or more.

## When more than one unit is installed

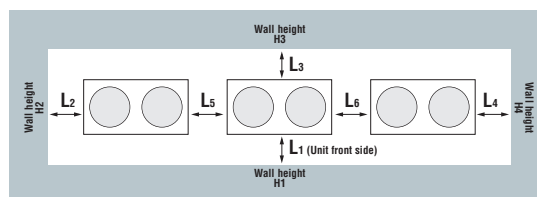

Installation example		
Dimensions	1	2
L1	500	Open
L2	10(30)	200
L3	100	300
L4	10(30)	Open
L5	10(30)	400
L6	10(30)	400
H1	1500	Open
H2	No limit	No limit
H3	1000	No limit
H4	No limit	Open

## 22,24HP (61.5kW, 67.0kW)



Model No.	Nominal Cooling Capacity
FDC615CKXZA2S	61.5kW
FDC670CKXZA2S	67.0kW

**New!**



- The KXZ2 PLUS series has a layered design and a refined new form.
- Connect up to 71 indoor units/up to 160% capacity.
- High efficiency with EER up to 3.79.

Total length :  
**1,000m**

Furthest indoor unit:  
Actual length: **160m**  
Equivalent length: **185m**

\*1 The difference between the longest and the shortest indoor unit piping from the first branch must be within 40m. (MAX85m)

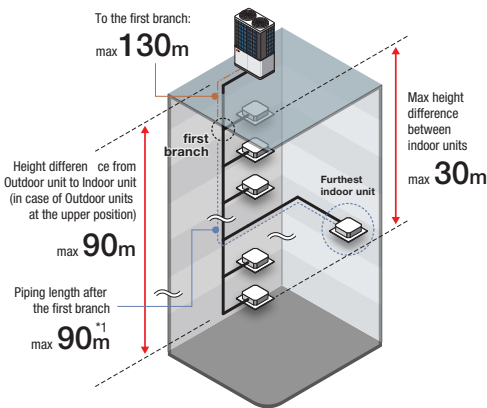

Cooling use in high ambient temperature  
Wide range operation

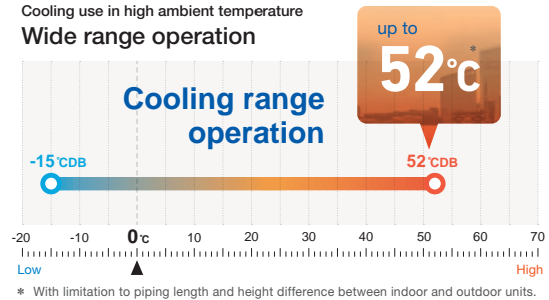

Extended external static pressure

Max:  
**50 Pa to 85 Pa**

Flexibility to meet installation location needs.

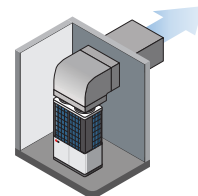

## Specifications

Exterior dimension : Please refer to page 31.

Item		Model	FDC615CKXZA2S	FDC670CKXZA2S
Combination (FDC)			280CKXZA2S 335CKXZA2S	335CKXZA2S 335CKXZA2S
Nominal horse power			22HP	24HP
Power source			3 Phase 380-415V, 50Hz	
Starting current		A	10	
Max current		A	40.2	
Nominal capacity	Cooling	kW	61.5	67.0
Electrical characteristics	Power consumption	Cooling kW	16.24	17.96
Net weight		kg	576	
Refrigerant charge	R410A	kg	11.0x2	
Refrigerant piping size	Liquid line	mm(in)	ø12.7(1/2")	
	Gas line		ø28.58(1-1/8")	
Capacity connection		%	50-160	
Number of connectable indoor units			65	71

1. The data are measured under the following conditions(ISO-T1). Cooling: Indoor temp. of 27°CDB, 19°CWB, and outdoor temp. of 35°CDB.  
2.Sound pressure level indicates the value in an anechoic chamber. During operation these values are somewhat higher due to ambient conditions.

## 26-40HP (73.5kW – 112.0kW)



Model No.	Nominal Cooling Capacity
FDC735CKXZA2S	73.5kW
FDC800CKXZA2S	80.0kW
FDC850CKXZA2S	85.0kW
FDC900CKXZA2S	90.0kW
FDC950CKXZA2S	95.0kW
FDC1000CKXZA2S	100.0kW
FDC1060CKXZA2S	106.0kW
FDC1120CKXZA2S	112.0kW

**New!**



FDC735

- The KXZ2 PLUS series has a layered design and a refined new form.
- Connect up to 80 indoor units/up to 160% capacity. ( FDC1000 - 1120:130% )
- High efficiency with EER up to 3.68.
- Industry leading total piping length up to 1000m and a maximum height difference between indoor units has been increased to maximum of 30m.

Cooling use in high ambient temperature  
Wide range operation

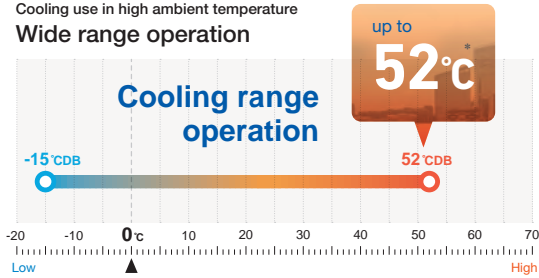

\* With limitation to piping length and height difference between indoor and outdoor units.

Extended external static pressure

Max:  
50 Pa to 85 Pa

Flexibility to meet installation location needs.

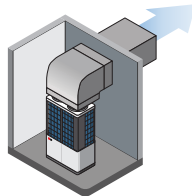

FDC800 - 1120

## Specifications

Exterior dimension : Please refer to page 31, 33.

Item			Model	FDC735CKXZA2S	FDC800CKXZA2S	FDC850CKXZA2S	FDC900CKXZA2S	FDC950CKXZA2S	FDC1000CKXZA2S	FDC1060CKXZA2S	FDC1120CKXZA2S	
Combination (FDC)				335CKXZA2S	400CKXZA2S	400CKXZA2S	450CKXZA2S	475CKXZA2S	500CKXZA2S	500CKXZA2S	560CKXZA2S	
				400CKXZA2S	400CKXZA2S	450CKXZA2S	450CKXZA2S	475CKXZA2S	500CKXZA2S	560CKXZA2S	560CKXZA2S	
Nominal horse power				26HP	28HP	30HP	32HP	34HP	36HP	38HP	40HP	
Power source				3 Phase 380-415V, 50Hz								
Starting current			A	10				16				
Max current			A	52.1	64.0			80.4				
Nominal capacity		Cooling	kW	73.5	80.0	85.0	90.0	95.0	100.0	106.0	112.0	
Electrical characteristics		Power consumption	Cooling	kW	19.96	21.96	24.96	27.95	27.94	28.02	31.51	35.00
Net weight			kg	620	664			756				
Refrigerant charge		R410A	kg	11.0+11.5	11.5x2							
Refrigerant piping size		Liquid line	mm(in)	ø15.88(5/8")						ø19.05(3/4")		
		Gas line		ø31.75(1-1/4") [ø34.92(1-3/8")]						ø38.1(1-1/2") [ø34.92(1-3/8")]		
Capacity connection			%	50-160				50-130				
Number of connectable indoor units				78	80							

1. The data are measured under the following conditions(ISO-T1). Cooling: Indoor temp. of 27°CDB, 19°CWB, and outdoor temp. of 35°CDB.

2. Sound pressure level indicates the value in an anechoic chamber. During operation these values are somewhat higher due to ambient conditions.

3. [ ] : Pipe sizes applicable to European installations are shown in parentheses.

## 42-48HP (120.0kW – 135.0kW)



Model No.	Nominal Cooling Capacity
FDC1200CKXZA2S	120.0kW
FDC1250CKXZA2S	125.0kW
FDC1300CKXZA2S	130.0kW
FDC1350CKXZA2S	135.0kW

- The KXZ2 PLUS series has a layered design and a refined new form.
- Connect up to 80 indoor units/up to 130% capacity.
- High efficiency with EER up to 3.64.

**New!**



FDC1200 – 1350

Total length :  
**1,000m**

Furthest indoor unit:  
Actual length: **160m**  
Equivalent length: **185m**

\*1 The difference between the longest and the shortest indoor unit piping from the first branch must be within 40m. (MAX85m)

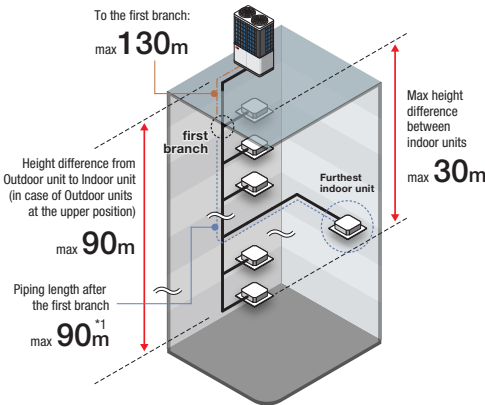

Cooling use in high ambient temperature  
**Wide range operation**

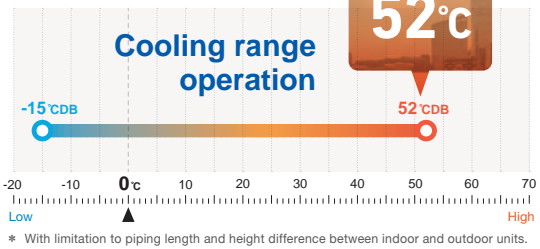

**Extended external static pressure**

Max:  
**50 Pa to 85 Pa**

Flexibility to meet installation location needs.

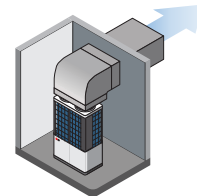

## Specifications

Exterior dimension : Please refer to page 33.

Item			Model	FDC1200CKXZA2S	FDC1250CKXZA2S	FDC1300CKXZA2S	FDC1350CKXZA2S
Combination (FDC)				400CKXZA2S	400CKXZA2S	400CKXZA2S	450CKXZA2S
				400CKXZA2S	400CKXZA2S	450CKXZA2S	450CKXZA2S
				400CKXZA2S	450CKXZA2S	450CKXZA2S	450CKXZA2S
Nominal horse power				42HP	44HP	46HP	48HP
Power source				3 Phase 380-415V, 50Hz			
Starting current			A	15			
Max current			A	96.0			
Nominal capacity	Cooling		kW	120.0	125.0	130.0	135.0
Electrical characteristics	Power consumption	Cooling	kW	32.94	35.94	38.93	41.93
			kg	996			
Refrigerant charge	R410A		kg	11.5x3			
Refrigerant piping size	Liquid line		mm(in)	ø19.05(3/4")			
	Gas line			ø38.1(1-1/2") [ø34.92(1-3/8")]			
Capacity connection			%	50-130			
Number of connectable indoor units				80			

1. The data are measured under the following conditions(ISO-T1). Cooling: Indoor temp. of 27°CDB, 19°CWB, and outdoor temp. of 35°CDB.  
2. Sound pressure level indicates the value in an anechoic chamber. During operation these values are somewhat higher due to ambient conditions.  
3. [ ] : Pipe sizes applicable to European installations are shown in parentheses.

## 50-60HP (142.5kW – 168.0kW)



Model No.	Nominal Cooling Capacity
FDC1425CKXZA2S	142.5kW
FDC1450CKXZA2S	145.0kW
FDC1500CKXZA2S	150.0kW
FDC1560CKXZA2S	156.0kW
FDC1620CKXZA2S	162.0kW
FDC1680CKXZA2S	168.0kW

- The KXZ2 PLUS series has a layered design and a refined new form.
- Connect up to 80 indoor units/up to 130% capacity.
- High efficiency with EER up to 3.57.

**New!**



FDC1425 – 1680

Total length :  
**1,000m**

Furthest indoor unit:  
Actual length: **160m**  
Equivalent length: **185m**

\*1 The difference between the longest and the shortest indoor unit piping from the first branch must be within 40m. (MAX85m)

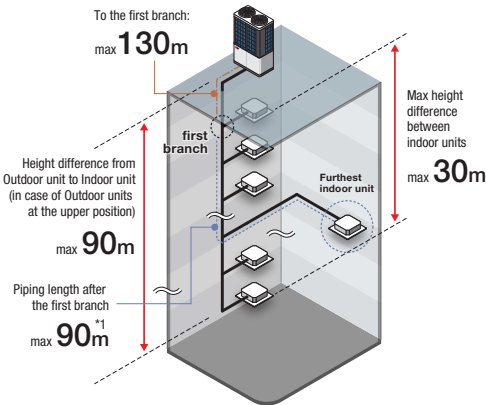

Cooling use in high ambient temperature  
**Wide range operation**

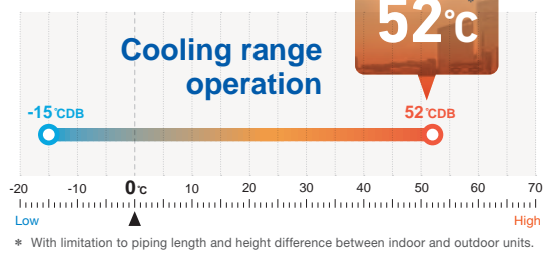

**Extended external static pressure**

Max:  
**50 Pa to 85 Pa**

Flexibility to meet installation location needs.

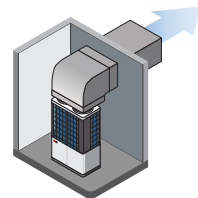

## Specifications

Exterior dimension : Please refer to page 33.

Item			Model	FDC1425CKXZA2S	FDC1450CKXZA2S	FDC1500CKXZA2S	FDC1560CKXZA2S	FDC1620CKXZA2S	FDC1680CKXZA2S
Combination (FDC)				475CKXZA2S	475CKXZA2S	500CKXZA2S	500CKXZA2S	500CKXZA2S	560CKXZA2S
				475CKXZA2S	475CKXZA2S	500CKXZA2S	500CKXZA2S	560CKXZA2S	560CKXZA2S
				475CKXZA2S	500CKXZA2S	500CKXZA2S	560CKXZA2S	560CKXZA2S	560CKXZA2S
Nominal horse power				50HP	52HP	54HP	56HP	58HP	60HP
Power source				3 Phase 380-415V, 50Hz					
Starting current			A	24					
Max current			A	120.6					
Nominal capacity	Cooling		kW	142.5	145.0	150.0	156.0	162.0	168.0
Electrical characteristics	Power consumption	Cooling	kW	41.91	41.95	42.03	45.52	49.01	52.50
	Net weight		kg	1134					
Refrigerant charge	R410A		kg	11.5x3					
Refrigerant piping size	Liquid line		mm(in)	ø19.05(3/4")					
	Gas line		mm(in)	ø38.1(1-1/2") [ø34.92(1-3/8")]					
Capacity connection			%	50-130					
Number of connectable indoor units				80					

1. The data are measured under the following conditions(ISO-T1). Cooling: Indoor temp. of 27°CDB, 19°CWB, and outdoor temp. of 35°CDB.  
2. Sound pressure level indicates the value in an anechoic chamber. During operation these values are somewhat higher due to ambient conditions.  
3. [ ] : Pipe sizes applicable to European installations are shown in parentheses.

# KXZ2 PLUS Cooling only series Hi-COP combination

## 20-40HP (56.0kW – 113.5kW)



Model No.	Nominal Cooling Capacity
FDC560CKXZA2S (FDC280+FDC280)	56.0kW
FDC850CKXZA2S (FDC280+FDC280+FDC280)	84.0kW
FDC900CKXZA2S (FDC280+FDC280+FDC335)	89.5kW
FDC950CKXZA2S (FDC280+FDC335+FDC335)	95.0kW
FDC1000CKXZA2S (FDC335+FDC335+FDC335)	100.5kW
FDC1060CKXZA2S (FDC335+FDC335+FDC400)	107.0kW
FDC1120CKXZA2S (FDC335+FDC400+FDC400)	113.5kW

**New!**



FDC560



FDC850 - 1000



FDC1060



FDC1120

- The KXZ2 PLUS series has a layered design and a refined new form.
- High efficiency with EER up to 3.86.



Total length :  
**1,000m**

Furthest indoor unit:  
Actual length: **160m**  
Equivalent length: **185m**

\*1 The difference between the longest and the shortest indoor unit piping from the first branch must be within 40m. (MAX85m)

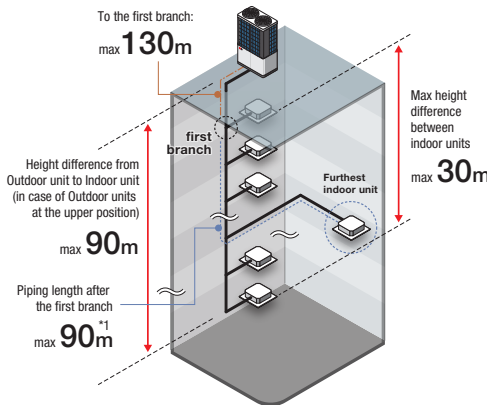

Cooling use in high ambient temperature  
Wide range operation

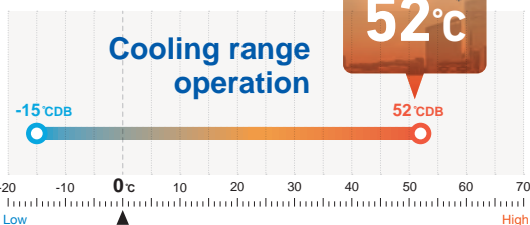

\* With limitation to piping length and height difference between indoor and outdoor units.

Extended external static pressure

Max:  
**50 Pa to 85 Pa**

Flexibility to meet installation location needs.

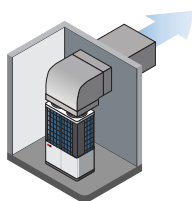

# Specifications

Item	Model	FDC560CKXZA2S	FDC850CKXZA2S	FDC900CKXZA2S	
Combination (FDC)		280CKXZA2S	280CKXZA2S	280CKXZA2S	
		280CKXZA2S	280CKXZA2S	280CKXZA2S	
		-	280CKXZA2S	335CKXZA2S	
Nominal horse power		20HP	30HP	32HP	
Power source		3 Phase 380-415V, 50Hz			
Starting current	A	10	15		
Max current	A	40.2	60.3		
Nominal capacity	Cooling	kW	56.0	84.0	89.5
Electrical characteristics	Power consumption	kW	14.51	21.76	23.49
	Cooling				
Net weight		kg	576	864	
Refrigerant charge	R410A	kg	11.0x2	11.0x3	
Refrigerant piping size	Liquid line	mm(in)	ø12.7(1/2")		
	Gas line		ø28.58(1-1/8")		
Capacity connection		%	80-160		
Number of connectable indoor units			59	80	

Item	Model	FDC950CKXZA2S	FDC1000CKXZA2S	FDC1060CKXZA2S	FDC1120CKXZA2S	
Combination (FDC)		280CKXZA2S	335CKXZA2S	335CKXZA2S	335CKXZA2S	
		335CKXZA2S	335CKXZA2S	335CKXZA2S	400CKXZA2S	
		335CKXZA2S	335CKXZA2S	400CKXZA2S	400CKXZA2S	
Nominal horse power		34HP	36HP	38HP	40HP	
Power source		3 Phase 380-415V, 50Hz				
Starting current	A	15				
Max current	A	60.3		72.2	84.1	
Nominal capacity	Cooling	kW	95.0	100.5	107.0	113.5
Electrical characteristics	Power consumption	kW	25.22	26.94	28.94	30.94
	Cooling					
Net weight		kg	864		908	952
Refrigerant charge	R410A	kg	11.0x3	11.0x2+11.5	11.0+11.5x2	
Refrigerant piping size	Liquid line	mm(in)	ø15.88(5/8")		ø19.05(3/4")	
	Gas line		ø31.75(1-1/4") [ø34.92(1-3/8")]		ø38.1(1-1/2") [ø34.92(1-3/8")]	
Capacity connection		%	80-160	80-130		
Number of connectable indoor units			80			

1. The data are measured under the following conditions(ISO-T1). Cooling: Indoor temp. of 27°CDB, 19°CWB, and outdoor temp. of 35°CDB.
2. Sound pressure level indicates the value in an anechoic chamber. During operation these values are somewhat higher due to ambient conditions.
3. [ ] : Pipe sizes applicable to European installations are shown in parentheses.

## Dimensions

Please refer to page 31, 33.

## 10,12HP (28.0kW, 33.5kW)



Model No.	Nominal Cooling Capacity
FDC280KXZA2	28.0kW
FDC335KXZA2	33.5kW

- The KXZ2 series has a layered design and a refined new form.
- Connect up to 29 indoor units/up to 130% capacity.
- High efficiency with EER up to 3.86.
- New Heating solution - Continuous Heating Capacity Control (CHCC).



Uniform footprint of models allows continuous side-by-side installation

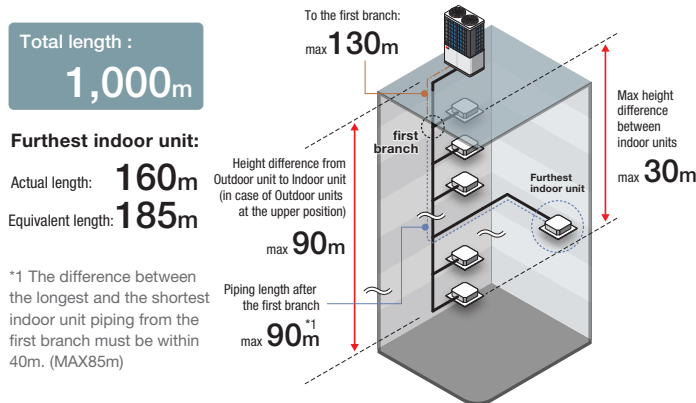

### Range of operation

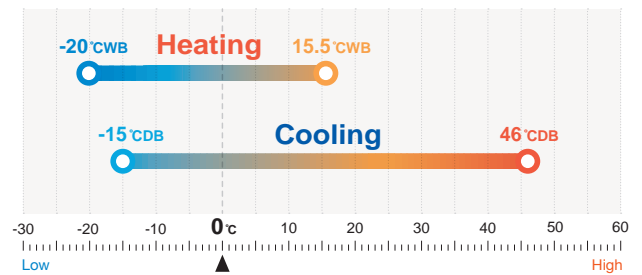

## Specifications

Item		Model	FDC280KXZA2	FDC335KXZA2
Nominal horse power			10HP	12HP
Power source			3 Phase 380-415V, 50Hz	
Starting current		A	5	
Max current		A	20.1	
Nominal capacity	Cooling	kW	28.0	33.5
	Heating	kW	31.5	37.5
Electrical characteristics	Power consumption	Cooling	7.25	8.98
		Heating	7.41	9.03
Exterior dimensions	HxWxD	mm	1697x1350x720	
Net weight		kg	284	
Sound pressure level	Cooling/Heating	dB(A)	56/57	63/62
Refrigerant	Type / GWP		R410A / 2088	
	Charge	kg/TCO2Eq	11.0 / 22.968	
Refrigerant piping size	Liquid line	mm(in)	ø9.52(3/8")	ø12.7(1/2")
	Gas line	mm(in)	ø22.22(7/8")	ø25.4(1") [ø22.22(7/8")]
Capacity connection		%	50-130	
Number of connectable indoor units			24	29

1. The data are measured under the following conditions(ISO-T1, H1). Cooling: Indoor temp. of 27°CDB, 19°CWB, and outdoor temp. of 35°CDB. Heating: Indoor temp. of 20°CDB, and outdoor temp. of 7°CDB, 6°CWB.  
 2. Sound pressure level indicates the value in an anechoic chamber. During operation these values are somewhat higher due to ambient conditions.  
 3. 'tonne(s) of CO<sub>2</sub> equivalent' means a quantity of greenhouse gases- expressed as the product of the weight of the greenhouse gases in metric tonnes and of their global warming potential.  
 4. [ ] : Pipe sizes applicable to European installations are shown in parentheses.

# Dimensions

All measurements in mm.

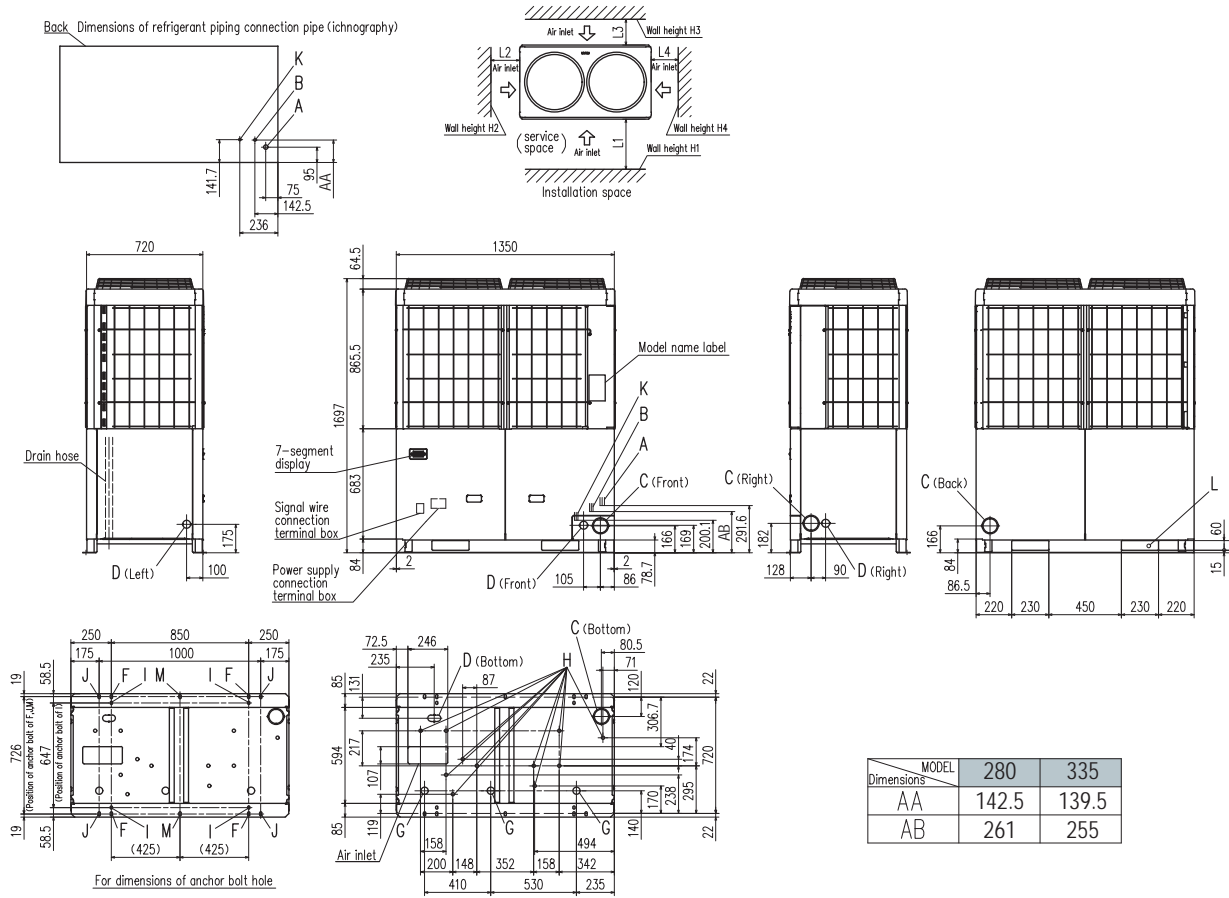

Mark	Content	280	335
A	Refrigerant gas piping connection pipe	ø22.22(Brazing)	ø25.4(Brazing)
B	Refrigerant liquid piping connection pipe	ø9.52(Flare)	ø12.7(Flare)
C	Refrigerant piping exit hole	ø88(or ø100)	
D	Power supply entry hole	ø50 (right · left · front), long hole 40 x 80 (bottom)	
F	Anchor bolt hole	M10 x 4 places	
G	Drain waste water hose hole	ø45 x 3 places	
H	Drain hole	ø20 x 11 places	
K	Refrigerant oil equalization piping connection pipe	ø9.52(Flare)	
L	Carrying in or hole for hanging	230 x 60	

Installation example		
Dimensions	1	2
L <sub>1</sub>	500	Open
L <sub>2</sub>	10(30)	10(30)
L <sub>3</sub>	100	100
L <sub>4</sub>	10(30)	Open
H <sub>1</sub>	1500	Open
H <sub>2</sub>	No limit	No limit
H <sub>3</sub>	1000	No limit
H <sub>4</sub>	No limit	Open

() .In case it is the promised installation location that the outdoor unit is used on conditions with the ambient temperature of 43°C or more.

## When more than one unit is installed

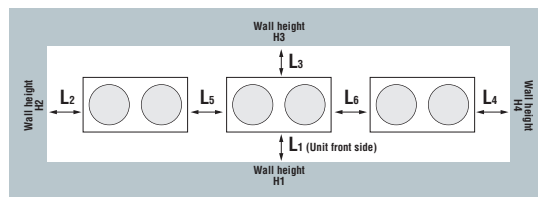

Installation example		
Dimensions	1	2
L <sub>1</sub>	500	Open
L <sub>2</sub>	10(30)	200
L <sub>3</sub>	100	300
L <sub>4</sub>	10(30)	Open
L <sub>5</sub>	10(30)	400
L <sub>6</sub>	10(30)	400
H <sub>1</sub>	1500	Open
H <sub>2</sub>	No limit	No limit
H <sub>3</sub>	1000	No limit
H <sub>4</sub>	No limit	Open

## 14-20HP (40.0kW – 56.0kW)



Model No.	Nominal Cooling Capacity
FDC400KXZA2	40.0kW
FDC450KXZA2	45.0kW
FDC475KXZA2	47.5kW
FDC500KXZA2	50.0kW
FDC560KXZA2	56.0kW

- The KXZ2 series has a layered design and a refined new form.
- Connect up to 48 indoor units/up to 130% capacity.
- High efficiency with EER up to 3.64.
- New Heating solution - Continuous Heating Capacity Control (CHCC).



Uniform footprint of all models allows continuous side-by-side installation

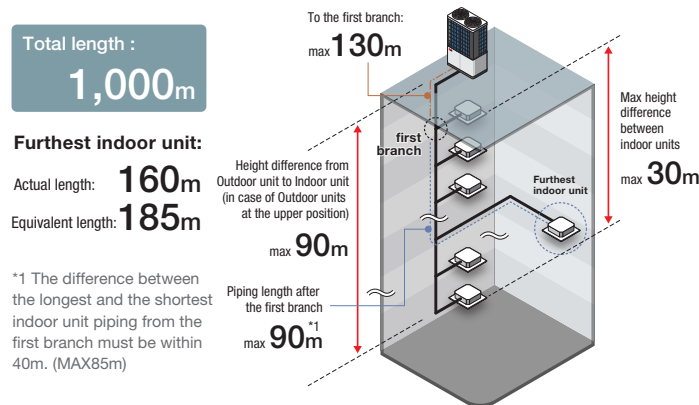

### Range of operation

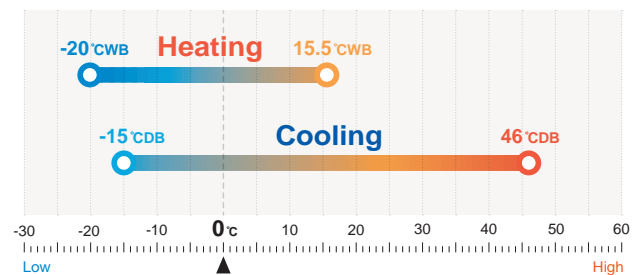

## Specifications

Item	Model	FDC400KXZA2	FDC450KXZA2	FDC475KXZA2	FDC500KXZA2	FDC560KXZA2		
Nominal horse power		14HP	16HP	17HP	18HP	20HP		
Power source		3 Phase 380-415V, 50Hz						
Starting current	A	5		8				
Max current	A	32.0		40.2				
Nominal capacity	Cooling	kW	40.0	45.0	47.5	50.0	56.0	
	Heating		45.0	50.0	53.0	56.0	63.0	
Electrical characteristics	Power consumption	kW	Cooling	10.98	13.98	13.97	14.01	17.50
			Heating	10.23	12.50	12.99	13.56	16.15
Exterior dimensions	HxWxD	mm	2052x1350x720					
Net weight		kg	328		374			
Sound pressure level	Cooling/Heating	dB(A)	60/62	61/62	61/61	61/62	63/64	
Refrigerant	Type / GWP		R410A / 2088					
	Charge	kg/TCO <sub>2</sub> Eq	11.5 / 24.012					
Refrigerant piping size	Liquid line	mm(in)	ø12.7(1/2")					
	Gas line		ø25.4(1") [ø28.58(1-1/8")]	ø28.58(1-1/8")				
Capacity connection		%	50-130					
Number of connectable indoor units			34	39	41	43	48	

1. The data are measured under the following conditions(ISO-T1, H1). Cooling: Indoor temp. of 27°CDB, 19°CWB, and outdoor temp. of 35°CDB. Heating: Indoor temp. of 20°CDB, and outdoor temp. of 7°CDB, 6°CWB.  
 2. Sound pressure level indicates the value in an anechoic chamber. During operation these values are somewhat higher due to ambient conditions.  
 3. 'tonne(s) of CO<sub>2</sub> equivalent' means a quantity of greenhouse gases- expressed as the product of the weight of the greenhouse gases in metric tonnes and of their global warming potential.  
 4. [ ] : Pipe sizes applicable to European installations are shown in parentheses.

# Dimensions

All measurements in mm.

Back Dimensions of refrigerant piping connection pipe (ichnography)

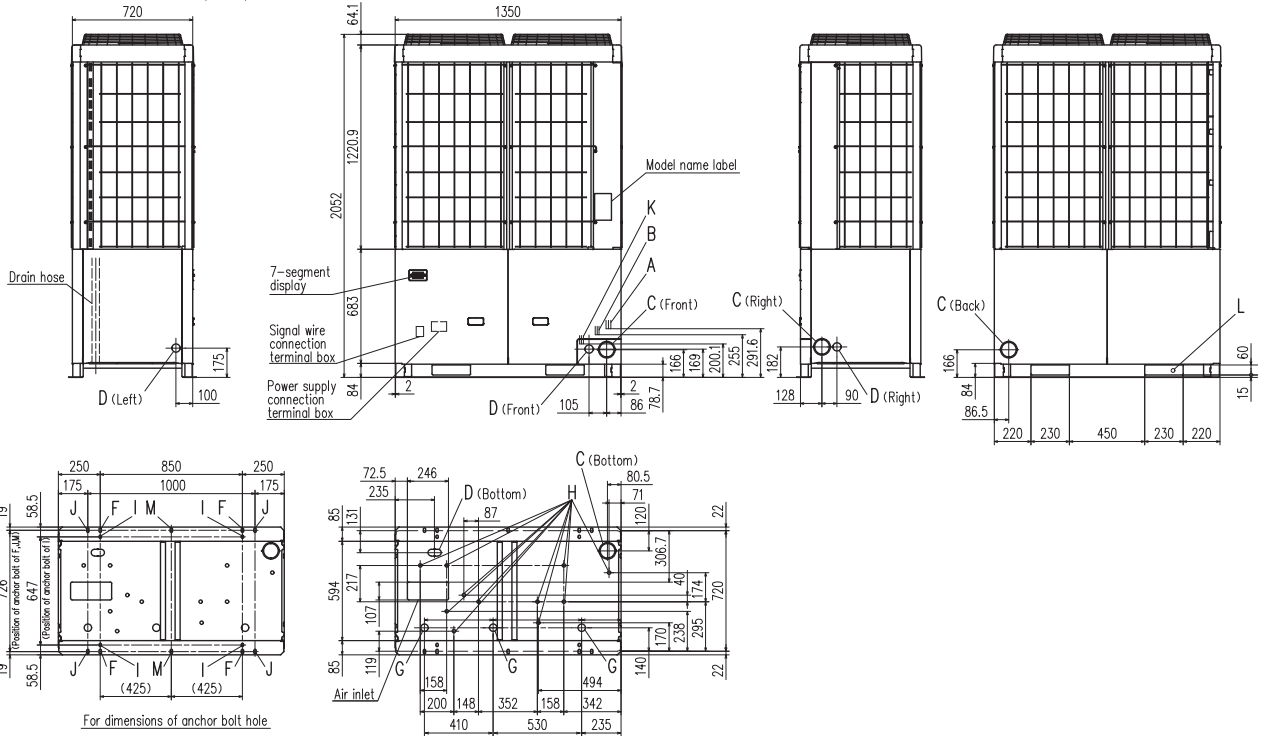
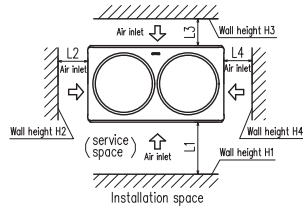
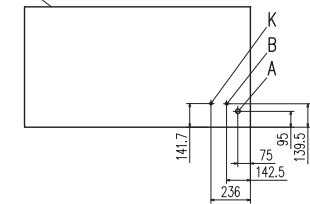

Mark	Content	400	450, 475, 500, 560
A	Refrigerant gas piping connection pipe	ø25.4(Brazing)	ø28.58(Brazing)
B	Refrigerant liquid piping connection pipe		ø12.7(Flare)
C	Refrigerant piping exit hole		ø88(or ø100)
D	Power supply entry hole	ø50 (right · left · front), long hole 40 x 80 (bottom)	
F	Anchor bolt hole	M10 x 4 places	
G	Drain waste water hose hole	ø45 x 3 places	
H	Drain hole	ø20 x 11 places	
K	Refrigerant oil equalization piping connection pipe	ø9.52(Flare)	
L	Carrying in or hole for hanging	230 x 60	

Installation example		
Dimensions	1	2
L <sub>1</sub>	500	Open
L <sub>2</sub>	10(30)	10(30)
L <sub>3</sub>	100	100
L <sub>4</sub>	10(30)	Open
H <sub>1</sub>	1500	Open
H <sub>2</sub>	No limit	No limit
H <sub>3</sub>	1000	No limit
H <sub>4</sub>	No limit	Open

(): In case it is the promised installation location that the outdoor unit is used on conditions with the ambient temperature of 43°C or more.

### When more than one unit is installed

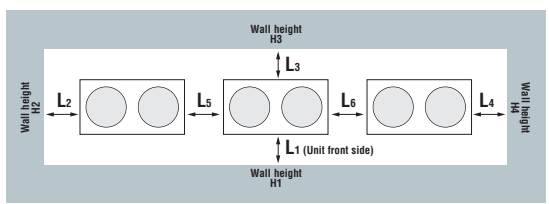

Installation example		
Dimensions	1	2
L <sub>1</sub>	500	Open
L <sub>2</sub>	10(30)	200
L <sub>3</sub>	100	300
L <sub>4</sub>	10(30)	Open
L <sub>5</sub>	10(30)	400
L <sub>6</sub>	10(30)	400
H <sub>1</sub>	1500	Open
H <sub>2</sub>	No limit	No limit
H <sub>3</sub>	1000	No limit
H <sub>4</sub>	No limit	Open



Model No.	Nominal Cooling Capacity
FDC615KXZA2	61.5kW
FDC670KXZA2	67.0kW

- The KXZ2 series has a layered design and a refined new form.
- Connect up to 58 indoor units/up to 130% capacity.
- High efficiency with EER up to 3.79.
- New Heating solution - Continuous Heating Capacity Control (CHCC).

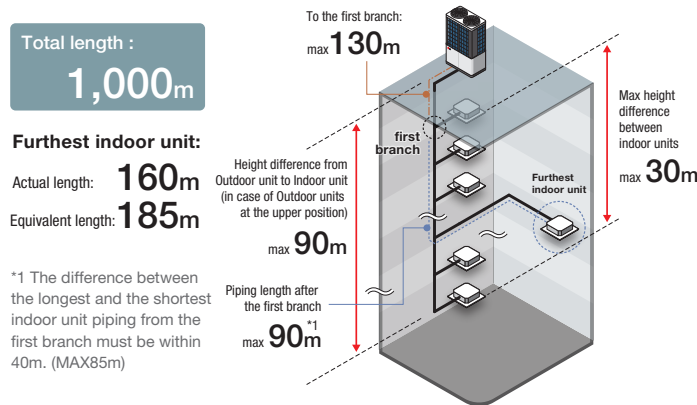

### Range of operation

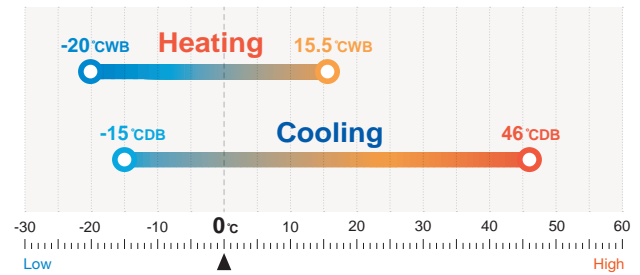

## Specifications

Exterior dimension : Please refer to page 41.

Item	Model	FDC615KXZA2	FDC670KXZA2		
Combination (FDC)		280KXZA2	335KXZA2		
		335KXZA2	335KXZA2		
Nominal horse power		22HP	24HP		
Power source		3 Phase 380-415V, 50Hz			
Starting current	A	10			
Max current	A	40.2			
Nominal capacity	Cooling	kW	61.5	67.0	
	Heating	kW	69.0	75.0	
Electrical characteristics	Power consumption	Cooling	kW	16.24	17.96
		Heating	kW	16.44	18.06
Net weight	kg	567			
Refrigerant charge	R410A	kg	11.0x2		
Refrigerant piping size	Liquid line	mm(in)	ø12.7(1/2")		
	Gas line	mm(in)	ø28.58(1-1/8")		
Capacity connection	%	50-130			
Number of connectable indoor units		53	58		

1. The data are measured under the following conditions(ISO-T1,H1). Cooling: Indoor temp. of 27°CDB, 19°CWB, and outdoor temp. of 35°CDB. Heating: Indoor temp. of 20°CDB, and outdoor temp. of 7°CDB, 6°CWB. 2.Sound pressure level indicates the value in an anechoic chamber. During operation these values are somewhat higher due to ambient conditions.

## 26-40HP (73.5kW – 112.0kW)



Model No.	Nominal Cooling Capacity
FDC735KXZA2	73.5kW
FDC800KXZA2	80.0kW
FDC850KXZA2	85.0kW
FDC900KXZA2	90.0kW
FDC950KXZA2	95.0kW
FDC1000KXZA2	100.0kW
FDC1060KXZA2	106.0kW
FDC1120KXZA2	112.0kW

- The KXZ2 series has a layered design and a refined new form.
- Connect up to 80 indoor units/up to 130% capacity.
- High efficiency with EER up to 3.68.
- New Heating solution - Continuous Heating Capacity Control (CHCC).
- Industry leading total piping length up to 1000m and a maximum height difference between indoor units has been increased to maximum of 30m.
- Wide range of operation.



FDC735



FDC800 – 1120

## Specifications

Exterior dimension : Please refer to page 41, 43.

Item		Model	FDC735KXZA2	FDC800KXZA2	FDC850KXZA2	FDC900KXZA2	FDC950KXZA2	FDC1000KXZA2	FDC1060KXZA2	FDC1120KXZA2	
Combination (FDC)			335KXZA2 400KXZA2	400KXZA2 400KXZA2	400KXZA2 450KXZA2	450KXZA2 450KXZA2	475KXZA2 475KXZA2	500KXZA2 500KXZA2	500KXZA2 560KXZA2	560KXZA2 560KXZA2	
Nominal horse power			26HP	28HP	30HP	32HP	34HP	36HP	38HP	40HP	
Power source			3 Phase 380-415V, 50Hz								
Starting current		A	10				16				
Max current		A	52.1	64.0			80.4				
Nominal capacity	Cooling	kW	73.5	80.0	85.0	90.0	95.0	100.0	106.0	112.0	
	Heating		82.5	90.0	95.0	100.0	106.0	112.0	119.0	126.0	
Electrical characteristics	Power consumption	Cooling	19.96	21.96	24.96	27.95	27.94	28.02	31.51	35.00	
		Heating	19.26	20.45	22.73	25.00	25.98	27.12	29.71	32.31	
Net weight		kg	611	655			747				
Refrigerant charge	R410A	kg	11.0+11.5	11.5x2							
Refrigerant piping size	Liquid line	mm(in)	ø15.88(5/8")						ø19.05(3/4")		
	Gas line		ø31.75(1-1/4") [ø34.92(1-3/8")]						ø38.1(1-1/2") [ø34.92(1-3/8")]		
Capacity connection		%	50-130								
Number of connectable indoor units			63	69	73	78	80				

1.The data are measured under the following conditions(ISO-T1,H1). Cooling: Indoor temp. of 27°CDB, 19°CWB, and outdoor temp. of 35°CDB. Heating: Indoor temp. of 20°CDB, and outdoor temp. of 7°CDB, 6°CWB.  
 2.Sound pressure level indicates the value in an anechoic chamber. During operation these values are somewhat higher due to ambient conditions.  
 3.[ ] : Pipe sizes applicable to European installations are shown in parentheses.

## 42-48HP (120.0kW – 135.0kW)



Model No.	Nominal Cooling Capacity
FDC1200KXZA2	120.0kW
FDC1250KXZA2	125.0kW
FDC1300KXZA2	130.0kW
FDC1350KXZA2	135.0kW

- The KXZ2 series has a layered design and a refined new form.
- Connect up to 80 indoor units/up to 130% capacity.
- High efficiency with EER up to 3.64.
- New Heating solution - Continuous Heating Capacity Control (CHCC).



Total length :  
**1,000m**

**Furthest indoor unit:**  
Actual length: **160m**  
Equivalent length: **185m**

\*1 The difference between the longest and the shortest indoor unit piping from the first branch must be within 40m. (MAX85m)

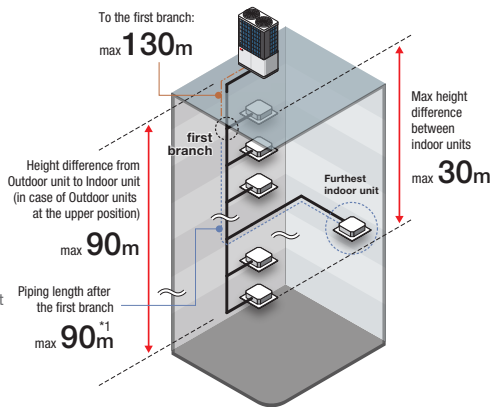

### Range of operation

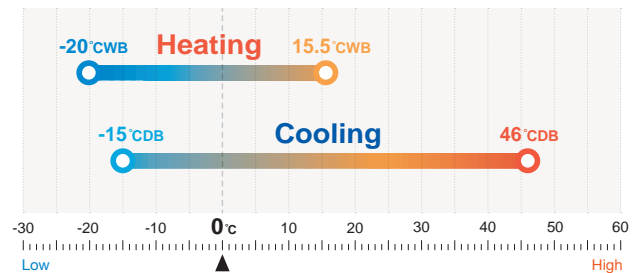

## Specifications

Exterior dimension : Please refer to page 43.

Item	Model	FDC1200KXZA2	FDC1250KXZA2	FDC1300KXZA2	FDC1350KXZA2
Combination (FDC)		400KXZA2	400KXZA2	400KXZA2	450KXZA2
		400KXZA2	400KXZA2	450KXZA2	450KXZA2
		400KXZA2	450KXZA2	450KXZA2	450KXZA2
Nominal horse power		42HP	44HP	46HP	48HP
Power source		3 Phase 380-415V, 50Hz			
Starting current	A	15			
Max current	A	96.0			
Nominal capacity	Cooling	kW			
	Heating	kW			
Electrical characteristics	Power consumption	Cooling	kW		
		Heating	kW		
Net weight	kg	982			
Refrigerant charge	R410A	kg			
Refrigerant piping size	Liquid line	mm(in)			
	Gas line	mm(in)			
Capacity connection	%	50-130			
Number of connectable indoor units		80			

1. The data are measured under the following conditions (ISO-T1,H1). Cooling: Indoor temp. of 27°CDB, 19°CWB, and outdoor temp. of 35°CDB. Heating: Indoor temp. of 20°CDB, and outdoor temp. of 7°CDB, 6°CWB.  
 2. Sound pressure level indicates the value in an anechoic chamber. During operation these values are somewhat higher due to ambient conditions.  
 3. [ ] : Pipe sizes applicable to European installations are shown in parentheses.



Model No.	Nominal Cooling Capacity
FDC1425KXZA2	142.5kW
FDC1450KXZA2	145.0kW
FDC1500KXZA2	150.0kW
FDC1560KXZA2	156.0kW
FDC1620KXZA2	162.0kW
FDC1680KXZA2	168.0kW

- The KXZ2 series has a layered design and a refined new form.
- Connect up to 80 indoor units/up to 130% capacity.
- High efficiency with EER up to 3.57.
- New Heating solution - Continuous Heating Capacity Control (CHCC).



FDC1425 – 1680

Total length :  
**1,000m**

Furthest indoor unit:  
Actual length: **160m**  
Equivalent length: **185m**

\*1 The difference between the longest and the shortest indoor unit piping from the first branch must be within 40m. (MAX35m)

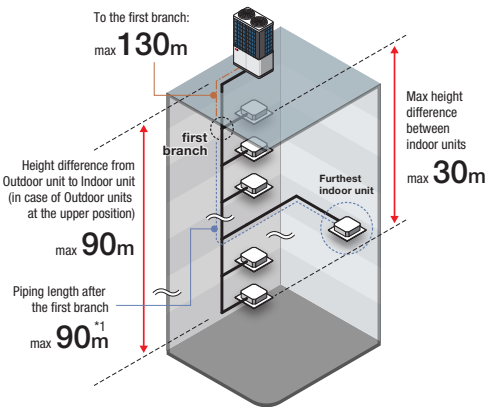

### Range of operation

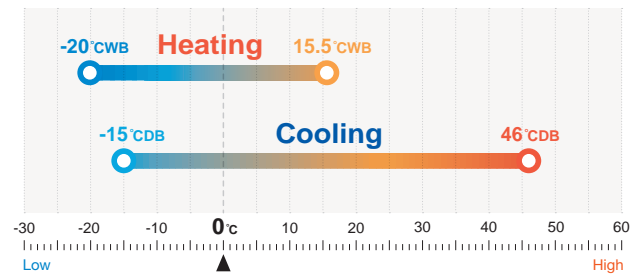

## Specifications

Exterior dimension : Please refer to page 43.

Item	Model	FDC1425KXZA2	FDC1450KXZA2	FDC1500KXZA2	FDC1560KXZA2	FDC1620KXZA2	FDC1680KXZA2	
Combination (FDC)		475KXZA2	475KXZA2	500KXZA2	500KXZA2	500KXZA2	560KXZA2	
		475KXZA2	475KXZA2	500KXZA2	500KXZA2	560KXZA2	560KXZA2	
		475KXZA2	500KXZA2	500KXZA2	560KXZA2	560KXZA2	560KXZA2	
Nominal horse power		50HP	52HP	54HP	56HP	58HP	60HP	
Power source		3 Phase 380-415V, 50Hz						
Starting current	A	24						
Max current	A	120.6						
Nominal capacity	Cooling	kW						
	Heating	kW						
Electrical characteristics	Power consumption	Cooling	kW					
		Heating	kW					
Net weight	kg	1120						
Refrigerant charge	R410A	kg						
Refrigerant piping size	Liquid line	mm(in)						
	Gas line	mm(in)						
Capacity connection	%	50-130						
Number of connectable indoor units		80						

1. The data are measured under the following conditions(ISO-T1,H1). Cooling: Indoor temp. of 27°CDB, 19°CWB, and outdoor temp. of 35°CDB. Heating: Indoor temp. of 20°CDB, and outdoor temp. of 7°CDB, 6°CWB.  
2. Sound pressure level indicates the value in an anechoic chamber. During operation these values are somewhat higher due to ambient conditions.  
3. [ ] : Pipe sizes applicable to European installations are shown in parentheses.

# KXZ<sup>2</sup> Hi-COP combination

## 20-40HP (56.0kW – 113.5kW)



### Model No.

Model No.	Configuration	Nominal Cooling Capacity
FDC560KXZA2	(FDC280+FDC280)	56.0kW
FDC850KXZA2	(FDC280+FDC280+FDC280)	84.0kW
FDC900KXZA2	(FDC280+FDC280+FDC335)	89.5kW
FDC950KXZA2	(FDC280+FDC335+FDC335)	95.0kW
FDC1000KXZA2	(FDC335+FDC335+FDC335)	100.5kW
FDC1060KXZA2	(FDC335+FDC335+FDC400)	107.0kW
FDC1120KXZA2	(FDC335+FDC400+FDC400)	113.5kW

- The KXZ2 series has a layered design and a refined new form.
- This series can connect indoor unit capacity up to 130%.
- High efficiency with EER up to 3.86.
- New Heating solution - Continuous Heating Capacity Control (CHCC).



FDC560



FDC850 - 1000



FDC1060



FDC1120

Total length :  
**1,000m**

### Furthest indoor unit:

Actual length: **160m**

Equivalent length: **185m**

\*1 The difference between the longest and the shortest indoor unit piping from the first branch must be within 40m. (MAX85m)

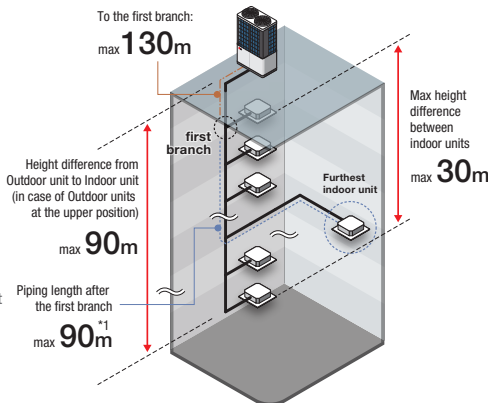

### Range of operation

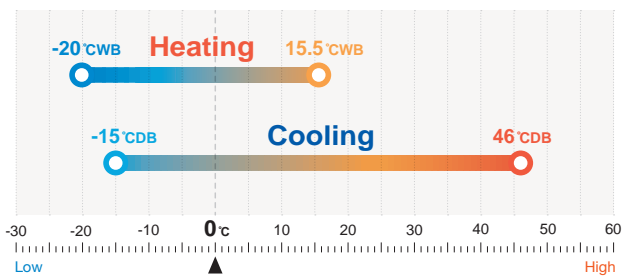

# Specifications

Item	Model		FDC560KXZA2	FDC850KXZA2	FDC900KXZA2	
Combination (FDC)			280KXZA2	280KXZA2	280KXZA2	
			280KXZA2	280KXZA2	280KXZA2	
			-	280KXZA2	335KXZA2	
Nominal horse power			20HP	30HP	32HP	
Power source			3 Phase 380-415V, 50Hz			
Starting current	A		10	15		
Max current	A		40.2	60.3		
Nominal capacity	Cooling		kW	56.0	84.0	89.5
	Heating			63.0	94.5	100.5
Electrical characteristics	Power consumption	Cooling	kW	14.51	21.76	23.49
		Heating		14.82	22.23	23.85
Net weight	kg		567	850		
Refrigerant charge	R410A	kg	11.0x2	11.0x3		
Refrigerant piping size	Liquid line	mm(in)	ø12.7(1/2")	ø15.88(5/8")		
	Gas line		ø28.58(1-1/8")	ø31.75(1-1/4") [ø34.92(1-3/8")]		
Capacity connection	%		80-130			
Number of connectable indoor units			48	73	78	

Item	Model		FDC950KXZA2	FDC1000KXZA2	FDC1060KXZA2	FDC1120KXZA2	
Combination (FDC)			280KXZA2	335KXZA2	335KXZA2	335KXZA2	
			335KXZA2	335KXZA2	335KXZA2	400KXZA2	
			335KXZA2	335KXZA2	400KXZA2	400KXZA2	
Nominal horse power			34HP	36HP	38HP	40HP	
Power source			3 Phase 380-415V, 50Hz				
Starting current	A		15				
Max current	A		60.3	72.2	84.1		
Nominal capacity	Cooling		kW	95.0	100.5	107.0	113.5
	Heating			106.5	112.5	120.0	127.5
Electrical characteristics	Power consumption	Cooling	kW	25.22	26.94	28.94	30.94
		Heating		25.47	27.09	28.29	29.48
Net weight	kg		850	894	938		
Refrigerant charge	R410A	kg	11.0x3	11.0x2+11.5	11.0+11.5x2		
Refrigerant piping size	Liquid line	mm(in)	ø15.88(5/8")		ø19.05(3/4")		
	Gas line		ø31.75(1-1/4") [ø34.92(1-3/8")]	ø38.1(1-1/2") [ø34.92(1-3/8")]			
Capacity connection	%		80-130				
Number of connectable indoor units			80				

1. The data are measured under the following conditions(ISO-T1,H1). Cooling: Indoor temp. of 27°CDB, 19°CWB, and outdoor temp. of 35°CDB. Heating: Indoor temp. of 20°CDB, and outdoor temp. of 7°CDB, 6°CWB.
2. Sound pressure level indicates the value in an anechoic chamber. During operation these values are somewhat higher due to ambient conditions.
3. [ ] : Pipe sizes applicable to European installations are shown in parentheses.

## Dimensions

Please refer to page 41, 43.

## 10-60HP (28.0kW – 168.0kW)



Model No.	Nominal Cooling Capacity	Model No.	Nominal Cooling Capacity	Model No.	Nominal Cooling Capacity
FDC280CKXZA2	28.0kW	FDC615CKXZA2	61.5kW	FDC1120CKXZA2	112.0kW
FDC335CKXZA2	33.5kW	FDC670CKXZA2	67.0kW	FDC1200CKXZA2	120.0kW
FDC400CKXZA2	40.0kW	FDC735CKXZA2	73.5kW	FDC1250CKXZA2	125.0kW
FDC450CKXZA2	45.0kW	FDC800CKXZA2	80.0kW	FDC1300CKXZA2	130.0kW
FDC475CKXZA2	47.5kW	FDC850CKXZA2	85.0kW	FDC1350CKXZA2	135.0kW
FDC500CKXZA2	50.0kW	FDC900CKXZA2	90.0kW	FDC1425CKXZA2	142.5kW
FDC560CKXZA2	56.0kW	FDC950CKXZA2	95.0kW	FDC1450CKXZA2	145.0kW
		FDC1000CKXZA2	100.0kW	FDC1500CKXZA2	150.0kW
		FDC1060CKXZA2	106.0kW	FDC1560CKXZA2	156.0kW
				FDC1620CKXZA2	162.0kW
				FDC1680CKXZA2	168.0kW

- The KXZ2 series has a layered design and a refined new form.
- Connect up to 80 indoor units/up to 130% capacity.
- High efficiency with EER up to 3.86.
- Industry leading total piping length up to 1000m and a maximum pipe run of 160m.



FDC280CKXZA2  
FDC335CKXZA2



FDC400CKXZA2  
FDC450CKXZA2  
FDC475CKXZA2  
FDC500CKXZA2  
FDC560CKXZA2

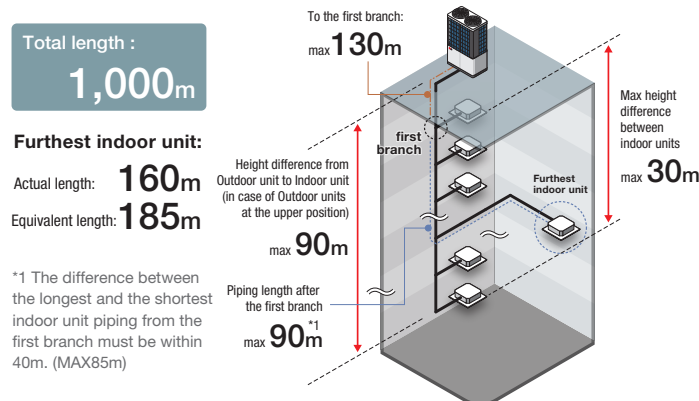

### Range of operation

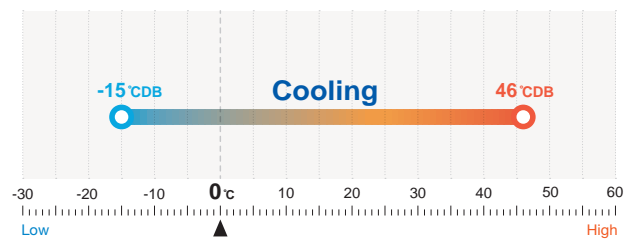

# Specifications

Item		Model	FDC280CKXZA2		FDC335CKXZA2	
Nominal horse power			10HP		12HP	
Power source			3 Phase 380-415V, 50Hz			
Starting current		A	5			
Max current		A	20.1			
Nominal capacity	Cooling	kW	28.0		33.5	
Electrical characteristics	Power consumption	Cooling kW	7.25		8.98	
Net weight		kg	284			
Sound pressure level		Cooling dB(A)	56		63	
Refrigerant		Type / GWP	R410A / 2088			
		Charge	kg/TCO <sub>2</sub> Eq 11.0 / 22.968			
Refrigerant piping size		Liquid line	ø9.52(3/8")		ø12.7(1/2")	
		Gas line	ø22.22(7/8")		ø25.4(1") [ø22.22(7/8")]	
Capacity connection		%	50-130			
Number of connectable indoor units			24		29	

Item		Model	FDC400CKXZA2	FDC450CKXZA2	FDC475CKXZA2	FDC500CKXZA2	FDC560CKXZA2
Nominal horse power			14HP	16HP	17HP	18HP	20HP
Power source			3 Phase 380-415V, 50Hz				
Starting current		A	5			8	
Max current		A	32.0			40.2	
Nominal capacity	Cooling	kW	40.0	45.0	47.5	50.0	56.0
Electrical characteristics	Power consumption	Cooling kW	10.98	13.98	13.97	14.01	17.50
Net weight		kg	328			374	
Sound pressure level		Cooling dB(A)	60	61	61	61	63
Refrigerant		Type / GWP	R410A / 2088				
		Charge	kg/TCO <sub>2</sub> Eq 11.5 / 24.012				
Refrigerant piping size		Liquid line	ø12.7(1/2")				
		Gas line	ø25.4(1") [ø28.58(1-1/8")]		ø28.58(1-1/8")		
Capacity connection		%	50-130				
Number of connectable indoor units			34	39	41	43	48

Item		Model	FDC615CKXZA2	FDC670CKXZA2	FDC735CKXZA2	FDC800CKXZA2	FDC850CKXZA2
Combination (FDC)			280CKXZA2	335CKXZA2	335CKXZA2	400CKXZA2	400CKXZA2
			335CKXZA2	335CKXZA2	400CKXZA2	400CKXZA2	450CKXZA2
Nominal horse power			22HP	24HP	26HP	28HP	30HP
Power source			3 Phase 380-415V, 50Hz				
Starting current		A	10				
Max current		A	40.2		52.1	64.0	
Nominal capacity	Cooling	kW	61.5	67.0	73.5	80.0	85.0
Electrical characteristics	Power consumption	Cooling kW	16.24	17.96	19.96	21.96	24.96
Net weight		kg	567		611	655	
Refrigerant charge		R410A kg	11.0x2		11.0+11.5		
Refrigerant piping size		Liquid line	ø12.7(1/2")		ø15.88(5/8")		
		Gas line	ø28.58(1-1/8")		ø31.75(1-1/4") [ø34.92(1-3/8")]		
Capacity connection		%	50-130				
Number of connectable indoor units			53	58	63	69	73

1. The data are measured under the following conditions (ISO-T1). Cooling: Indoor temp. of 27°CDB, 19°CWB, and outdoor temp. of 35°CDB.

2. Sound pressure level indicates the value in an anechoic chamber. During operation these values are somewhat higher due to ambient conditions.

3. 'tonne(s) of CO<sub>2</sub> equivalent' means a quantity of greenhouse gases- expressed as the product of the weight of the greenhouse gases in metric tonnes and of their global warming potential.

4. [ ] : Pipe sizes applicable to European installations are shown in parentheses.

# Specifications

Item	Model	FDC900CKXZA2	FDC950CKXZA2	FDC1000CKXZA2	FDC1060CKXZA2	FDC1120CKXZA2		
Combination (FDC)		450CKXZA2	475CKXZA2	500CKXZA2	500CKXZA2	560CKXZA2		
		450CKXZA2	475CKXZA2	500CKXZA2	560CKXZA2	560CKXZA2		
Nominal horse power		32HP	34HP	36HP	38HP	40HP		
Power source		3 Phase 380-415V, 50Hz						
Starting current	A	10	16					
Max current	A	64.0	80.4					
Nominal capacity	Cooling	kW	90.0	95.0	100.0	106.0	112.0	
Electrical characteristics	Power consumption	Cooling	kW	27.95	27.94	28.02	31.51	35.00
Net weight		kg	655	747				
Refrigerant charge	R410A	kg	11.5x2					
Refrigerant piping size	Liquid line	mm(in)	ø15.88(5/8")			ø19.05(3/4")		
	Gas line		ø31.75(1-1/4") [ø34.92(1-3/8")]			ø38.1(1-1/2") [ø34.92(1-3/8")]		
Capacity connection		%	50-130					
Number of connectable indoor units			78	80				

Item	Model	FDC1200CKXZA2	FDC1250CKXZA2	FDC1300CKXZA2	FDC1350CKXZA2	FDC1425CKXZA2		
Combination (FDC)		400CKXZA2	400CKXZA2	400CKXZA2	450CKXZA2	475CKXZA2		
		400CKXZA2	400CKXZA2	450CKXZA2	450CKXZA2	475CKXZA2		
		400CKXZA2	450CKXZA2	450CKXZA2	450CKXZA2	475CKXZA2		
Nominal horse power		42HP	44HP	46HP	48HP	50HP		
Power source		3 Phase 380-415V, 50Hz						
Starting current	A	15				24		
Max current	A	96.0				120.6		
Nominal capacity	Cooling	kW	120.0	125.0	130.0	135.0	142.5	
Electrical characteristics	Power consumption	Cooling	kW	32.94	35.94	38.93	41.93	41.91
Net weight		kg	982			1120		
Refrigerant charge	R410A	kg	11.5x3					
Refrigerant piping size	Liquid line	mm(in)	ø19.05(3/4")					
	Gas line		ø38.1(1-1/2") [ø34.92(1-3/8")]					
Capacity connection		%	50-130					
Number of connectable indoor units			80					

Item	Model	FDC1450CKXZA2	FDC1500CKXZA2	FDC1560CKXZA2	FDC1620CKXZA2	FDC1680CKXZA2		
Combination (FDC)		475CKXZA2	500CKXZA2	500CKXZA2	500CKXZA2	560CKXZA2		
		475CKXZA2	500CKXZA2	500CKXZA2	560CKXZA2	560CKXZA2		
		500CKXZA2	500CKXZA2	560CKXZA2	560CKXZA2	560CKXZA2		
Nominal horse power		52HP	54HP	56HP	58HP	60HP		
Power source		3 Phase 380-415V, 50Hz						
Starting current	A	24						
Max current	A	120.6						
Nominal capacity	Cooling	kW	145.0	150.0	156.0	162.0	168.0	
Electrical characteristics	Power consumption	Cooling	kW	41.95	42.03	45.52	49.01	52.50
Net weight		kg	1120					
Refrigerant charge	R410A	kg	11.5x3					
Refrigerant piping size	Liquid line	mm(in)	ø19.05(3/4")					
	Gas line		ø38.1(1-1/2") [ø34.92(1-3/8")]					
Capacity connection		%	50-130					
Number of connectable indoor units			80					

- The data are measured under the following conditions (ISO-T1). Cooling: Indoor temp. of 27°CDB, 19°CWB, and outdoor temp. of 35°CDB.
- Sound pressure level indicates the value in an anechoic chamber. During operation these values are somewhat higher due to ambient conditions.
- [ ] : Pipe sizes applicable to European installations are shown in parentheses.

## Dimensions

Please refer to page 41, 43.

# 20-40HP (56.0kW – 113.5kW)



### Model No.

FDC560CKXZA2	(FDC280+FDC280)	56.0kW
FDC850CKXZA2	(FDC280+FDC280+FDC280)	84.0kW
FDC900CKXZA2	(FDC280+FDC280+FDC335)	89.5kW
FDC950CKXZA2	(FDC280+FDC335+FDC335)	95.0kW
FDC1000CKXZA2	(FDC335+FDC335+FDC335)	100.5kW
FDC1060CKXZA2	(FDC335+FDC335+FDC400)	107.0kW
FDC1120CKXZA2	(FDC335+FDC400+FDC400)	113.5kW

### Nominal Cooling Capacity



**FDC1060**

(combination example)

Higher Economic Benefits

High Efficiency

Higher Energy Savings

## Specifications

Item	Model	FDC560CKXZA2	FDC850CKXZA2	FDC900CKXZA2		
Combination (FDC)		280CKXZA2	280CKXZA2	280CKXZA2		
		280CKXZA2	280CKXZA2	280CKXZA2		
		-	280CKXZA2	335CKXZA2		
Nominal horse power		20HP	30HP	32HP		
Power source		3 Phase 380-415V, 50Hz				
Starting current	A	10	15			
Max current	A	40.2	60.3			
Nominal capacity	Cooling	kW	56.0	84.0	89.5	
Electrical characteristics	Power consumption	Cooling	kW	14.51	21.76	23.49
Net weight		kg	567	850		
Refrigerant charge	R410A	kg	11.0x2	11.0x3		
Refrigerant piping size	Liquid line	mm(in)	ø12.7(1/2")			
	Gas line		ø28.58(1-1/8")			
Capacity connection		%	80-130			
			80-130			
Number of connectable indoor units			48	73	78	

Item	Model	FDC950CKXZA2	FDC1000CKXZA2	FDC1060CKXZA2	FDC1120CKXZA2		
Combination (FDC)		280CKXZA2	335CKXZA2	335CKXZA2	335CKXZA2		
		335CKXZA2	335CKXZA2	335CKXZA2	400CKXZA2		
		335CKXZA2	335CKXZA2	400CKXZA2	400CKXZA2		
Nominal horse power		34HP	36HP	38HP	40HP		
Power source		3 Phase 380-415V, 50Hz					
Starting current	A	15					
Max current	A	60.3		72.2	84.1		
Nominal capacity	Cooling	kW	95.0	100.5	107.0	113.5	
Electrical characteristics	Power consumption	Cooling	kW	25.22	26.94	28.94	30.94
Net weight		kg	850		894	938	
Refrigerant charge	R410A	kg	11.0x3	11.0x2+11.5	11.0+11.5x2		
Refrigerant piping size	Liquid line	mm(in)	ø15.88(5/8")		ø19.05(3/4")		
	Gas line		ø31.75(1-1/4") [ø34.92(1-3/8")]		ø38.1(1-1/2") [ø34.92(1-3/8")]		
Capacity connection		%	80-130				
			80-130				
Number of connectable indoor units			80				

1. The data are measured under the following conditions(ISO-T1). Cooling: Indoor temp. of 27°CDB, 19°CWB, and outdoor temp. of 35°CDB.  
 2. Sound pressure level indicates the value in an anechoic chamber. During operation these values are somewhat higher due to ambient conditions.  
 3. [ ] : Pipe sizes applicable to European installations are shown in parentheses.

## Dimensions

Please refer to page 41, 43.

## Corrosion Protection Treatment series

# 4-60HP (11.2kW – 168.0kW)



Production by order

Corrosion Protection Treatment series are available with special coating applied for not only sheet metals but also small parts in order to prevent salt corrosion caused by sea breeze in area along coast line (Within approximately 500m from coast line).

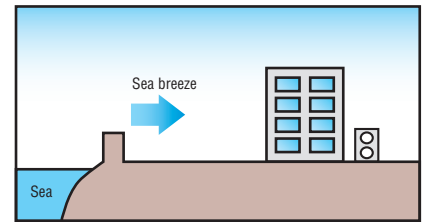

Model No.	Nominal Cooling Capacity	Model No.	Nominal Cooling Capacity	Model No.	Nominal Cooling Capacity
FDCS112KXEN6	11.2kW	FDCS280KXZA2	28.0kW	FDCS280CKXZA2	28.0kW
FDCS112KXES6	11.2kW	FDCS335KXZA2	33.5kW	FDCS335CKXZA2	33.5kW
FDCS140KXEN6	14.0kW	FDCS400KXZA2	40.0kW	FDCS400CKXZA2	40.0kW
FDCS140KXES6	14.0kW	FDCS450KXZA2	45.0kW	FDCS450CKXZA2	45.0kW
FDCS155KXEN6	15.5kW	FDCS475KXZA2	47.5kW	FDCS475CKXZA2	47.5kW
FDCS155KXES6	15.5kW	FDCS500KXZA2	50.0kW	FDCS500CKXZA2	50.0kW
FDCS224KXE6G	22.4kW	FDCS560KXZA2	56.0kW	FDCS560CKXZA2	56.0kW
FDCS280KXE6G	28.0kW				
FDCS335KXE6G	33.5kW				

- Combination systems:22-60HP (61.5kW-168.0kW) are the same as that of the standard KXZA2/CKXZA2 series shown on previous pages.
- Specifications and Dimensions are the same as that of the standard KXZA2 series shown on previous pages.
- Non-CE Marking models.



## Corrosion resistance performance of high anticorrosion fin

### Comparison of weight loss by corrosion

#### Neutral salt water spray test

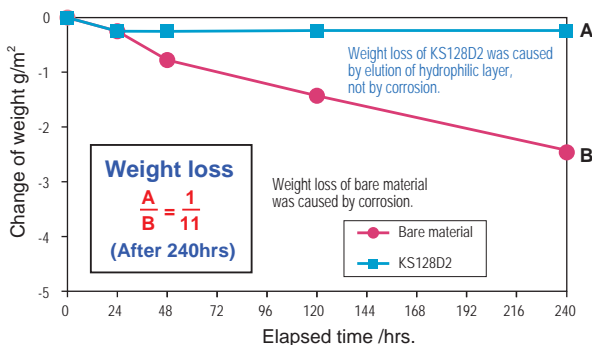

#### <Test conditions>

JIS Z2371  
NaCl concentration : 50g/L  
pH : 6.5-7.2  
temperature : 35°C

#### Acetic acid salt water spray test

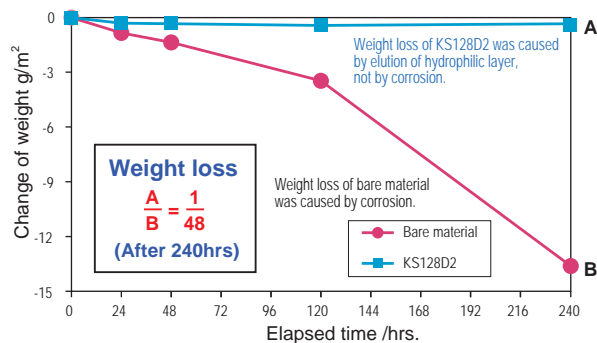

#### <Test conditions>

JIS Z2371  
NaCl concentration : 50g/L  
pH : 3.1-3.3 (adjusted with acetic acid)  
temperature : 35°C

## Appearance comparison before and after acetic acid salt water spray test

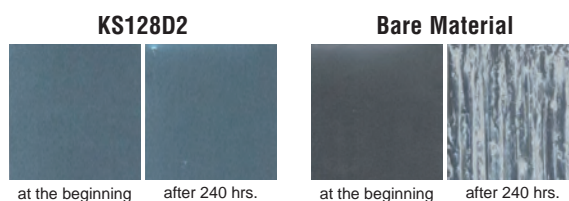

For outside sheet metals, Cation electrodeposition coating is used for undercoat plus polyester powder coating or acrylic baked coating for top coat and corrosion protection is applied for heat exchanger, welded parts, fan guard, fin guard and other major parts.

Preventing corrosion by salt damage or sulfurous acid gas has made service life of this series longer while its exterior appearance has been greatly improved.

Durability of this series for anticorrosion is about two times that of standard outdoor units under the same conditions.

## Additional treatment from the standard series

		Micro KX	KXZA2
Exterior panel		undercoat: Cation electrodeposition coating topcoat: polyester powder coating or acrylic baked coating	undercoat: Cation electrodeposition coating topcoat: acrylic baked coating
Base plate		undercoat: Cation electrodeposition coating topcoat: polyester powder coating or acrylic baked coating	undercoat: Cation electrodeposition coating topcoat: acrylic baked coating
Drain pan		_____	undercoat: Cation electrodeposition coating topcoat: acrylic baked coating
Fan motor		application of anticorrosion compound	application of anticorrosion compound
Fan motor base		4-6HP _____	application of anticorrosion compound
		8-12HP application of anticorrosion compound	
Heat exchanger	Fin	Precoated Aluminum Blue Fins in high anticorrosion specification	Precoated Aluminum Blue Fins in high anticorrosion specification
	pipe	application of anticorrosion compound	application of anticorrosion compound
	Side plate	application of anticorrosion compound	application of anticorrosion compound
Compressor		application of anticorrosion compound	application of anticorrosion compound
Accumulator		application of anticorrosion compound	application of anticorrosion compound
Receiver		application of anticorrosion compound	application of anticorrosion compound
Control box		4-6HP _____	galvanized steel sheet + undercoat: Cation electrodeposition coating + topcoat: acrylic baked finish
		8-12HP application of anticorrosion compound	
Baffle plate		4-6HP _____	_____
		8-12HP application of anticorrosion compound	
Service valve bracket		4-6HP _____	galvanized steel sheet + undercoat: Cation electrodeposition coating + topcoat: acrylic baking finish
		8-12HP application of anticorrosion compound	
Screw for exterior panel		zinc coating + chromate treatment + fluorine coating	zinc coating + chromate treatment + fluorine coating
Screw tap for inside of exterior panel		zinc coating + chromate treatment + fluorine coating	zinc coating + chromate treatment + fluorine coating

Corrosion protection treatment complies with regulation of The Japan Refrigeration and Air Conditioning Industry Association (JRA9002)

## Caution

Even if the outdoor unit is protected with the anti-salt damage treatment, it cannot be perfectly free from rusting.

The following points should be kept in mind during installation and maintenance of the outdoor units.

### Installation

- (1) When installing the outdoor unit close to the coastal area, provide a windbreak to protect it from direct sea breeze and salt water splash.
- (2) Select a well-drained place to install.
- (3) If any scratch or damages occurred on the outdoor unit during installation, repair it carefully.

### Maintenance

- (1) Clean salt grains on the outdoor unit with fresh water periodically.
- (2) Apply rust preventive at regular intervals for maintenance depending on the conditions at the installation place (consulting with the withstanding capacity).
- (3) Confirm reset of screw tap after maintenance, if missing it may cause corrosion occurred from the hole of screw tap.
- (4) During prolonged non operation periods, protect the unit with covering.

## 8-36HP (22.4kW – 100.0kW)



Production by order

Model No.	Nominal Cooling Capacity	Model No.	Nominal Cooling Capacity
FDC224KXZWE1	22.4kW	FDC730KXZWE1(FDC224×2+FDC280)	73.0kW
FDC280KXZWE1	28.0kW	FDC775KXZWE1(FDC224+FDC280×2)	77.5kW
FDC335KXZWE1	33.5kW	FDC850KXZWE1(FDC280×3)	85.0kW
FDC450KXZWE1(FDC224×2)	45.0kW	FDC900KXZWE1(FDC280×2+FDC335)	90.0kW
FDC500KXZWE1(FDC224+FDC280)	50.0kW	FDC950KXZWE1(FDC280+FDC335×2)	95.0kW
FDC560KXZWE1(FDC280×2)	56.0kW	FDC1000KXZWE1(FDC335×3)	100.0kW
FDC615KXZWE1(FDC280+FDC335)	61.5kW		
FDC670KXZWE1(FDC335×2)	67.0kW		

### Features

#### 1. High efficiency (EER/COP)

- Energy saving → Reduction of operation cost

#### 2. Compact design

- Easy transportation and installation
- Carriable by elevator

#### 3. BMS (Building Management System)

- Can use the same BMS as air cooled KX
- Available to large-scale and fine control

#### 4. Serviceability & Maintenance

- Service and maintenance of main parts can be done from the front side only
- Useful service tools (Mente-PC, SL-Checker etc.)

### Applicable to

#### 1. High-rise Building

- 50m <FDC> , -100m <FDCH>
- 100m or higher in height <FDCW>

#### 2. Glass-exterior facade Building

- Possible to hide KXZW units and to keep fine sight



### Specifications

Item	Model	FDC224KXZWE1	FDC280KXZWE1	FDC335KXZWE1	FDC450KXZWE1	FDC500KXZWE1	FDC560KXZWE1	FDC615KXZWE1	FDC670KXZWE1
Combination (FDC)		-	-	-	224KXZWE1	224KXZWE1	280KXZWE1	280KXZWE1	335KXZWE1
Nominal horse power		8HP	10HP	12HP	16HP	18HP	20HP	22HP	24HP
Power source		3 Phase 380-415V, 50Hz							
Nominal capacity	Cooling	22.4	28.0	33.5	45.0	50.0	56.0	61.5	67.0
	Heating	25.0	31.5	37.5	50.0	56.0	63.0	69.0	75.0
Power consumption	Cooling	4.23	5.75	8.13	8.49	9.83	11.5	13.7	16.3
	Heating	4.24	5.10	6.30	8.47	9.27	10.2	11.4	12.6
EER	Cooling	5.3	4.9	4.1	5.3	5.1	4.9	4.5	4.1
COP	Heating	5.9	6.2	6.0	5.9	6.0	6.2	6.1	6.0
Exterior dimensions	HxWxD	1100x780x550			-				
Sound pressure level	dB(A)	48	50	52	51	52	53	54	55
Net weight	kg	185			185x2				

Item	Model	FDC730KXZWE1	FDC775KXZWE1	FDC850KXZWE1	FDC900KXZWE1	FDC950KXZWE1	FDC1000KXZWE1
Combination (FDC)		224KXZWE1	224KXZWE1	280KXZWE1	280KXZWE1	280KXZWE1	335KXZWE1
Nominal horse power		26HP	28HP	30HP	32HP	34HP	36HP
Power source		3 Phase 380-415V, 50Hz					
Nominal capacity	Cooling	73.0	77.5	85.0	90.0	95.0	100
	Heating	82.5	90.0	95.0	100	106	112
Power consumption	Cooling	14.2	15.5	17.5	19.5	21.7	24.3
	Heating	13.8	14.8	15.4	16.4	17.6	18.8
EER	Cooling	5.1	5.0	4.9	4.6	4.4	4.1
COP	Heating	6.0	6.1	6.2	6.1	6.0	6.0
Exterior dimensions	HxWxD	-					
Sound pressure level	dB(A)	54	54	55	56	56	57
Net weight	kg	185x3					

The data are measured at the following condition:  
 Cooling: Indoor temp. of 27 °C DB, 19 °C WB, and heat source unit inlet water temp. of 30 °C, water flow rate 96 L/min  
 Heating: Indoor temp. of 20 °C DB, 15 °C WB, and heat source unit inlet water temp. of 20 °C, water flow rate 96 L/min

Heat source units on every floor  
- New building projects -

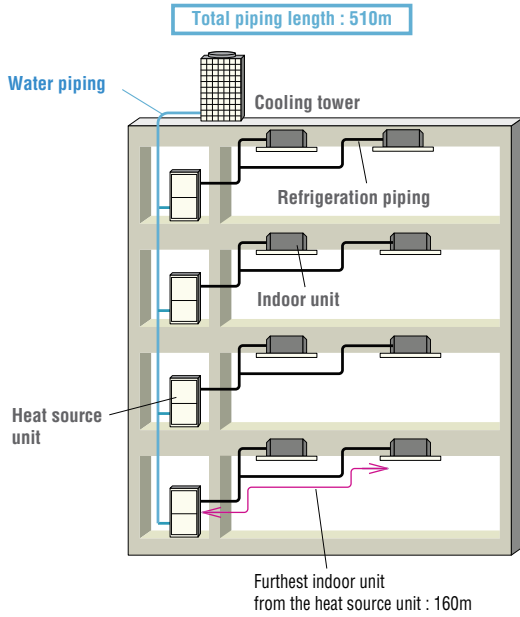

Heat source units in the machine room  
- Renovation projects -

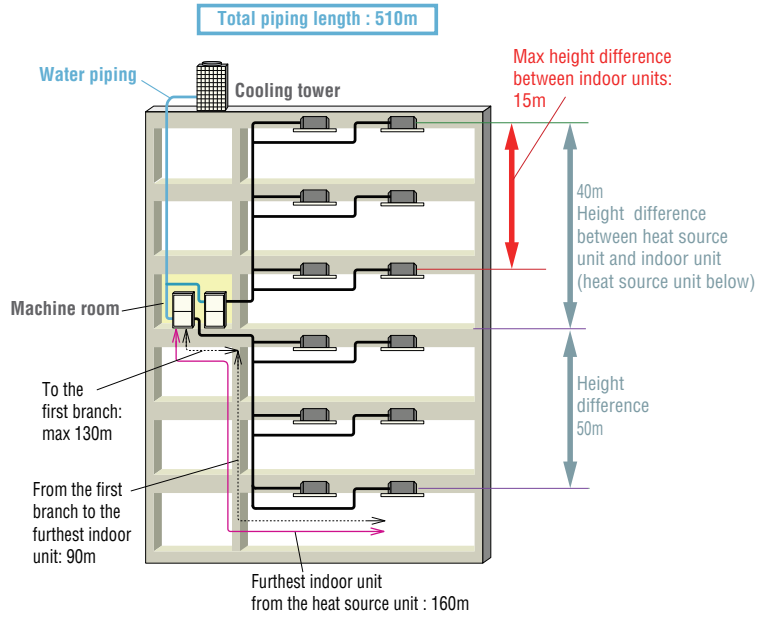

## Dimensions

All measurements in mm.

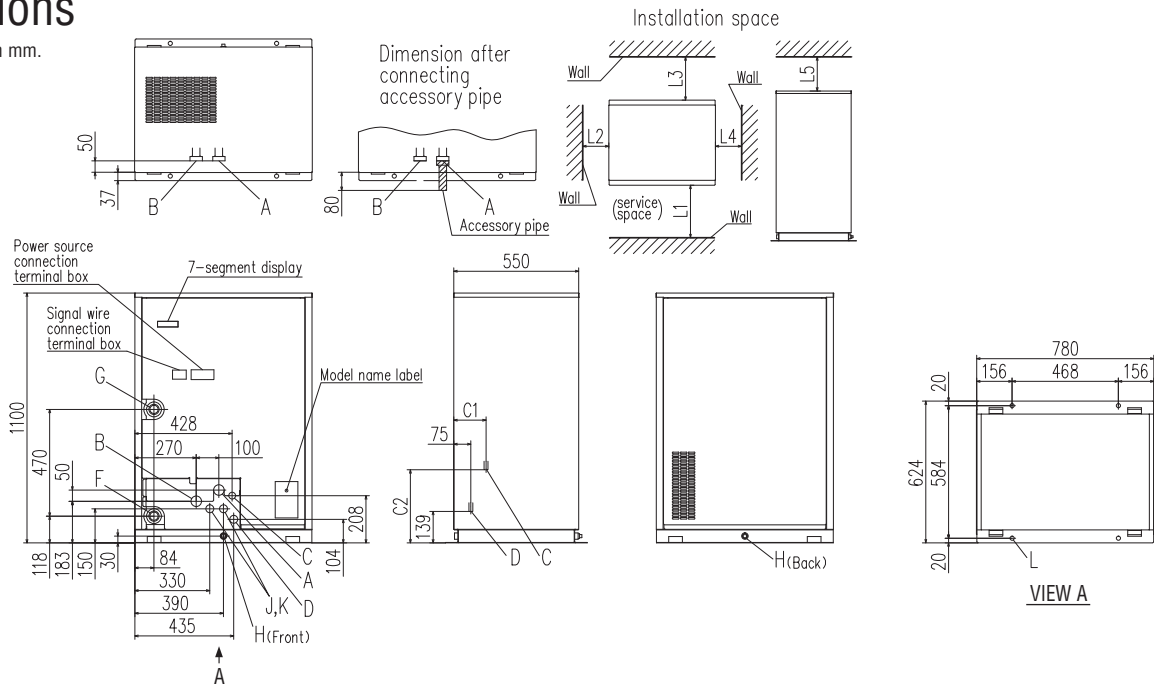

Mark	Content	
A	High/low gas line	Refer to piping size
B	-	Not to use.
C	Liquid line	Refer to piping size
D	Oil equalization line	
F	Water inlet	R1 1/4
G	Water outlet	R1 1/4
H	Drain outlet	Rp 1/2, 2places
J	Power source intake	ø35
K	Signal wiring intake	ø35
L	Anchor bolt hole	ø18, 4places

Dimension	FDC-KXZWE1
	224, 280 335
C1	142 139
C2	322 316
Dimension	Installation example 1
L1	600 or more
L2	20 or more
L3	500 or more
L4	20 or more
L5	300 or more

### Piping size

	FDC224KXZWE1	FDC280KXZWE1	FDC335KXZWE1	Connection method
High/low gas line	ø19.05	ø22.22	ø25.4	Flange
Liquid line	ø9.52	ø9.52	ø12.7	Flare
Oil equalization line	ø9.52	ø9.52	ø9.52	

## 14-48HP (40.0kW – 136.0kW)



Production by order

Model No.	Nominal Cooling Capacity
FDCH335CKXE6G-K <sup>※</sup>	33.5 kW(380V)
FDCH400CKXE6G	40.0 kW(380V)
FDCH450CKXE6G	45.0 kW(380V)
FDCH504CKXE6G	50.4 kW(380V)
FDCH560CKXE6G	56.0 kW(380V)
FDCH560CKXE6G-K <sup>※</sup>	56.0 kW(380V)
FDCH615CKXE6G	61.5 kW(380V)
FDCH680CKXE6G	68.0 kW(380V)

※ FDCH335CKXE6G-K & FDCH560CKXE6G-K are only used for combining with other models.

- Maximum allowable height difference between the outdoor and the indoor unit located at the lowest height position has been increased from 50m to 100m.  
(When the outdoor unit is located at higher position than the indoor unit)
- Non-CE Marking models.

Model No.	Nominal Cooling Capacity
FDCH735CKXE6G (FDCH335-K+FDCH400)	73.5 kW(380V)
FDCH800CKXE6G (FDCH400x2)	80.0 kW(380V)
FDCH850CKXE6G (FDCH400+FDCH450)	85.0 kW(380V)
FDCH900CKXE6G (FDCH450x2)	90.0 kW(380V)
FDCH960CKXE6G (FDCH450+FDCH504)	96.0 kW(380V)
FDCH1010CKXE6G (FDCH504x2)	101.0 kW(380V)
FDCH1065CKXE6G (FDCH504+FDCH560)	106.5 kW(380V)
FDCH1130CKXE6G (FDCH560x2)	113.0 kW(380V)
FDCH1180CKXE6G (FDCH560-K+FDCH615)	118.0 kW(380V)
FDCH1235CKXE6G (FDCH615x2)	123.5 kW(380V)
FDCH1300CKXE6G (FDCH615+FDCH680)	130.0 kW(380V)
FDCH1360CKXE6G (FDCH680x2)	136.0 kW(380V)



FDCH335CKXE6G-K  
FDCH400CKXE6G  
FDCH450CKXE6G



FDCH504-680CKXE6G

Total length :  
**1,000m**

Furthest indoor unit:  
Actual length: **160m**  
Equivalent length: **185m**

\*1 The difference between the longest and the shortest indoor unit piping from the first branch must be within 40m.

\*2 In case of less than 50m, the High Head models can not be applied.  
In case Indoor unit is higher than outdoor unit, the High Head models can not be applied.

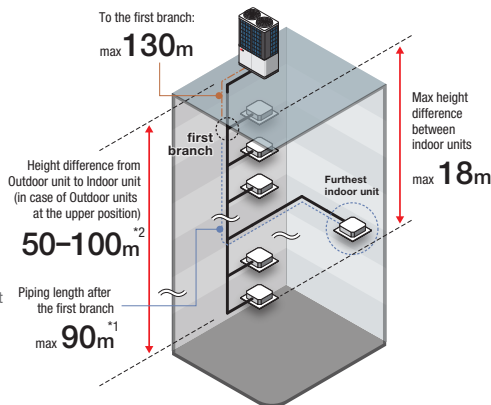

### Range of operation

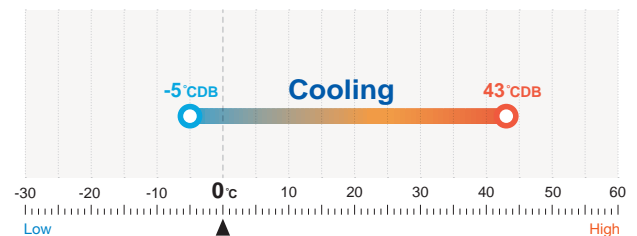

# Specifications

Item	Model	FDCH400CKXE6G	FDCH450CKXE6G	FDCH504CKXE6G	FDCH560CKXE6G	FDCH615CKXE6G	FDCH680CKXE6G		
Nominal horse power		14HP	16HP	18HP	20HP	22HP	24HP		
Power source		3 Phase 380V, 60Hz							
Starting current	A	8							
Max current	A	47							
Nominal capacity	Cooling	kW	40.0	45.0	50.4	56.0	61.5	68.0	
Electrical characteristics	Power consumption	Cooling	kW	11.27	12.97	14.73	16.79	20.37	24.98
Exterior dimensions	HxWxD	mm	1690x1350x720			2048x1350x720			
Net weight		kg	326		358		377		
Sound pressure level	Cooling	dB(A)	59.5	62.5	61.5	63.0	64.5	65.0	
Refrigerant	Type/GWP		R410A/2088						
	Charge	kg/TCO <sub>2</sub> Eq	11.5/24.012						
Refrigerant piping size	Liquid line	mm(in)	ø12.7(1/2")			ø15.88(5/8")			
	Gas line	mm(in)	ø25.4(1") [ø28.58(1.1/8")]	ø28.58(1.1/8")		ø28.58(1.1/8")			
Capacity connection		%	50-200			50-160			
Number of connectable indoor units			36	40	36	40	44	49	

Item	Model	FDCH735CKXE6G	FDCH800CKXE6G	FDCH850CKXE6G	FDCH900CKXE6G		
Combination (FDCH)		335CKXE6G-K	400CKXE6G	400CKXE6G	450CKXE6G		
		400CKXE6G	400CKXE6G	450CKXE6G	450CKXE6G		
Nominal horse power		26HP	28HP	30HP	32HP		
Power source		3 Phase 380V, 60Hz					
Starting current	A	16					
Max current	A	94					
Nominal capacity	Cooling	kW	73.5	80.0	85.0	90.0	
Electrical characteristics	Power consumption	Cooling	kW	20.21	22.54	24.24	25.94
Net weight		kg	326x2				
Refrigerant charge	R410A	kg	11.5x2				
Refrigerant piping size	Liquid line	mm(in)	ø19.05(3/4")				
	Gas line	mm(in)	ø31.8(1.1/4") [ø34.92(1.3/8")]				
Capacity connection		%	50-160				
Number of connectable indoor units			53	58	61	65	

Item	Model	FDCH960CKXE6G	FDCH1010CKXE6G	FDCH1065CKXE6G	FDCH1130CKXE6G		
Combination (FDCH)		450CKXE6G	504CKXE6G	504CKXE6G	560CKXE6G		
		504CKXE6G	504CKXE6G	560CKXE6G	560CKXE6G		
Nominal horse power		34HP	36HP	38HP	40HP		
Power source		3 Phase 380V, 60Hz					
Starting current	A	16					
Max current	A	94					
Nominal capacity	Cooling	kW	96.0	101.0	106.5	113.0	
Electrical characteristics	Power consumption	Cooling	kW	27.70	29.46	31.52	33.58
Net weight		kg	326+358	358x2			
Refrigerant charge	R410A	kg	11.5x2				
Refrigerant piping size	Liquid line	mm(in)	ø19.05(3/4")		ø22.22(7/8")		
	Gas line	mm(in)	ø31.8(1.1/4") [ø34.92(1.3/8")]		ø38.1(1.1/2")		
Capacity connection		%	50-160	50-130			
Number of connectable indoor units			69	59	62	66	

Item	Model	FDCH1180CKXE6G	FDCH1235CKXE6G	FDCH1300CKXE6G	FDCH1360CKXE6G		
Combination (FDCH)		560CKXE6G-K	615CKXE6G	615CKXE6G	680CKXE6G		
		615CKXE6G	615CKXE6G	680CKXE6G	680CKXE6G		
Nominal horse power		42HP	44HP	46HP	48HP		
Power source		3 Phase 380V, 60Hz					
Starting current	A	16					
Max current	A	94					
Nominal capacity	Cooling	kW	118.0	123.5	130.0	136.0	
Electrical characteristics	Power consumption	Cooling	kW	37.16	40.74	45.35	49.96
Net weight		kg	377x2				
Refrigerant charge	R410A	kg	11.5x2				
Refrigerant piping size	Liquid line	mm(in)	ø22.22(7/8")				
	Gas line	mm(in)	ø38.1(1.1/2")				
Capacity connection		%	50-130				
Number of connectable indoor units			69	72	76	80	

- The data are measured under the following conditions (ISO-T1). Cooling: Indoor temp. of 27°CDB, 19°CWB, and outdoor temp. of 35°CDB.
- Sound pressure level indicates the value in an anechoic chamber. During operation these values are somewhat higher due to ambient conditions.
- 'tonne(s) of CO<sub>2</sub> equivalent' means a quantity of greenhouse gases- expressed as the product of the weight of the greenhouse gases in metric tonnes and of their global warming potential.
- [ ] : Pipe sizes applicable to European installations are shown in parentheses.

# Dimensions

All measurements in mm.

FDCH335CKXE6G-K, 400CKXE6G, 450CKXE6G

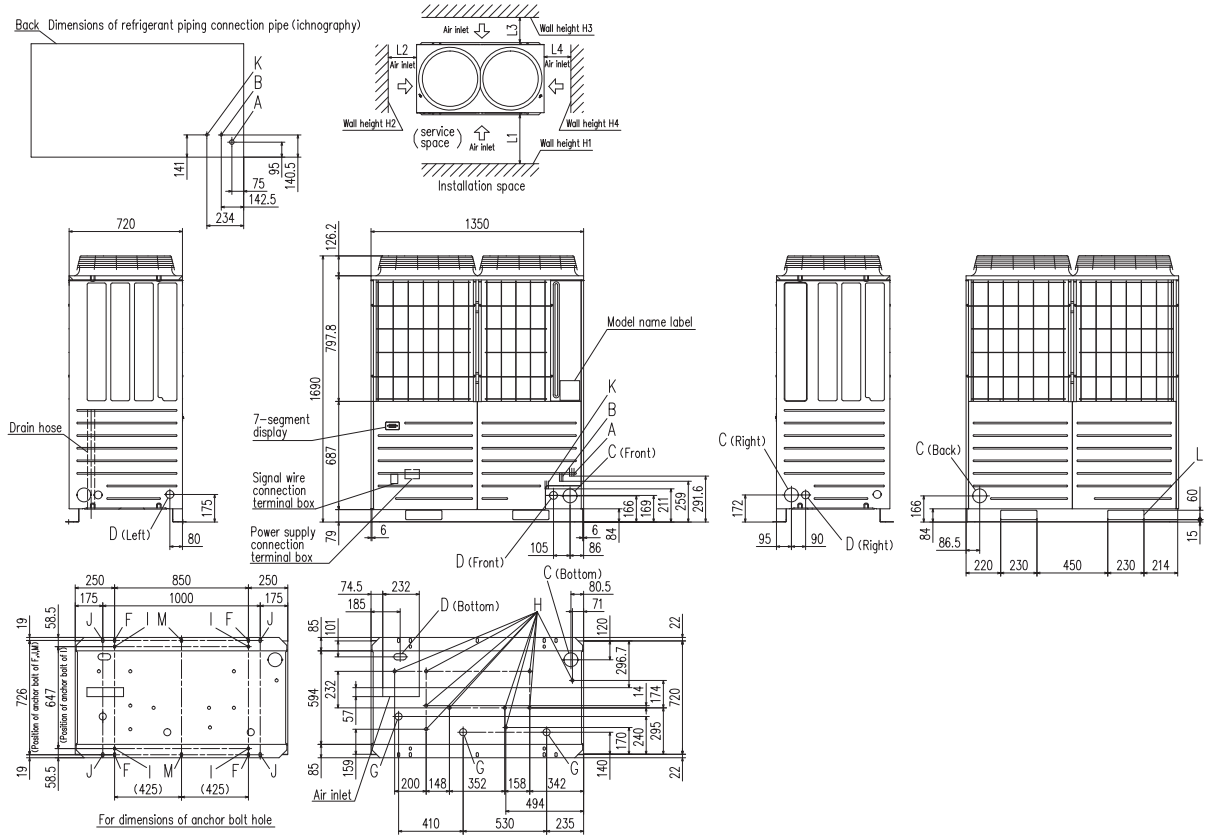

Mark	Content	335-K	400	450
A	Refrigerant gas piping connection pipe	ø25.4(Brazing)		ø28.58(Brazing)
B	Refrigerant liquid piping connection pipe	ø12.7(Flare)		
C	Refrigerant piping exit hole	ø88(or ø100)		
D	Power supply entry hole	ø50 (Right · Left · Front), Long hole 40 x 80 (Bottom)		
F	Anchor bolt hole	M10, 4 pcs		
G	Drain waste water hose hole	ø45, 3 pcs		
H	Drain hole	ø20, 10 pcs		
K	Refrigerant oil equalization piping connection pipe	ø9.52(Flare)		
L	Carrying in or hole for hanging	230 x 60		

Installation example		
Dimensions	1	2
L <sub>1</sub>	500	Open
L <sub>2</sub>	10	10
L <sub>3</sub>	100	100
L <sub>4</sub>	10	Open
H <sub>1</sub>	1500	Open
H <sub>2</sub>	No limit	No limit
H <sub>3</sub>	1000	No limit
H <sub>4</sub>	No limit	Open

**Notes:**

- (1) The unit must be fixed with anchor bolts.
- (2) Leave a 2m or larger space above the unit.
- (3) The unit name plate is attached on the lower right corner of the front panel.
- (4) The ports for refrigerant pipe and power cable penetrations are covered with half-blanks. Please cut off a half-blank with nippers in using these ports.
- (5) Use a ø88 port for refrigerant pipe connection.
- (6) Anchor holes marked "L J" (four holes for M10) are for a renewal installation.
- (7) The oil-equalising pipe K should be used when outdoor units are used in combination. (For 14,16Hp only)

**When more than one unit is installed**

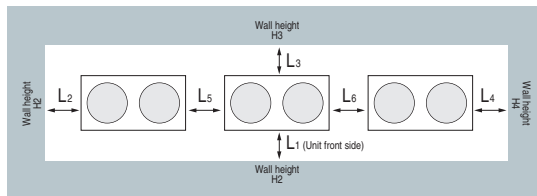

Installation example		
Dimensions	1	2
L <sub>1</sub>	500	Open
L <sub>2</sub>	10	200
L <sub>3</sub>	100	300
L <sub>4</sub>	10	Open
L <sub>5</sub>	0	400
L <sub>6</sub>	0	400
H <sub>1</sub>	1500	No limit
H <sub>2</sub>	No limit	No limit
H <sub>3</sub>	1000	No limit
H <sub>4</sub>	No limit	No limit

FDCH504CKXE6G, 560CKXE6G, 560CKXE6G-K, 615CKXE6G, 680CKXE6G

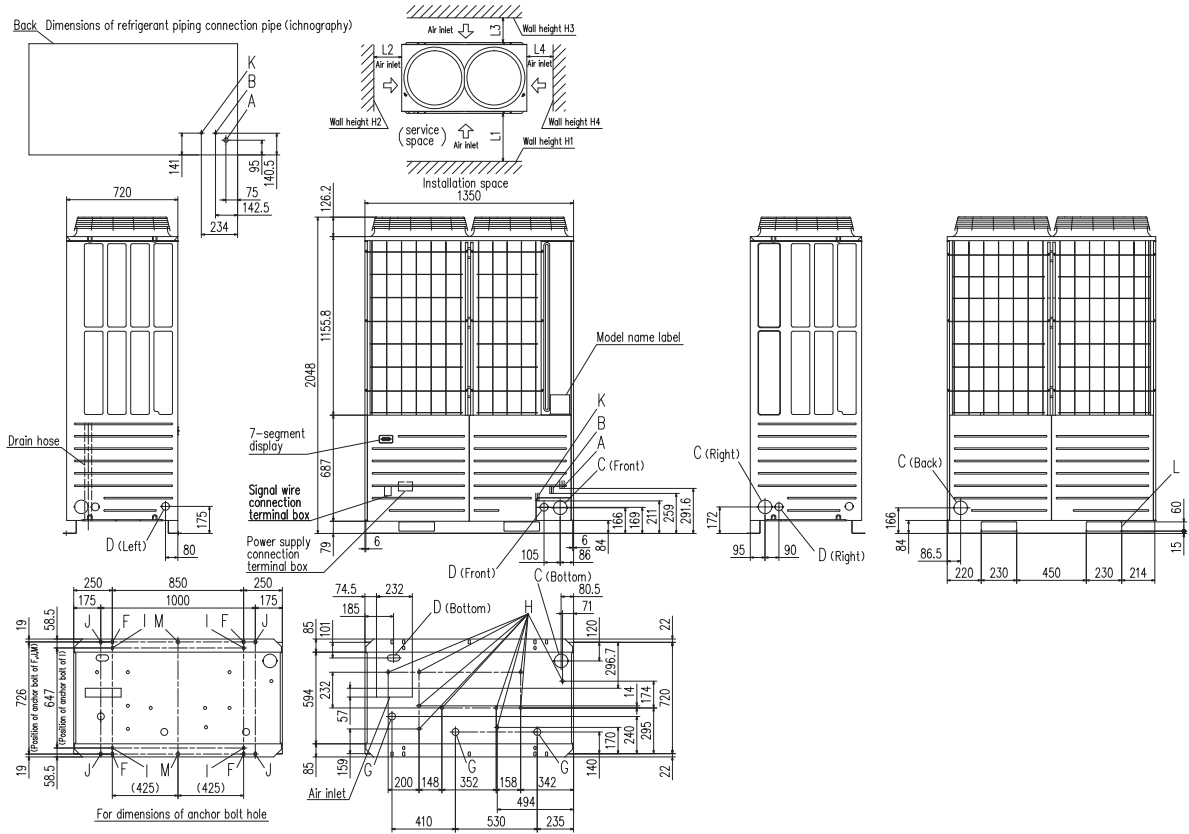

Mark	Content	
A	Refrigerant gas piping connection pipe	ø28.58(Brazing)
B	Refrigerant liquid piping connection pipe	ø12.7(Flare)
C	Refrigerant piping exit hole	ø88(or ø100)
D	Power supply entry hole	ø50 (Right · Left · Front), Long hole 40 x 80 (Bottom)
F	Anchor bolt hole	M10, 4 pcs
G	Drain waste water hose hole	ø45, 3 pcs
H	Drain hole	ø20, 10 pcs
K	Refrigerant oil equalization piping connection pipe	ø9.52(Flare)
L	Carrying in or hole for hanging	230 x 60

Installation example		
Dimensions	1	2
L <sub>1</sub>	500	Open
L <sub>2</sub>	10	10
L <sub>3</sub>	100	100
L <sub>4</sub>	10	Open
H <sub>1</sub>	1500	Open
H <sub>2</sub>	No limit	No limit
H <sub>3</sub>	1000	No limit
H <sub>4</sub>	No limit	Open

Notes:

- (1) The unit must be fixed with anchor bolts.
- (2) Leave a 2m or larger space above the unit.
- (3) The unit name plate is attached on the lower right corner of the front panel.
- (4) The ports for refrigerant pipe and power cable penetrations are covered with half-blanks. Please cut off a half-blank with nippers in using these ports.
- (5) Use a ø88 port for refrigerant pipe connection.
- (6) Anchor holes marked "L J" (four holes for M10) are for a renewal installation.
- (7) The oil-equalising pipe K should be used when outdoor units are used in combination.

# Micro KXZ Heat pump systems

## 4-6HP (11.2kW – 15.5kW)



Model No.	Nominal Cooling Capacity
FDC112KXZEN1-W	11.2kW (220V)
FDC140KXZEN1-W	14.0kW (220V)
FDC155KXZEN1-W	15.5kW (220V)
FDC112KXZES1-W	11.2kW (380V)
FDC140KXZES1-W	14.0kW (380V)
FDC155KXZES1-W	15.5kW (380V)



- Low Global Warming Potential (GWP) and High energy efficiency by new refrigerant R32.
- Connect up to 10 indoor units/up to 150% capacity.
- High efficiency with EER up to 4.39.
- These units employ DC inverter compressors ONLY.
- Industry leading total piping length up to 100m and a maximum pipe run of 70m.

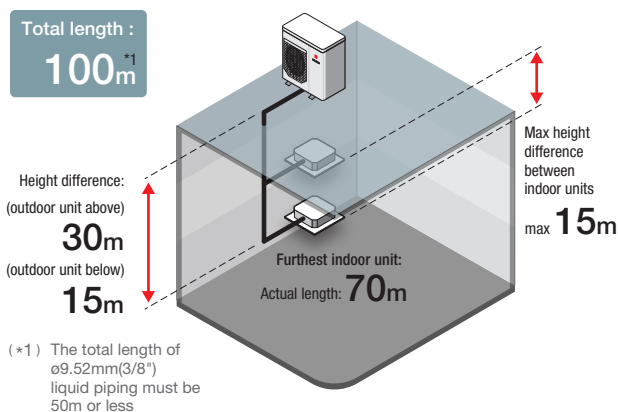

Range of operation

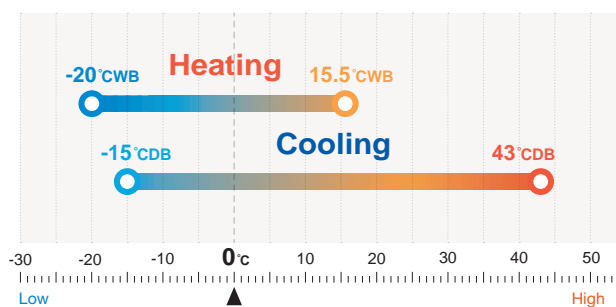

## Specifications

Item	Model	FDC112KXZEN1-W	FDC140KXZEN1-W	FDC155KXZEN1-W	FDC112KXZES1-W	FDC140KXZES1-W	FDC155KXZES1-W	
Nominal horse power		4HP	5HP	6HP	4HP	5HP	6HP	
Power source		1 Phase 220-240V, 50Hz			3 Phase 380-415V, 50Hz			
Starting current	A	5						
Max current	A	23			13.5			
Nominal capacity	Cooling	kW						
	Heating	11.2	14.0	15.5	11.2	14.0	15.5	
Electrical characteristics	Power consumption	Cooling	kW					
		Heating	2.55	4.00	5.20	2.55	4.00	5.20
Exterior dimensions	HxWxD	mm						
Net weight	kg	85			87			
Sound pressure level	Cooling/Heating	dB(A)						
Refrigerant	Type / GWP	R32 / 675						
	Charge	kg/TCO <sub>2</sub> Eq						
Refrigerant piping size	Liquid line	mm(in)						
	Gas line	mm(in)						
Capacity connection	%	80-150						
Number of connectable indoor units		8	10	10	8	10	10	

1. The data are measured under the following conditions (ISO-T1, H1). Cooling: indoor temp. of 27°CDB, 19°CWB, and outdoor temp. of 35°CDB. Heating: indoor temp. was 20°CDB, and outdoor temp. of 7°CDB, 6°CWB.  
 2. Sound pressure level indicates the value in an anechoic chamber. During operation these values were somewhat higher due to ambient conditions.  
 3. 'tonne(s) of CO<sub>2</sub> equivalent' means a quantity of greenhouse gases-expressed as the product of the weight of greenhouse gases in metric tonnes and of their global warming potential.

# Refrigerant piping

Outdoor unit (HP)		4	5	6
Gas pipe	Furthest indoor unit =<70m	ø15.88		
Liquid pipe		ø9.52		

Branch pipes



DIS-22-1G  
DIS-180-1G

Header pipe



HEAD4-22-1G  
HEAD6-180-1G

# Dimensions

All measurements in mm.

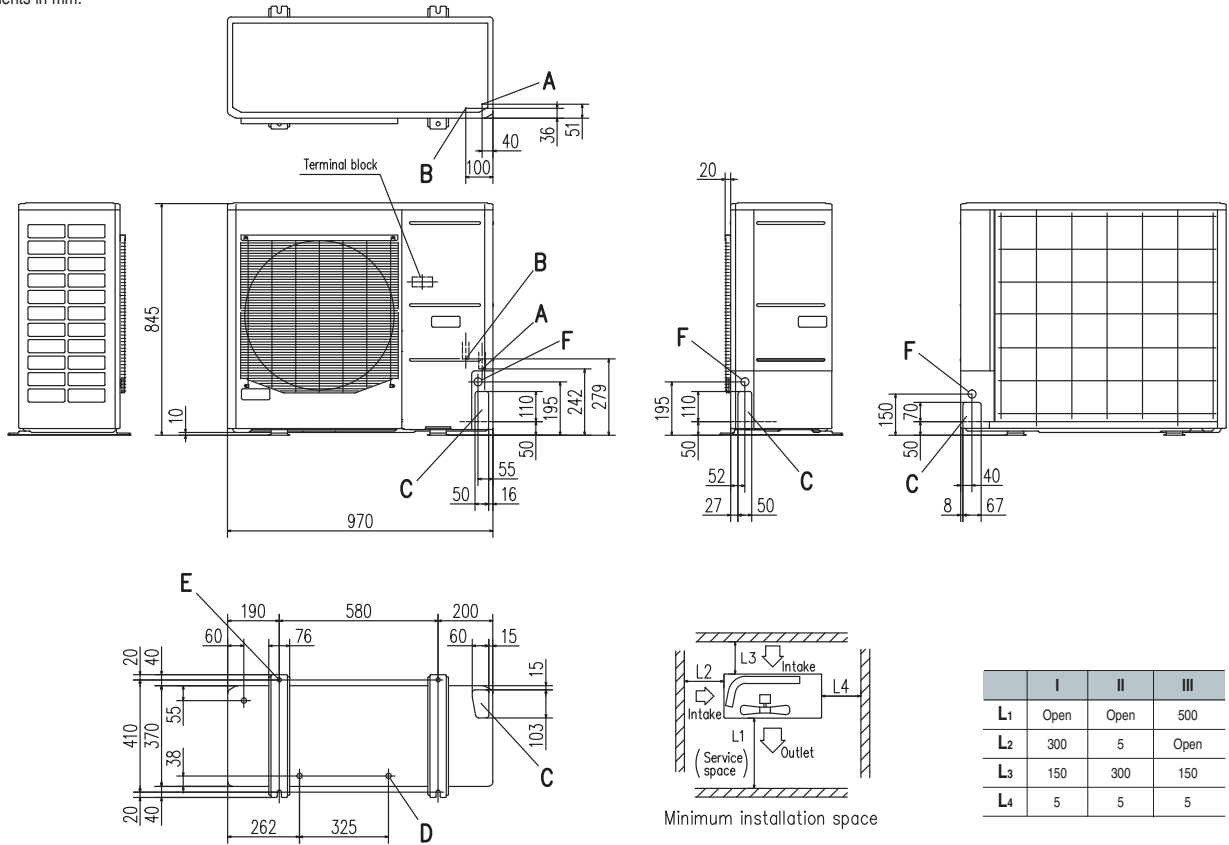

	I	II	III
L1	Open	Open	500
L2	300	5	Open
L3	150	300	150
L4	5	5	5

Mark	Content	
A	Service valve connection (gas side)	ø15.88 (5/8") (Flare)
B	Service valve connection (liquid side)	ø9.52 (3/8") (Flare)
C	Pipe/cable draw-out hole	
D	Drain discharge hole	ø20 x 3 places
E	Anchor bolt hole	M10 x 4 places
F	Cable draw-out hole	ø30 x 3 places

Notes:

- (1) It must not be surrounded by walls on the four sides.
- (2) The unit must be fixed with anchor bolts. An anchor bolt must not protrude more than 15mm.
- (3) Where the unit is subject to strong winds, lay it in such a direction that the blower outlet faces perpendicularly to the dominant wind direction.
- (4) Leave 1m or more space above the unit.
- (5) A wall in front of the blower outlet must not exceed the units height.
- (6) The model name label is attached on the lower right corner of the front panel.

## 4-6HP (11.2kW – 15.5kW)



Model No.	Nominal Cooling Capacity
FDC112KXZEN1	11.2kW (220V)
FDC140KXZEN1	14.0kW (220V)
FDC155KXZEN1	15.5kW (220V)
FDC112KXZES1	11.2kW (380V)
FDC140KXZES1	14.0kW (380V)
FDC155KXZES1	15.5kW (380V)



- Connect up to 10\* indoor units/up to 150% capacity.
- High efficiency with EER up to 4.44.
- These units employ DC inverter compressors ONLY.
- Industry leading total piping length up to 100m and a maximum pipe run of 70m.

\*When connecting 9 units or more, set the total capacity as follows : 5HP : 110% or less, 6HP : 100% or less.

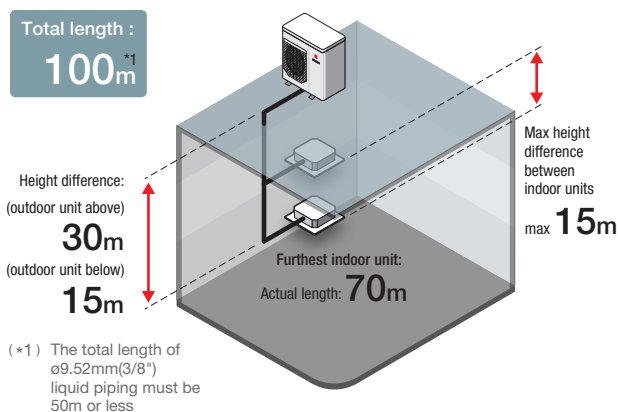

Range of operation

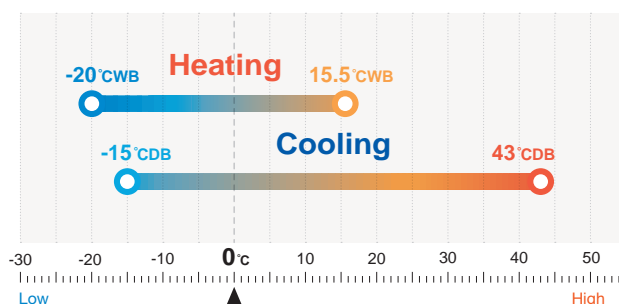

## Specifications

Item		Model	FDC112KXZEN1	FDC140KXZEN1	FDC155KXZEN1	FDC112KXZES1	FDC140KXZES1	FDC155KXZES1
Nominal horse power			4HP	5HP	6HP	4HP	5HP	6HP
Power source			1 Phase 220-240V, 50Hz			3 Phase 380-415V, 50Hz		
Starting current		A	5					
Max current		A	28			13.5		
Nominal capacity	Cooling	kW	11.2	14.0	15.5	11.2	14.0	15.5
	Heating	kW	11.2	14.0	15.5	11.2	14.0	15.5
Electrical characteristics	Power consumption	Cooling	2.52	3.96	5.20	2.52	3.96	5.20
		Heating	2.57	3.66	4.28	2.57	3.66	4.28
Exterior dimensions		HxWxD	845x970x370					
Net weight		kg	85			87		
Sound pressure level		Cooling/Heating	52/55	53/57	54/57	52/55	53/57	54/57
Refrigerant	Type / GWP		R410A / 2088					
	Charge	kg/TCO <sub>2</sub> Eq	5.0 / 10.44					
Refrigerant piping size	Liquid line	mm(in)	ø9.52(3/8")					
	Gas line	mm(in)	ø15.88(5/8")					
Capacity connection		%	80-150					
Number of connectable indoor units			8	10*	10*	8	10*	10*

1. The data are measured under the following conditions (ISO-T1, H1). Cooling: indoor temp. of 27°CDB, 19°CWB, and outdoor temp. of 35°CDB. Heating: indoor temp. was 20°CDB, and outdoor temp. of 7°CDB, 6°CWB.  
 2. Sound pressure level indicates the value in an anechoic chamber. During operation these values were somewhat higher due to ambient conditions.  
 3. 'tonne(s) of CO<sub>2</sub> equivalent' means a quantity of greenhouse gases-expressed as the product of the weight of greenhouse gases in metric tonnes and of their global warming potential.

# Refrigerant piping

Outdoor unit (HP)		4	5	6
Gas pipe	Furthest indoor unit =<70m	ø15.88		
Liquid pipe		ø9.52		

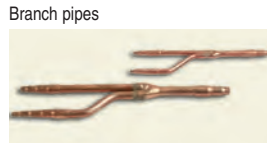

DIS-22-1G  
DIS-180-1G



HEAD4-22-1G  
HEAD6-180-1G

## Dimensions

All measurements in mm.

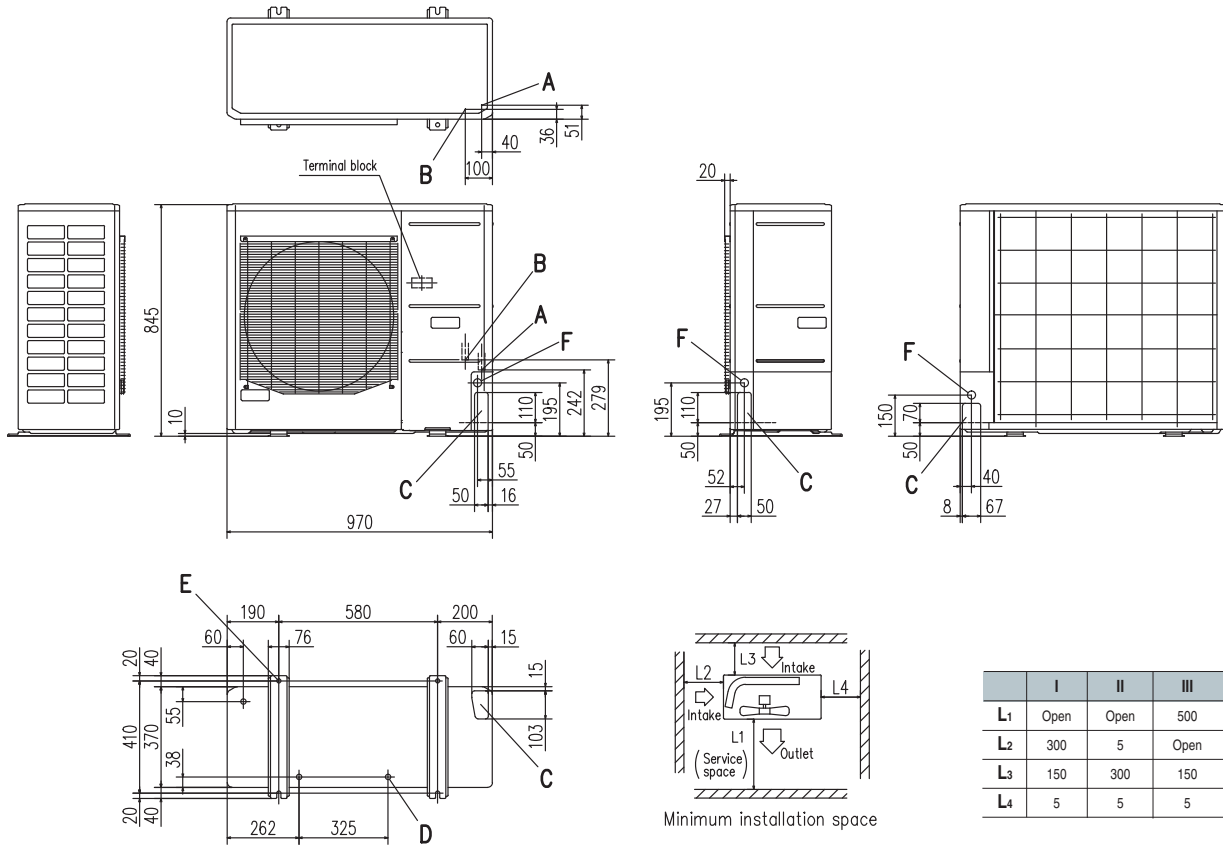

Mark	Content	
A	Service valve connection (gas side)	ø15.88 (5/8") (Flare)
B	Service valve connection (liquid side)	ø9.52 (3/8") (Flare)
C	Pipe/cable draw-out hole	
D	Drain discharge hole	ø20 x 3 places
E	Anchor bolt hole	M10 x 4 places
F	Cable draw-out hole	ø30 x 3 places

### Notes:

- (1) It must not be surrounded by walls on the four sides.
- (2) The unit must be fixed with anchor bolts. An anchor bolt must not protrude more than 15mm.
- (3) Where the unit is subject to strong winds, lay it in such a direction that the blower outlet faces perpendicularly to the dominant wind direction.
- (4) Leave 1m or more space above the unit.
- (5) A wall in front of the blower outlet must not exceed the units height.
- (6) The model name label is attached on the lower right corner of the front panel.

# Micro KX Heat pump systems

## 4-6HP (11.2kW – 15.5kW)



Model No.	Nominal Cooling Capacity
FDC112KXEN6	11.2kW (220V)
FDC140KXEN6	14.0kW (220V)
FDC155KXEN6	15.5kW (220V)
FDC112KXES6	11.2kW (380V)
FDC140KXES6	14.0kW (380V)
FDC155KXES6	15.5kW (380V)



Note: FDUT15KXE6F-E, FDTC15KXZE1 and FDK15KXZE1 can not be connected to the above systems.

- Connect up to 8 indoor units/up to 150% capacity.
- High efficiency with (EER) up to 4.00.
- These units employ DC inverter compressors ONLY.
- Industry leading total piping length up to 100m and a maximum pipe run of 70m.

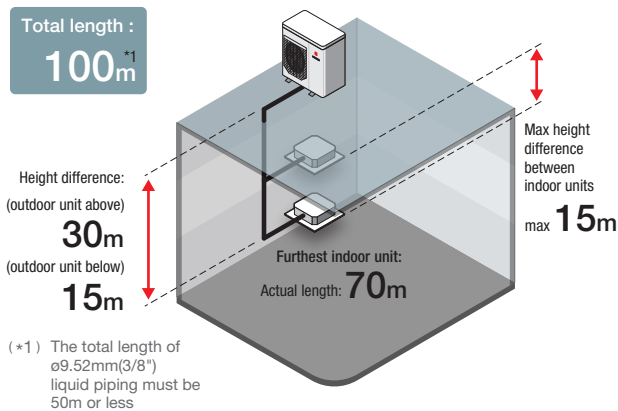

### Range of operation

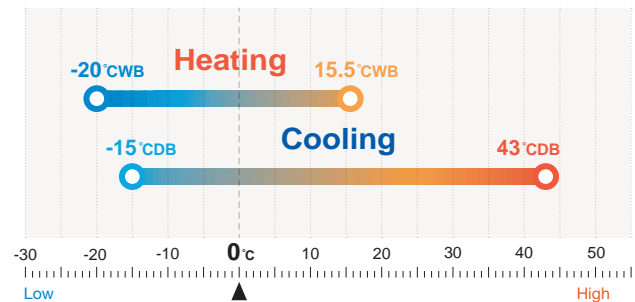

## Specifications

Item	Model	FDC112KXEN6	FDC140KXEN6	FDC155KXEN6	FDC112KXES6	FDC140KXES6	FDC155KXES6	
Nominal horse power		4HP	5HP	6HP	4HP	5HP	6HP	
Power source		1 Phase 220-240V, 50Hz			3 Phase 380-415V, 50Hz			
Starting current	A	5						
Max current	A	28			13.5			
Nominal capacity	Cooling	11.2	14.0	15.5	11.2	14.0	15.5	
	Heating	12.5	16.0	16.3	12.5	16.0	16.3	
Electrical characteristics	Power consumption	Cooling	2.80	4.17	4.71	2.80	4.17	4.71
		Heating	2.89	4.31	4.38	2.89	4.31	4.38
Exterior dimensions	HxWxD	mm 845x970x370						
Net weight	kg	85			87			
Sound pressure level	Cooling/Heating	52/54	53/57	53/57	52/54	53/57	53/57	
Refrigerant	Type / GWP	R410A / 2088						
	Charge	kg/TCO <sub>2</sub> Eq 5.0 / 10.44						
Refrigerant piping size	Liquid line	mm(in) ø9.52(3/8")						
	Gas line	mm(in) ø15.88(5/8")						
Capacity connection	%	80-150						
Number of connectable indoor units		6	8	8	6	8	8	

1. The data are measured under the following conditions(ISO-T1). Cooling: Indoor temp. of 27°CDB, 19°CWB, and outdoor temp. of 35°CDB. Heating: Indoor temp. of 20°CDB, and outdoor temp. of 7°CDB, 6°CWB.  
 2. Sound pressure level indicates the value in an anechoic chamber. During operation these values are somewhat higher due to ambient conditions.  
 3. 'tonne(s) of CO<sub>2</sub> equivalent' means a quantity of greenhouse gases- expressed as the product of the weight of the greenhouse gases in metric tonnes and of their global warming potential.

# Refrigerant piping

Outdoor unit (HP)		4	5	6
Gas pipe	Furthest indoor unit =<70m	ø15.88		
Liquid pipe		ø9.52		

Branch pipes



DIS-22-1G  
DIS-180-1G

Header pipe



HEAD4-22-1G  
HEAD6-180-1G

# Dimensions

All measurements in mm.

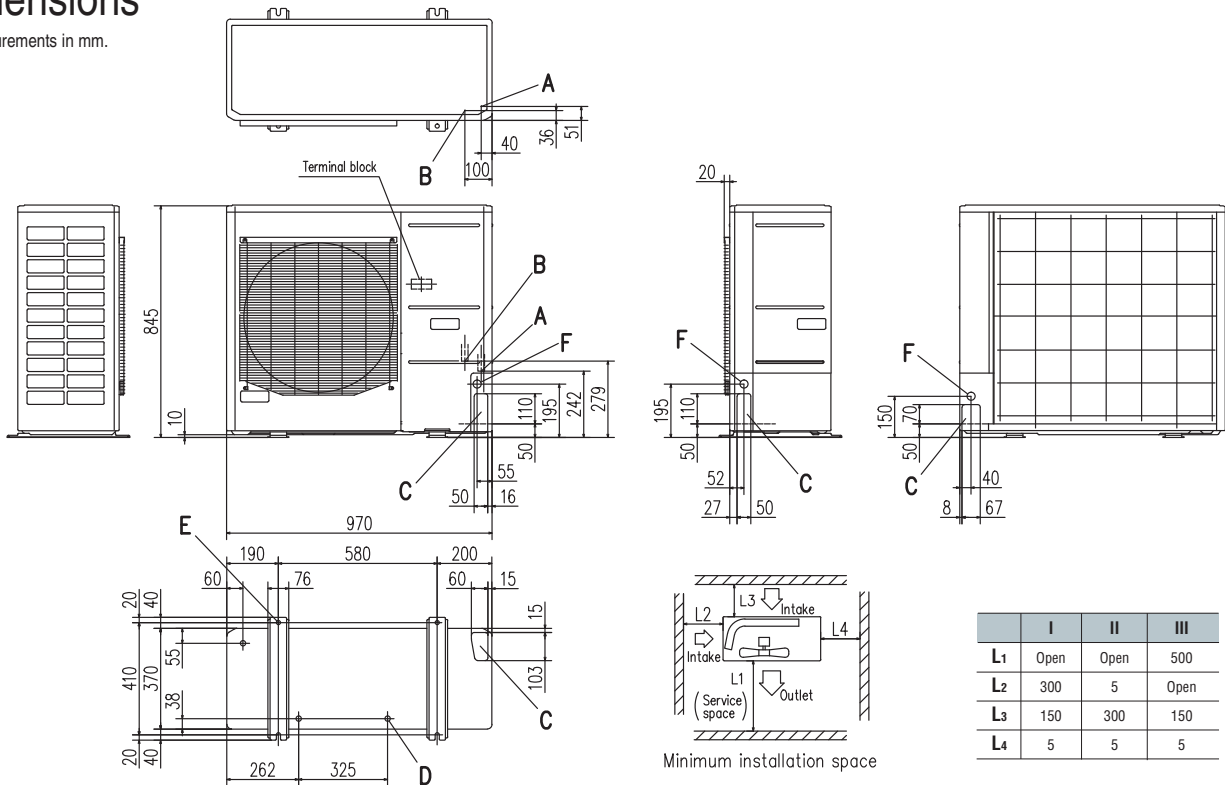

	I	II	III
L1	Open	Open	500
L2	300	5	Open
L3	150	300	150
L4	5	5	5

Mark	Content	
A	Service valve connection (gas side)	ø15.88 (5/8") (Flare)
B	Service valve connection (liquid side)	ø9.52 (3/8") (Flare)
C	Pipe/cable draw-out hole	
D	Drain discharge hole	ø20 x 3 places
E	Anchor bolt hole	M10 x 4 places
F	Cable draw-out hole	ø30 x 3 places

Notes:

- (1) It must not be surrounded by walls on the four sides.
- (2) The unit must be fixed with anchor bolts. An anchor bolt must not protrude more than 15mm.
- (3) Where the unit is subject to strong winds, lay it in such a direction that the blower outlet faces perpendicularly to the dominant wind direction.
- (4) Leave 1m or more space above the unit.
- (5) A wall in front of the blower outlet must not exceed the units height.
- (6) The model name label is attached on the lower right corner of the front panel.

# Micro KX Heat pump systems

## 8-12HP (22.4kW – 33.5kW)



Model No.	Nominal Cooling Capacity
FDC224KXE6G	22.4kW
FDC280KXE6G	28.0kW
FDC335KXE6G	33.5kW



- Connect up to 24 indoor units/up to 150% capacity.
- High efficiency with EER up to 4.00.
- These units employ DC inverter compressors ONLY.
- Industry leading total piping length up to 510m and a maximum pipe run of 160m.

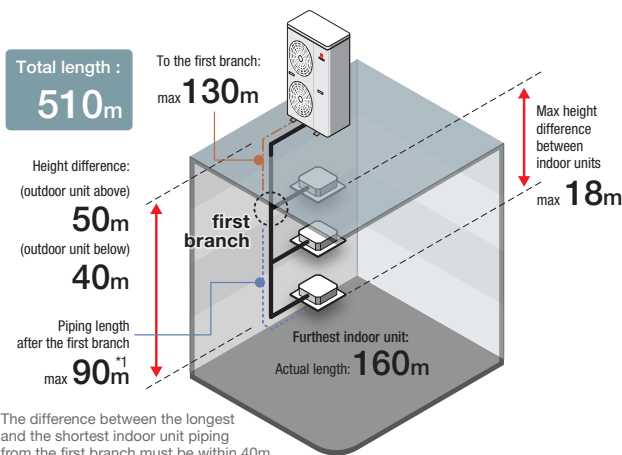

Range of operation

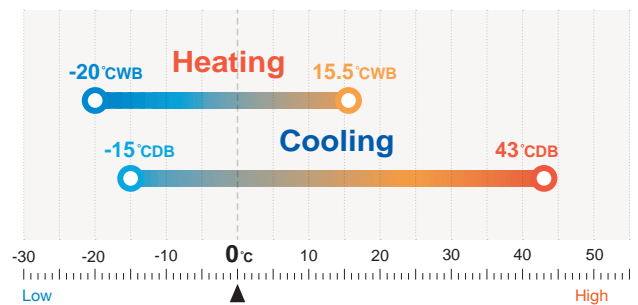

## Specifications

Item		Model	FDC224KXE6G	FDC280KXE6G	FDC335KXE6G
Nominal horse power			8HP	10HP	12HP
Power source			3 Phase 380-415V, 50Hz		
Starting current		A	5		
Max current		A	20		23
Nominal capacity	Cooling	kW	22.4	28.0	33.5
	Heating	kW	25.0	31.5	37.5
Electrical characteristics	Power consumption	Cooling	5.60	8.09	9.82
		Heating	6.03	8.21	10.12
Exterior dimensions	HxWxD	mm	1675x1080x480		
Net weight		kg	215		218
Sound pressure level	Cooling/Heating	dB(A)	58/58	59/60	61/61
Refrigerant	Type / GWP		R410A / 2088		
	Charge	kg/TCO <sub>2</sub> Eq	11.5 / 24.012		
Refrigerant piping size	Liquid line	mm(in)	ø9.52(3/8")		ø12.7(1/2")
	Gas line	mm(in)	ø19.05(3/4")	ø22.22(7/8")	ø25.4(1") [ø22.22(7/8")]
Capacity connection		%	50-150		
Number of connectable indoor units			22	24	24

1. The data are measured under the following conditions(ISO-T1). Cooling: Indoor temp. of 27°CDB, 19°CWB, and outdoor temp. of 35°CDB. Heating: Indoor temp. of 20°CDB, and outdoor temp. of 7°CDB, 6°CWB.  
 2. Sound pressure level indicates the value in an anechoic chamber. During operation these values are somewhat higher due to ambient conditions.  
 3. 'tonne(s) of CO<sub>2</sub> equivalent' means a quantity of greenhouse gases- expressed as the product of the weight of the greenhouse gases in metric tonnes and of their global warming potential.  
 4. [ ] : Pipe sizes applicable to European installations are shown in parentheses.

# Refrigerant piping

Outdoor unit (HP)		Micro KX			KXZ Lite	
		8	10	12	8	10
Gas pipe	Furthest indoor unit =<90m	ø19.05	ø22.22	ø25.4(ø22.22)	ø19.05	ø22.22
Liquid pipe		ø9.52		ø12.7	ø9.52	
Gas pipe	90m	ø22.22	ø25.4(ø22.22)		ø22.22	ø25.4 / ø28.58
Liquid pipe	=<Furthest indoor unit	ø12.7			ø9.52	

Branch pipes



DIS-22-1G  
DIS-180-1G



DIS-371-1G

Header pipe



HEAD4-22-1G  
HEAD6-180-1G  
HEAD8-371-2

# Dimensions

All measurements in mm.

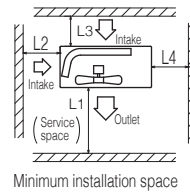
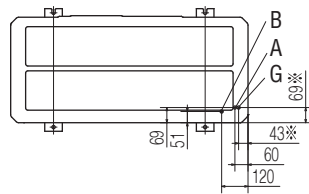

	I	II	II
L1	Open	Open	1500
L2	300	5	Open
L3	300	300	300
L4	5	5	5

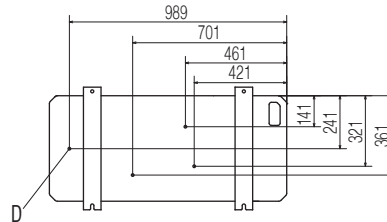
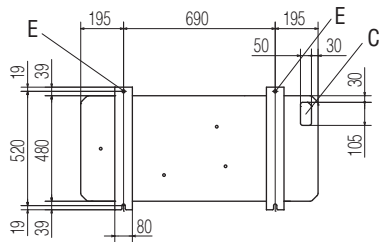
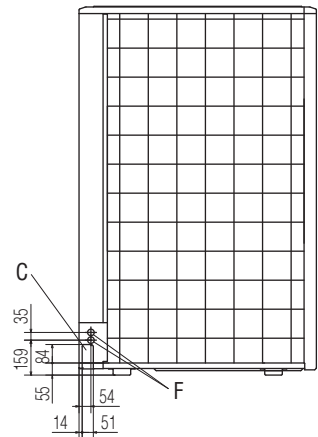
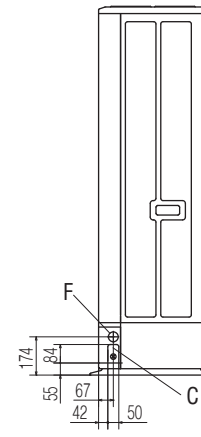
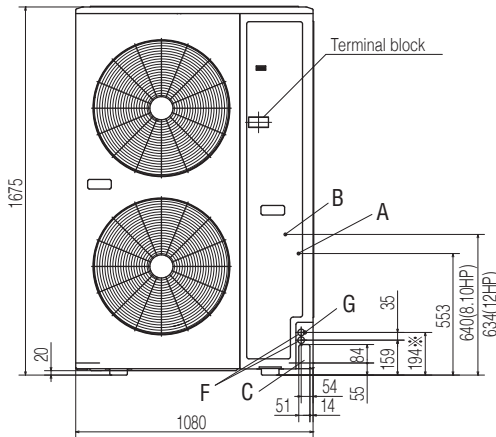
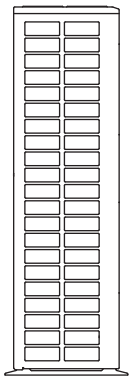

Mark	Content	224	280	335
A	Service valve connection of the attached connecting pipe (gas side)	ø19.05 (3/4") (Flare)	ø19.05 (3/4") (Flare)	ø19.05 (3/4") (Flare)
B	Service valve connection (liquid side)	ø9.52 (3/8") (Flare)	ø9.52 (3/8") (Flare)	ø12.7 (1/2") (Flare)
C	Pipe/cable draw-out hole	4places	4places	4places
D	Drain discharge hole	ø20 x 4places	ø20 x 4places	ø20 x 4places
E	Anchor bolt hole	M10 x 4places	M10 x 4places	M10 x 4places
F	Cable draw-out hole	ø30 x 2places (front) ø45 (side) ø30 x 2places (back)	ø30 x 2places (front) ø45 (side) ø30 x 2places (back)	ø30 x 2places (front) ø45 (side) ø30 x 2places (back)
G	Connecting position of the local pipe. (gas side)	ø19.05 (3/4")(Brazing)	ø22.22 (7/8")(Brazing)	ø25.4 (1")(Brazing)

### Notes:

- (1) It must not be surrounded by walls on the four sides.
- (2) The unit must be fixed with anchor bolts. An anchor bolt must not protrude more than 15mm.
- (3) Where the unit is subject to strong winds, the blower outlet should face perpendicularly to the dominant wind direction.
- (4) Leave a 1m or more space above the unit.
- (5) A wall in front of the blower outlet must not exceed the unit's height.
- (6) The model name label is attached on the lower right corner of the front.
- (7) Connect the Service valve with local pipe by using the pipe of the attachment.(Gas side only)
- (8) Mark ※ shows the connecting position of the local pipe.(Gas side only)

# KXZ Lite Heat pump systems

## 8,10HP (22.4kW, 28.0kW)



Model No.	Nominal Cooling Capacity
FDC224KXZPE1	22.4kW
FDC280KXZPE1	28.0kW

- Connect up to 8 indoor units/up to 120% capacity.
- High efficiency with EER up to 4.00.
- These units employ DC inverter multiport compressors with concentrated winding motor.
- KXZ Lite extends a cooling range operation up to 50°C.
- External static pressure is available up to 35 Pa.
- Tropical usage mode.

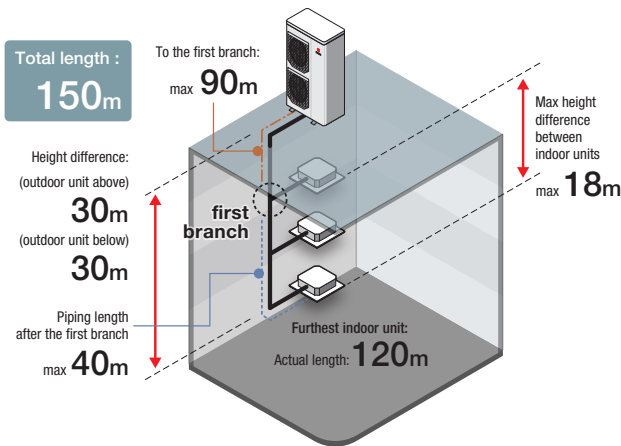

Range of operation

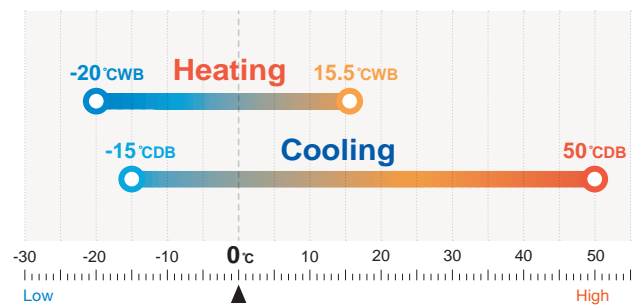

## Specifications

Item		Model	FDC224KXZPE1	FDC280KXZPE1	
Nominal horse power			8HP	10HP	
Power source			3 Phase 380-415V, 50Hz		
Starting current		A	5		
Max current		A	21	22	
Nominal capacity	Cooling	kW	22.4	28.0	
	Heating	kW	22.4	28.0	
Electrical characteristics	Power consumption	Cooling	kW	5.6	7.87
		Heating	kW	4.8	6.47
Exterior dimensions	HxWxD	mm	1505x970x370		
Net weight		kg	165		
Sound pressure level	Cooling/Heating	dB(A)	59/60	60/63	
Refrigerant	Type / GWP		R410A / 2088		
	Charge	kg/TCO2Eq	8.9 / 18.583		
Refrigerant piping size	Liquid line	mm(in)	ø9.52(3/8")		
	Gas line	mm(in)	ø19.05(3/4")	ø22.22(7/8")	
Capacity connection		%	50-120		
Number of connectable indoor units			8	8	

1. The data are measured under the following conditions(ISO-T1, H1). Cooling: Indoor temp. of 27°CDB, 19°CWB, and outdoor temp. of 35°CDB. Heating: Indoor temp. of 20°CDB, and outdoor temp. of 7°CDB, 6°CWB.  
 2. Sound pressure level indicates the value in an anechoic chamber. During operation these values are somewhat higher due to ambient conditions.  
 3. 'tonne(s) of CO<sub>2</sub> equivalent' means a quantity of greenhouse gases- expressed as the product of the weight of the greenhouse gases in metric tonnes and of their global warming potential.

# Serviceability

## Improved freedom of piping layout

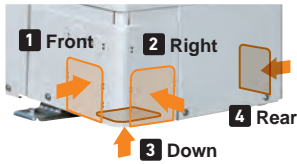

Hole size became 120% bigger.

## A transparent rain cover

Attached as a standard for easy maintenance.

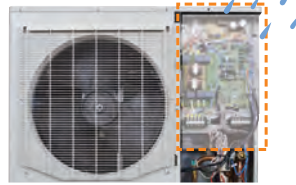

## Wire insertion holes for fall prevention



## Four handles



Located at the same level for easy transport and transfer.

## Fixing screws to service panel

Decreased number of screws from 5 to 2, installation & service speed is improved.

# Refrigerant piping

Please refer to page 69.

# Dimensions

All measurements in mm.

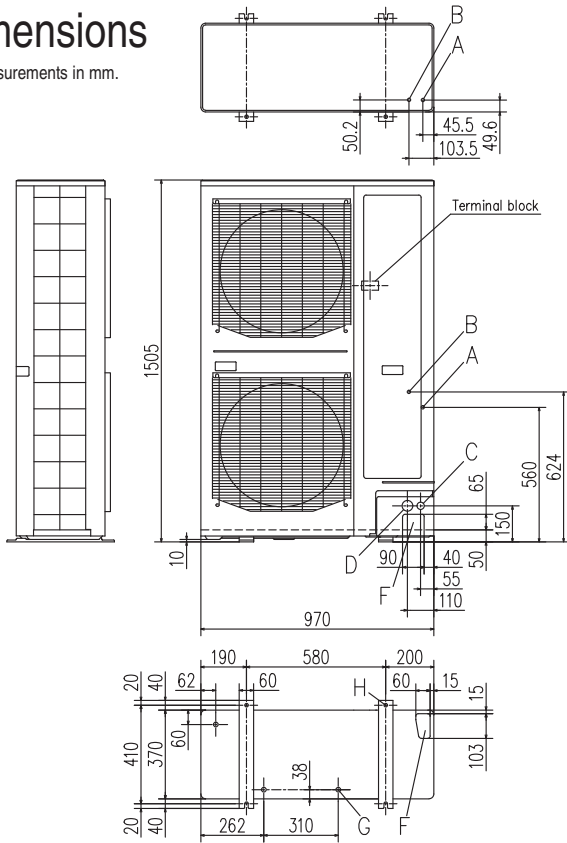

	I	II	III
L1	Open	Open	500
L2	300	5	Open
L3	150	300	150
L4	250 (5)*1	250 (5)*1	250 (5)*1

Notes:

\*1 At the time of the installation at ( ) dimension, Secure space of 250mm in lateral (L4) by unit movement at the time of the exchange work of the compressor.

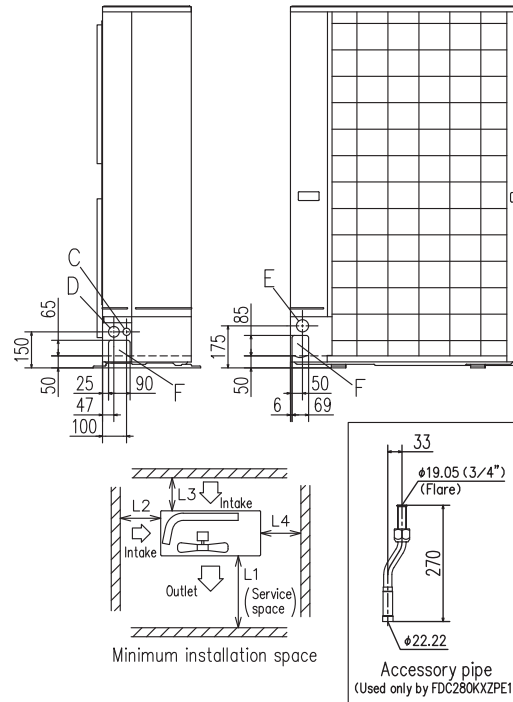

Mark	Content	
A	Service valve connection of the attached connecting pipe (gas side)	ø19.05 (3/4") (Flare)
B	Service valve connection (liquid side)	ø9.52 (3/8") (Flare)
C	Cable draw-out hole (front · side)	ø30 x 2places
D	Cable draw-out hole (front · side)	ø45 x 2places
E	Cable draw-out hole (back)	ø50
F	Pipe/cable draw-out hole	4places
G	Drain discharge hole	ø20 x 3places
H	Anchor bolt hole	M10 x 4places

Notes:

- (1) It must not be surrounded by walls on the four sides.
- (2) The unit must be fixed with anchor bolts.  
An anchor bolt must not protrude more than 15mm.
- (3) Where the unit is subject to strong winds, lay it in such a direction that the blower outlet faces perpendicularly to the dominant wind direction.
- (4) Leave 1m or more space above the unit.
- (5) A wall in front of the blower outlet must not exceed the units height.
- (6) The model name label is attached on the lower right corner of the front panel.
- (7) Connect the Service valve with local pipe by using the pipe of the attachment.  
(Gas side only) (Accessory pipe is used only by FDC280KXZPE1)
- (8) Regarding attaching the pipe of accessories, refer to an attached installation manual.

# Refrigerant piping

## Installation of Interconnecting Pipework

KXZ equipment is manufactured to meet the highest standards of quality and reliability. It is imperative that the method of installation and the materials used are also to the high standards, to ensure trouble free operation and long term reliability.

The interconnecting pipework must be installed by a competent and trained engineer. Refrigeration quality copper tube must be used, soft copper coils or half-hard straight lengths. The refrigeration quality tube must be soft drawn seamless high grade copper pipe. The copper tube must be selected taking into account the higher operating pressures of R32 · R410A refrigerant, and that high pressures will occur throughout the system because of the reverse cycle operation. All pipework material used should comply with EN12735 European standard.

The supplied branch pipe kits, must be used to make connections to indoor units, and the supplied manifold kits must be used to make connections between outdoor units (where applicable); it is not permitted to use standard fittings such as elbows, tees etc. The branch pipes shall be installed in accordance with the manufacturer's instructions, allowing unrestricted flow of refrigerant, and in accordance with European standard EN378.

All brazed joints shall be made with dry nitrogen purge to ensure the prevention of oxidisation of the internal surface of the copper pipes.

The ingress of moisture, dirt and any other contaminants to the interior of the copper pipes, and air conditioning units, must be prevented during the installation procedure.

After the installation of pipework, prior to the connection of the outdoor units, and sealing of insulation joints, the pipework must be pressure tested for leakage, using dry nitrogen.

## Additional Refrigerant

Only R32 · R410A refrigerant shall be used, it must be charged by weight only, using electronic scales. The amount of additional refrigerant must be accurately calculated from the manufacturer's data, based on the length and diameter of each section of the liquid refrigerant pipework of the system.

The products contains fluorinated greenhouse gases covered by Kyoto protocol.

## Standard (Outdoor unit side branching pipe – Indoor unit side first branching pipe)

If the longest distance (measured between the outdoor unit and the farthest indoor unit) is 90m or longer (actual length), please change the main pipe size according to the table below.

Outdoor unit	Main pipe size (normal)		Pipe size for an actual length of 90m or longer	
	Gas pipe	Liquid pipe	Gas pipe	Liquid pipe
280	ø22.22 × t 1.0	ø9.52 × t 0.8	ø25.4 (ø22.22) × t 1.0	ø12.7 × t 0.8
335	ø25.4 (ø22.22) × t 1.0	ø12.7 × t 0.8		
400	ø25.4 (ø28.58) × t 1.0		ø28.58 × t 1.0	
450	ø28.58 × t 1.0		ø12.7 × t 0.8	ø15.88 × t 1.0
475				
500				
560				
615				
670				
735	ø31.8 × t 1.1 (ø34.92 × t 1.2)		ø15.88 × t 1.0	ø19.05 × t 1.0
800				
850				
900				
950	ø38.1 × t 1.35 (ø34.92 × t 1.2)	ø19.05 × t 1.0	ø22.22 × t 1.0	
1000				
1060				
1120				
1200				
1250				
1300				
1350				
1425				
1450				
1500				
1560				
1620				
1680				

Please use C1220T-1/2H for ø19.05 or larger pipes.

Pipe sizes applicable to European installations are shown in parentheses.

mm	inch	mm	inch
ø9.52	3/8"	ø28.58	1 1/8"
ø12.7	1/2"	ø31.8	1 1/4"
ø15.88	5/8"	ø34.92	1 3/8"
ø19.05	3/4"	ø38.1	1 1/2"
ø22.22	7/8"	ø44.5	1 3/4"
ø25.4	1"	ø50.8	2"

Branch pipes



DIS-22-1G/DIS-180-1G

Header pipe



HEAD6-180-1G



DIS-371-1G/DIS-540-3

Combination outdoor unit manifold



DOS-2A-3  
DOS-3A-3

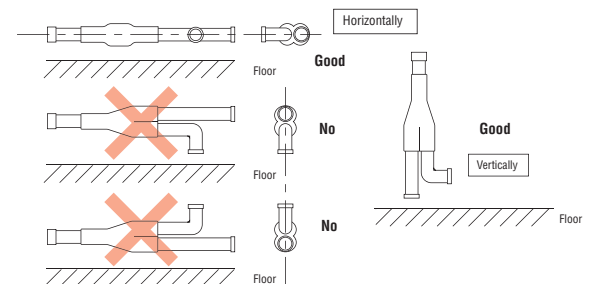

## Single outdoor unit piping examples:

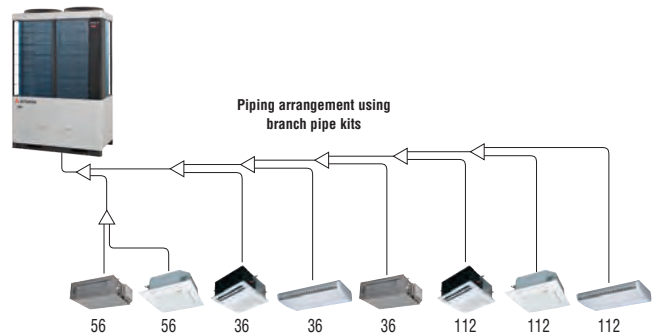
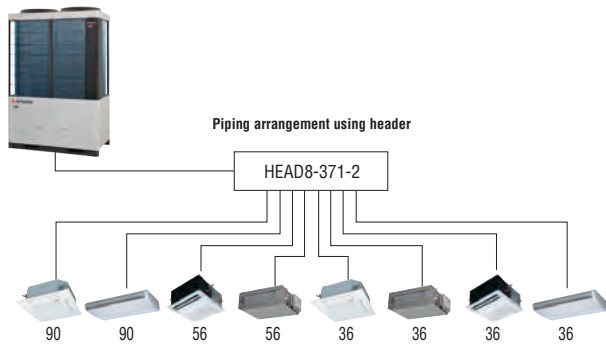

## Combination outdoor unit piping examples:

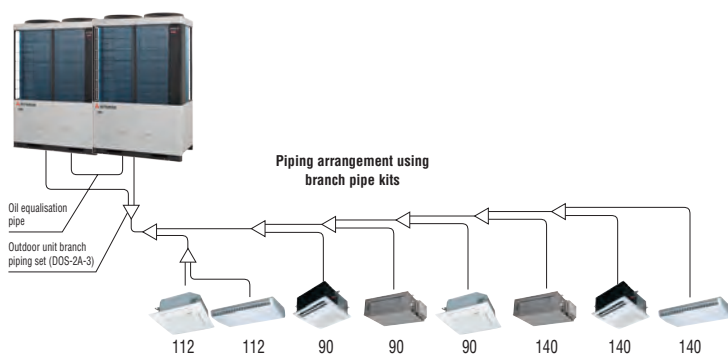

Outdoor unit's branch piping set

Outdoor unit	Branch piping set
For two units	DOS-2A-3
For three units	DOS-3A-3

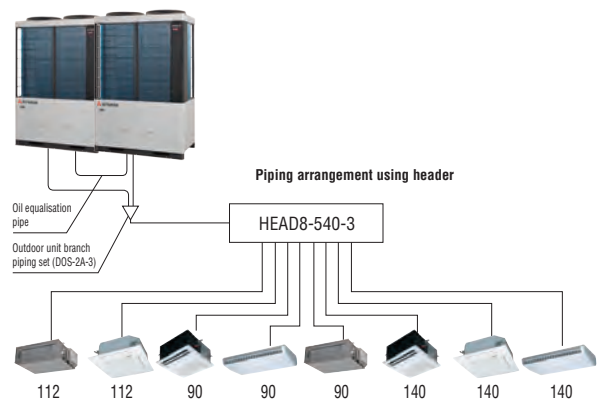

Indoor unit's first branch piping set

Total capacity of indoor units	Branch piping set	Header set	
		Model	Branches
Less than 180	DIS-22-1G	HEAD4-22-1G	Max 4 branches
180 or more but less than 371	DIS-180-1G	HEAD6-180-1G	Max 6 branches
371 or more but less than 540	DIS-371-1G	HEAD8-371-2	Max 8 branches
540 or more	DIS-540-3	HEAD8-540-3	Max 8 branches

# Electrical wiring – power supply

KXZ has greatly simplified wiring requirements utilising a 'polarity-free' two wire control loop connecting the indoor units.

## Power wiring

Cables can be laid through the front, right, left or bottom of the outdoor unit casing.

Separate power supplies should be used for the outdoor unit (3Phase) and the indoor units (1Phase).

Only control wiring is connected from outdoor to indoor unit.

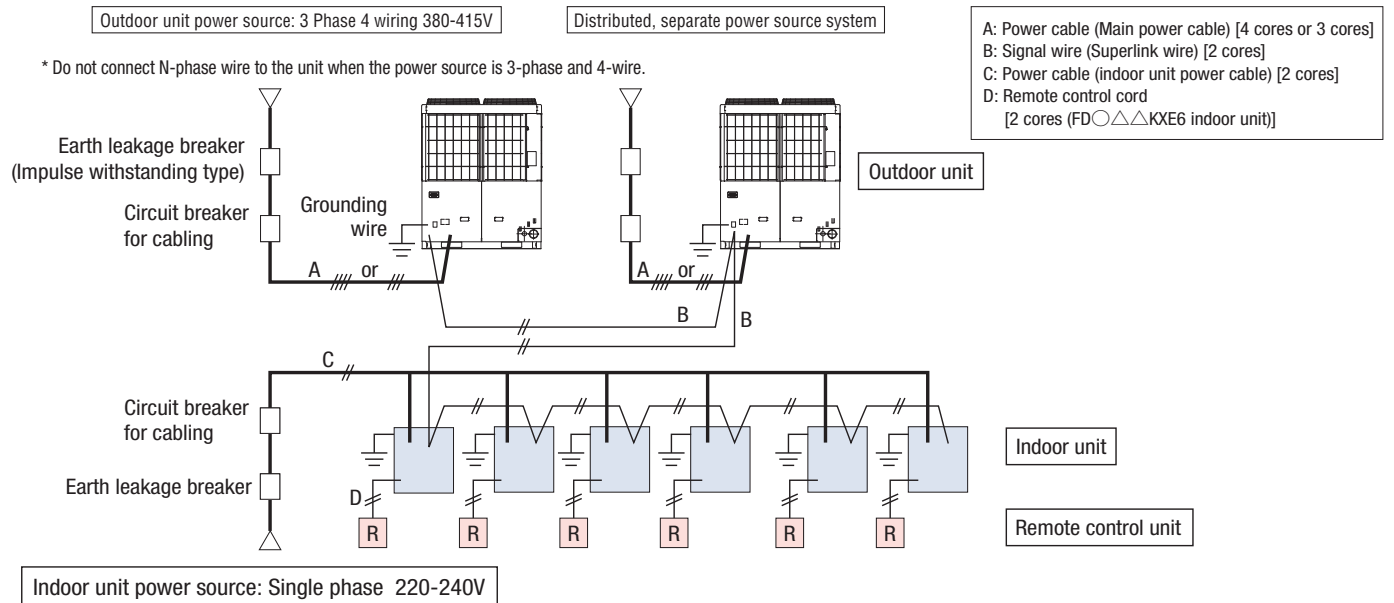

## CAUTION

If the earth leakage breaker is exclusively for ground fault protection, then you will need to install a circuit breaker for wiring work.

# Electrical wiring – control wiring

1. The control wiring is 5 Volt DC, non-polarised, two wire connection notated as 'A1' and 'B1'. This 'AB' wiring connects outdoor unit to indoor unit and indoor unit to indoor unit.

2. This wiring must be a 2-core shielded cable size 0.75mm<sup>2</sup> or 1.25mm<sup>2</sup>.

	0.75mm <sup>2</sup>	1.25mm <sup>2</sup>
UP to 1000m	YES	YES
1000–1500m	YES	NO

3. We recommend both ends of the shield of the cable are connected to ground (earth) at all the indoor units and outdoor units.

4. When multiple outdoor units are used,

- Connect the signal cable between indoor and outdoor units and the signal cable between outdoor units belonging to the same refrigerant line to A1 and B1.
- Connect the signal line between outdoor units on different refrigerant lines to A2 and B2.

5. For current specification of 2-core (AB) wiring, please consult your dealer.

(1) When one outdoor unit is used

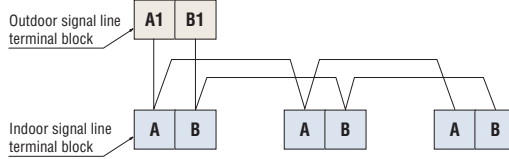

○ Indoor and outdoor signal lines do not have a polarity. Any of the connections in the following illustration can be made.

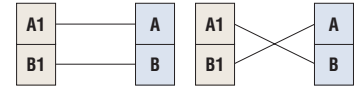

(2) When plural outdoor units are used

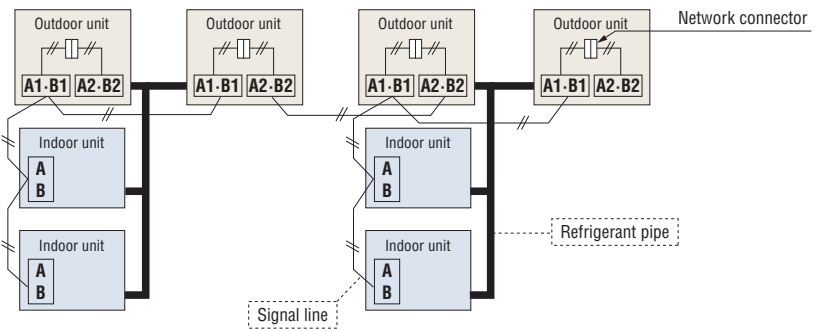

The maximum number of indoor units that can be connected in a system is 128 and it is possible to configure outdoor units and/or indoor units as an outdoor or indoor unit group connected with each other with two wires.

(3) The signal lines can also be connected using the method shown below.

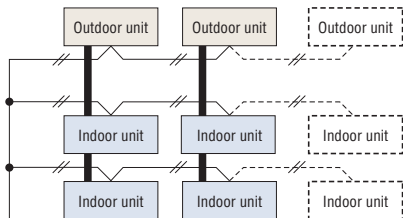

**Important** ○ Loop wiring prohibited

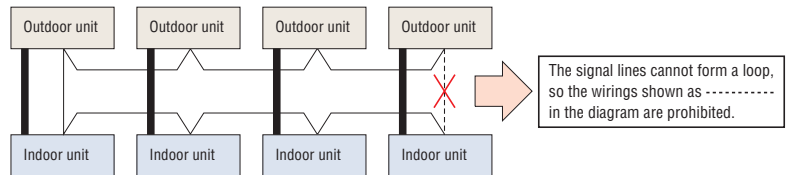

# Remote control wiring specifications

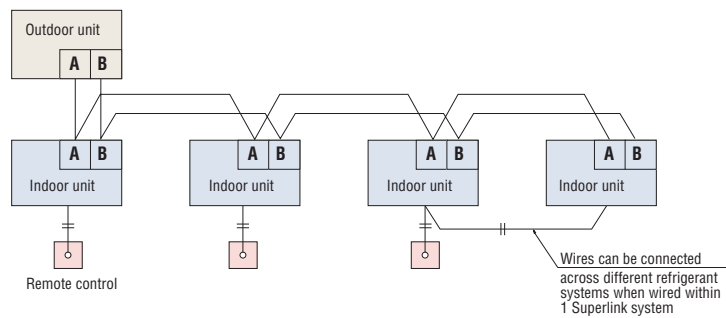

For interconnecting wiring between the remote control and indoor units (XY wiring) use 2-core cable size 0.3mm<sup>2</sup>. The maximum length of 2-core cable is 600 metres. Where the 2-core wiring exceeds 100m, use the wire size detailed on the table below.

Length (m)	Wire size
100 to 200	0.5mm <sup>2</sup> x 2 core
To 300	0.75mm <sup>2</sup> x 2 core
To 400	1.25mm <sup>2</sup> x 2 core
To 600	2.0mm <sup>2</sup> x 2 core



# Indoor units



17 types of exposed or concealed indoor units available in a wide range of capacities. The best solution of indoor units for all applications is available from our full lineup.

			1.5kW <0.5HP>	2.2kW <0.8HP>	2.8kW <1HP>	3.6kW <1.25HP>	
Ceiling Cassette	4way FDT				FDT28KXZE1-W	FDT36KXZE1-W	
					FDT28KXZE1	FDT36KXZE1	
	4way Compact FDTC		FDTC15KXZE1-W	FDTC22KXZE1-W	FDTC28KXZE1-W	FDTC36KXZE1-W	
			FDTC15KXZE1	FDTC22KXZE1	FDTC28KXZE1	FDTC36KXZE1	
	2way FDTW				FDTW28KXE6F		
1way FDTS							
1way Compact FDTQ			FDTQ22KXE6F	FDTQ28KXE6F	FDTQ36KXE6F		
Duct Connected	High Static Pressure FDU						
	Low/Middle Static Pressure FDUM			FDUM22KXE6F-W	FDUM28KXE6F-W	FDUM36KXE6F-W	
					FDUM22KXE6F	FDUM28KXE6F	FDUM36KXE6F
	Low Static Pressure(thin) FDUT		FDUT15KXE6F-W	FDUT22KXE6F-W	FDUT28KXE6F-W	FDUT36KXE6F-W	
		FDUT15KXE6F-E	FDUT22KXE6F-E	FDUT28KXE6F-E	FDUT36KXE6F-E		
Compact & Flexible FDUH			FDUH22KXE6F	FDUH28KXE6F	FDUH36KXE6F		
Wall Mounted FDK			FDK15KXZE1-W	FDK22KXZE1-W	FDK28KXZE1-W	FDK36KXZE1-W	
			FDK15KXZE1	FDK22KXZE1	FDK28KXZE1	FDK36KXZE1	
Ceiling Suspended FDE					FDE36KXZE1		
Floor Standing	2way FDFW				FDFW28KXE6F		
	With Casing FDFL						
	Without Casing FDFU				FDFU28KXE6F		
OA Processing unit FDU-F		Can not be connected to the Micro KX (4-6HP), KXZ Lite.					
Air flow m <sup>3</sup> /h			150	250	350	500	
Fresh Air Assembly SAF-DX			SAF-DX250E6	SAF-DX350E6	SAF-DX500E6		
Fresh Air Ventillation and Heat Exchange unit SAF		SAF150E7	SAF250E7	SAF350E7	SAF500E7		

\*R32 indoor unit are not compatible with R410A outdoor unit and vice versa.

	4.5kW <1.6HP>	5.6kW <2HP>	7.1kW <2.5HP>	9.0kW <3.2HP>	11.2kW <4HP>	14.0kW <5HP>	16.0kW <6HP>	22.4kW <8HP>	28.0kW <10HP>
	FDT45KXZE1-W	FDT56KXZE1-W	FDT71KXZE1-W	FDT90KXZE1-W	FDT112KXZE1-W	FDT140KXZE1-W	FDT160KXZE1-W		
	FDT45KXZE1	FDT56KXZE1	FDT71KXZE1	FDT90KXZE1	FDT112KXZE1	FDT140KXZE1	FDT160KXZE1		
	FDTC45KXZE1-W	FDTC56KXZE1-W							
	FDTC45KXZE1	FDTC56KXZE1							
	FDTW45KXE6F	FDTW56KXE6F	FDTW71KXE6F	FDTW90KXE6F	FDTW112KXE6F	FDTW140KXE6F			
	FDTS45KXE6F		FDTS71KXE6F						
	FDU45KXE6F-W	FDU56KXE6F-W	FDU71KXE6F-W	FDU90KXE6F-W	FDU112KXE6F-W	FDU140KXE6F-W	FDU160KXE6F-W		
	FDU45KXE6F	FDU56KXE6F	FDU71KXE6F	FDU90KXE6F	FDU112KXE6F	FDU140KXE6F	FDU160KXE6F	FDU224KXZE1	FDU280KXZE1
	FDUM45KXE6F-W	FDUM56KXE6F-W	FDUM71KXE6F-W	FDUM90KXE6F-W	FDUM112KXE6F-W	FDUM140KXE6F-W	FDUM160KXE6F-W		
	FDUM45KXE6F	FDUM56KXE6F	FDUM71KXE6F	FDUM90KXE6F	FDUM112KXE6F	FDUM140KXE6F	FDUM160KXE6F		
	FDUT45KXE6F-W	FDUT56KXE6F-W	FDUT71KXE6F-W						
	FDUT45KXE6F-E	FDUT56KXE6F-E	FDUT71KXE6F-E						
	FDK45KXZE1-W	FDK56KXZE1-W	FDK71KXZE1-W	FDK90KXZE1-W					
	FDK45KXZE1	FDK56KXZE1	FDK71KXZE1	FDK90KXZE1					
	FDE45KXZE1	FDE56KXZE1	FDE71KXZE1		FDE112KXZE1	FDE140KXZE1			
	FDL45KXE6F	FDL56KXE6F							
			FDL71KXE6F						
	FDL45KXE6F	FDL56KXE6F	FDL71KXE6F						
				FDL650FKXZE1		FDL1100FKXZE1		FDL1800FKXZE1	FDL2400FKXZE1
		800	1000						
		SAF-DX800E6	SAF-DX1000E6						
		SAF800E7	SAF1000E7						

# Benefits Summary

When using RC-EX3D (Remote control), functions with symbol  are available. However, for RC-E5 (Remote control), functions with  are not available.

Energy Saving	<b>Inverter technology</b>	Inverter control technology delivers high efficiency and a smooth operation from high speed to low speed. A smooth sine voltage wave is attained.
	<b>Energy-saving★</b>	Since the capacity is controlled automatically based on the outdoor temperature, energy can be saved without losing comfort.
	<b>Motion sensor★</b>	This sensor detects human activity and shifts the temperature setting according to the amount of activity in the room.
	<b>Home leave operation★</b>	This function ensures that when the room is unoccupied for long periods of time, the unit will maintain a moderate indoor temperature, avoiding extremely hot or cool temperatures.
	<b>Set temperature auto return★</b>	This function allows the user to program a preferred set temperature that the unit will return to each time it is operated.
Comfort	<b>Automatic operation</b>	This function automatically selects the required heating or cooling function based on the current room conditions.
	<b>Silent operation</b>	This function allows the user to program periods where the unit will operate with reduced noise levels, perfect for night time and an uninterrupted sleep.
	<b>Hi power operation★</b>	Use the high power function to quickly reach your optimum temperature level when you first turn on the unit. This function will operate for a maximum of 15 minutes before returning to normal operation.
Air flow	<b>Flap control system</b>	This function allows the user to set the upper and lower limit positions of the flap at each air outlet individually, providing you with complete control over interior air flow.
	<b>Vertical auto swing</b>	The vertical louvers on your unit will move up and down continuously during operation. This function allows you to set the up/down swing position of the louver to the preferred operation angle.
	<b>Draft prevention setting★</b>	Draft Prevention setting provides a comfortable air flow without any draft feeling. Whether cooling or heating a room, the remote control can be used to instantly suppress any warm or cool drafts. This accurately assists how air flow is directed out of the indoor unit.
	<b>Automatic fan speed</b>	The unit's on-board microcomputer continuously monitors the room's air temperature and adjusts the air flow automatically.
Timer	<b>Sleep timer</b>	This function allows the user to set a pre-determined amount of time between 30 and 240 minutes that your unit will operate for before switching off.
	<b>Peak-cut timer★</b>	This function lets the user to preset the capacity limit during certain periods of the day, minimising energy consumption during peak billing times, thus reducing operation costs.
	<b>Weekly timer</b>	Set the unit to turn on and off automatically on a weekly basis to suit your usual room usage on each day.
Convenient	<b>Function Switch★</b>	From the eight available functions on the unit, this function allows the user to set two functions to operate automatically.
	<b>Favourite setting★</b>	Operation mode, set temperature, fan speed and air flow direction automatically adjust to the programmed favourite setting.
	<b>Static pressure adjustment</b>	This is operable when connecting duct type indoor units equipped with the external static pressure adjustment function. It will adjust the airflow accordingly based on the connected duct static pressure.
	<b>Select the language★</b>	Set the language to be displayed on the remote control.
	<b>Air filter</b>	The air filter in the unit traps and removes airborne dust particles and other allergens to provide you clean air.
	<b>Filter sign</b>	This warning alerts when the filter needs to be cleaned.
	<b>Outside air intake</b>	This function provides clean fresh air into the room through the external air intake, avoiding the constant recycling of internal air.
Others	<b>Self diagnostics</b>	The internal microcomputer automatically runs a diagnostic of the system in the event of a malfunction. This enables authorised dealers to isolate and repair any issues.
	<b>Built in drain pump</b>	The built-in drain pump, allows greater flexibility with installation, offering a great solution for applications with limited space.
	<b>Improved serviceability</b>	The fan unit (comprised of impeller and motor) is easily accessible from either the side or bottom of the unit and can be slid out for easy maintenance.





# Ceiling Cassette -4way- FDT

## Model No.

FDT28KXZE1-W	FDT28KXZE1
FDT36KXZE1-W	FDT36KXZE1
FDT45KXZE1-W	FDT45KXZE1
FDT56KXZE1-W	FDT56KXZE1
FDT71KXZE1-W	FDT71KXZE1
FDT90KXZE1-W	FDT90KXZE1
FDT112KXZE1-W	FDT112KXZE1
FDT140KXZE1-W	FDT140KXZE1
FDT160KXZE1-W	FDT160KXZE1



## Remote control (option)

Wired

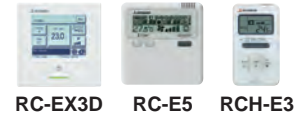

Wireless



RCN-T-5BW-E2(White)  
RCN-T-5BB-E2(Black)

\*R32 indoor unit are not compatible with R410A outdoor unit and vice versa.

## Draft Prevention Panel (Option)

### Draft Prevention Panel

(Option)

This prevents cold/hot draft being blown directly on the user. It is possible to set Draft Prevention Panel for each air outlet.

Advanced airflow control technology cultivated through aircraft development.

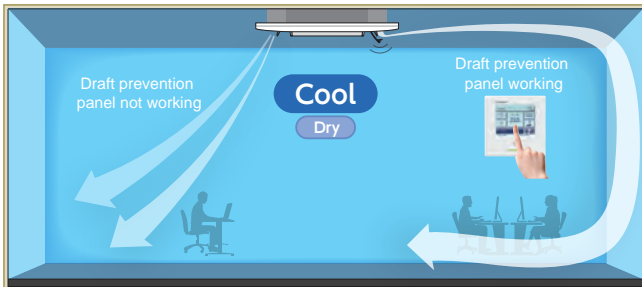

User can position panels by using the remote controller (RC-EX3D, Wireless kit) only when Draft Prevention Panel is available.

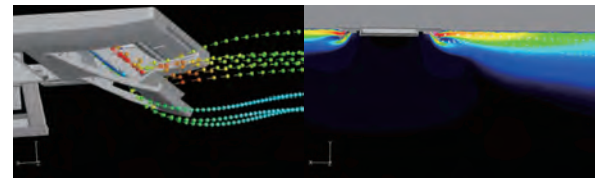

Draft Prevention Panel working

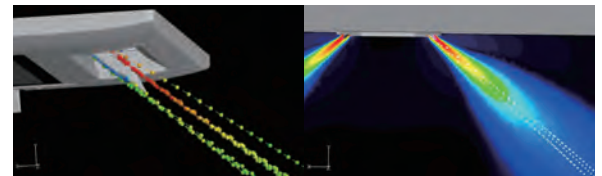

Draft Prevention Panel placed at off position

### Motion Sensor

(Option)

Motion sensor is equipped in the corner of the panel and detects the presence/absence and activity of humans in a room to improve the comfort and energy saving performance of the unit.

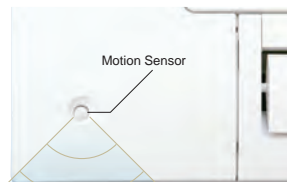

LB-T-5BW-E(White)  
LB-T-5BB-E(Black)

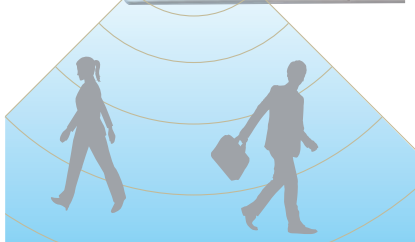

### Improve the aerodynamic performance of the unit

New designed component has better aerodynamic performance and achieve lower noise.

### New design turbo fan

### Fan guard (standard equipment)



## Panel select pattern

(Option)

8 patterns of panel are available.

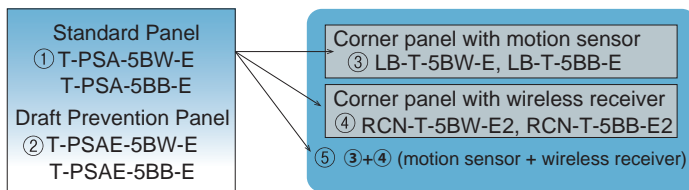

Installation position of Wireless kit and Motion sensor kit

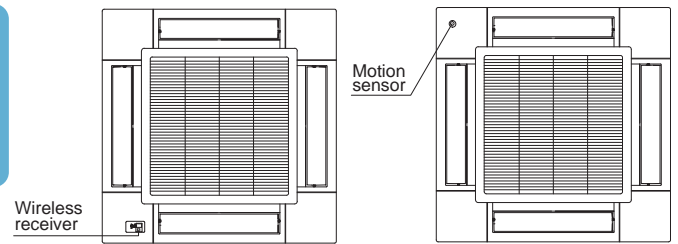

\*Wireless receiver and Motion sensor can be installed to the position as shown

- ① Standard Panel only
- ①+③ Standard Panel with corner panel with motion sensor
- ①+④ Standard Panel with corner panel with wireless receiver
- ①+⑤ Standard Panel with corner panel with motion sensor & corner panel with wireless receiver
- ② Draft Prevention Panel only
- ②+③ Draft Prevention Panel with corner panel with motion sensor
- ②+④ Draft Prevention Panel with corner panel with wireless receiver
- ②+⑤ Draft Prevention Panel with corner panel with motion sensor & corner panel with wireless receiver

## Individual flap control system

According to room conditions, four directions of air flow can be controlled individually by utilizing the flap control system. Individual flap control is available even after installation.

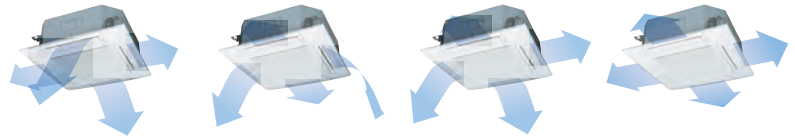

Flap can swing within an upper and lower flap range position that can be selected with a wired remote control.

\*The wireless remote control is not applicable to the Individual flap control system.

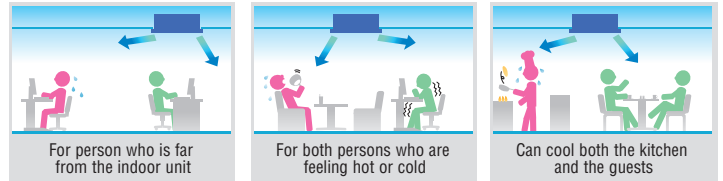
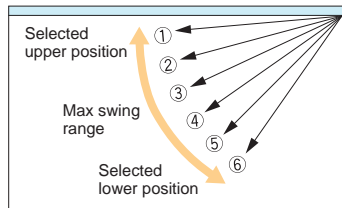

## 850mm Drain Pump

Drain can be discharged upwards up to 850mm from the ceiling surface, allowing a piping layout with a high degree of freedom. Thanks to the 185mm flexible hose, equipment supports easy workability.

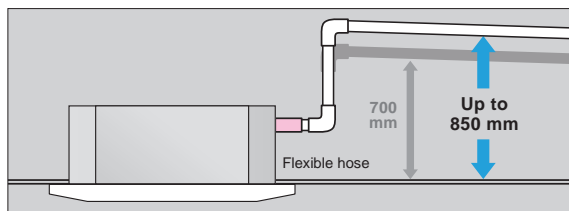

## Suitable for High ceilings

The Powerful blowout carries comfortable air flow to the floor even in high ceiling applications. It is ideal for high ceiling offices, stores, etc., with a wide, uniform air flow throughout the room.

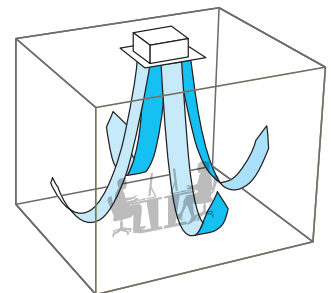

## Easy check of drain pan

Easy inspection of the condition of the drain pan is possible by removing only the corner lid.



Remove corner lid.

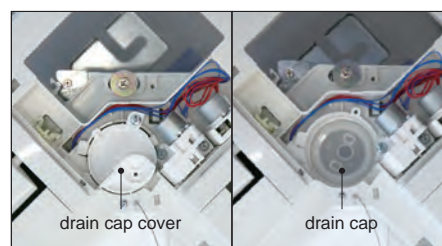

Remove drain cap cover and check the condition. It is necessary to clean-up, firstly remove the rubber stopper to drain water out and secondly remove the drain cap.

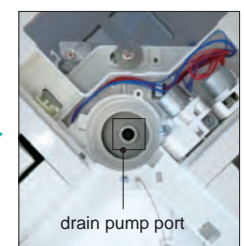

Clean up the area around the drain pump port.

# Specifications

Item	Model	FDT28KXZE1-W	FDT36KXZE1-W	FDT45KXZE1-W	FDT56KXZE1-W	FDT71KXZE1-W
Nominal cooling capacity	kW	2.8	3.6	4.5	5.6	7.1
Nominal heating capacity	kW	3.2	4.0	5.0	6.3	8.0
Power source		1 Phase 220-240V, 50Hz				
Power consumption	Cooling	0.04-0.04			0.07-0.07	0.08-0.08
	Heating	0.04-0.04			0.07-0.07	0.08-0.08
Sound power level	dB(A)	55			60	62
Sound pressure level	Cooling	P-Hi:40 Hi:32 Me:30 Lo:28	P-Hi:40 Hi:34 Me:30 Lo:28	P-Hi:40 Hi:34 Me:31 Lo:28	P-Hi:44 Hi:34 Me:31 Lo:28	P-Hi:47 Hi:35 Me:32 Lo:28
	Heating	P-Hi:40 Hi:31 Me:29 Lo:26	P-Hi:40 Hi:33 Me:29 Lo:26	P-Hi:40 Hi:33 Me:30 Lo:26	P-Hi:44 Hi:34 Me:30 Lo:27	P-Hi:47 Hi:35 Me:32 Lo:28
Exterior dimensions (H x W x D)	mm	Unit:236x840x840 Panel:35x950x950				
Net weight	kg	Unit:20 Standard Panel:5			Unit:21.5 Standard Panel:5	
Air flow	Cooling	P-Hi:20 Hi:14 Me:12 Lo:10	P-Hi:20 Hi:15 Me:12 Lo:10	P-Hi:20 Hi:15 Me:13 Lo:10	P-Hi:26 Hi:16 Me:13 Lo:11	P-Hi:28 Hi:17 Me:14 Lo:12
	Heating	P-Hi:20 Hi:14 Me:12 Lo:11	P-Hi:20 Hi:15 Me:12 Lo:11	P-Hi:20 Hi:15 Me:13 Lo:11		
Outside air intake		Possible				
Panel		T-PSA-5BW-E, T-PSAE-5BW-E (White) / T-PSA-5BB-E, T-PSAE-5BB-E (Black)				
Air filter, Q'ty		Pocket Plastic net x1 (Washable)				
Remote control (option)		wired:RC-EX3D, RC-E5, RCH-E3 wireless:RCN-T-5BW-E2, RCN-T-5BB-E2				
Installation data Refrigerant piping size	mm(in)	Liquid line:ø6.35(1/4") Gas line:ø9.52(3/8")	Liquid line:ø6.35(1/4") Gas line:ø12.7(1/2")			Liquid line:ø9.52(3/8") Gas line:ø15.88(5/8")

Item	Model	FDT90KXZE1-W	FDT112KXZE1-W	FDT140KXZE1-W	FDT160KXZE1-W
Nominal cooling capacity	kW	9.0	11.2	14.0	16.0
Nominal heating capacity	kW	10.0	12.5	16.0	18.0
Power source		1 Phase 220-240V, 50Hz			
Power consumption	Cooling	0.13-0.13		0.14-0.14	
	Heating	0.13-0.13		0.14-0.14	
Sound power level	dB(A)	65		66	
Sound pressure level	Cooling	P-Hi:49 Hi:38 Me:36 Lo:31	P-Hi:49 Hi:39 Me:37 Lo:31	P-Hi:49 Hi:42 Me:39 Lo:32	P-Hi:49 Hi:42 Me:39 Lo:32
	Heating	P-Hi:49 Hi:38 Me:36 Lo:30	P-Hi:49 Hi:39 Me:37 Lo:30	P-Hi:49 Hi:42 Me:39 Lo:31	P-Hi:49 Hi:42 Me:39 Lo:31
Exterior dimensions (H x W x D)	mm	Unit:298x840x840 Panel:35x950x950			
Net weight	kg	Unit:25 Standard Panel:5			
Air flow	Cooling	P-Hi:37 Hi:25 Me:22 Lo:15	P-Hi:38 Hi:26 Me:23 Lo:17	P-Hi:38 Hi:28 Me:25 Lo:18	P-Hi:38 Hi:29 Me:26 Lo:19
	Heating				
Outside air intake		Possible			
Panel		T-PSA-5BW-E, T-PSAE-5BW-E (White) / T-PSA-5BB-E, T-PSAE-5BB-E (Black)			
Air filter, Q'ty		Pocket Plastic net x1 (Washable)			
Remote control (option)		wired:RC-EX3D, RC-E5, RCH-E3 wireless:RCN-T-5BW-E2, RCN-T-5BB-E2			
Installation data Refrigerant piping size	mm(in)	Liquid line:ø9.52(3/8") Gas line:ø15.88(5/8")			

- The data are measured under the following conditions (ISO-T1). Cooling: Indoor temp. of 27°CDB, 19°CWB, and outdoor temp. of 35°CDB. Heating: Indoor temp. of 20°CDB, and outdoor temp. of 7°CDB, 6°CWB.
- Sound pressure level indicates the value in an anechoic chamber. During operation these values are somewhat higher due to ambient conditions.

# Specifications

Item	Model	FDT28KXZE1	FDT36KXZE1	FDT45KXZE1	FDT56KXZE1	FDT71KXZE1
Nominal cooling capacity	kW	2.8	3.6	4.5	5.6	7.1
Nominal heating capacity	kW	3.2	4.0	5.0	6.3	8.0
Power source		1 Phase 220-240V, 50Hz				
Power consumption	Cooling	0.04-0.04			0.07-0.07	0.08-0.08
	Heating	0.04-0.04			0.07-0.07	0.08-0.08
Sound power level	dB(A)	55			60	62
Sound pressure level	Cooling	P-Hi:38 Hi:33 Me:30 Lo:28		P-Hi:38 Hi:33 Me:31 Lo:29	P-Hi:44 Hi:33 Me:31 Lo:29	P-Hi:47 Hi:35 Me:32 Lo:28
	Heating					
Exterior dimensions (H x W x D)	mm	Unit:236x840x840 Panel:35x950x950				
Net weight	kg	Unit:20 Standard Panel:5			Unit:21.5 Standard Panel:5	
Air flow	Cooling	P-Hi:20 Hi:14 Me:12 Lo:10	P-Hi:20 Hi:14 Me:12 Lo:10	P-Hi:20 Hi:15 Me:13 Lo:10	P-Hi:26 Hi:16 Me:13 Lo:11	P-Hi:28 Hi:17 Me:14 Lo:12
	Heating					
Outside air intake		Possible				
Panel		T-PSA-5BW-E, T-PSAE-5BW-E (White) / T-PSA-5BB-E, T-PSAE-5BB-E (Black)				
Air filter, Q'ty		Pocket Plastic net x1 (Washable)				
Remote control (option)		wired:RC-EX3D, RC-E5, RCH-E3 wireless:RCN-T-5BW-E2, RCN-T-5BB-E2				
Installation data Refrigerant piping size	mm(in)	Liquid line:ø6.35(1/4") Gas line:ø9.52(3/8")	Liquid line:ø6.35(1/4") Gas line:ø12.7(1/2")			Liquid line:ø9.52(3/8") Gas line:ø15.88(5/8")

Item	Model	FDT90KXZE1	FDT112KXZE1	FDT140KXZE1	FDT160KXZE1
Nominal cooling capacity	kW	9.0	11.2	14.0	16.0
Nominal heating capacity	kW	10.0	12.5	16.0	18.0
Power source		1 Phase 220-240V, 50Hz			
Power consumption	Cooling	0.13-0.13		0.14-0.14	
	Heating	0.13-0.13		0.14-0.14	
Sound power level	dB(A)	65		66	
Sound pressure level	Cooling	P-Hi:49 Hi:38 Me:36 Lo:31	P-Hi:49 Hi:39 Me:37 Lo:31	P-Hi:49 Hi:42 Me:39 Lo:32	P-Hi:49 Hi:42 Me:39 Lo:33
	Heating				
Exterior dimensions (H x W x D)	mm	Unit:298x840x840 Panel:35x950x950			
Net weight	kg	Unit:25 Standard Panel:5			
Air flow	Cooling	P-Hi:37 Hi:25 Me:22 Lo:15	P-Hi:38 Hi:26 Me:23 Lo:17	P-Hi:38 Hi:28 Me:25 Lo:18	P-Hi:38 Hi:29 Me:26 Lo:19
	Heating				
Outside air intake		Possible			
Panel		T-PSA-5BW-E, T-PSAE-5BW-E (White) / T-PSA-5BB-E, T-PSAE-5BB-E (Black)			
Air filter, Q'ty		Pocket Plastic net x1 (Washable)			
Remote control (option)		wired:RC-EX3D, RC-E5, RCH-E3 wireless:RCN-T-5BW-E2, RCN-T-5BB-E2			
Installation data Refrigerant piping size	mm(in)	Liquid line:ø9.52(3/8") Gas line:ø15.88(5/8")			

- The data are measured under the following conditions (ISO-T1). Cooling: Indoor temp. of 27°CDB, 19°CWB, and outdoor temp. of 35°CDB. Heating: Indoor temp. of 20°CDB, and outdoor temp. of 7°CDB, 6°CWB.
- Sound pressure level indicates the value in an anechoic chamber. During operation these values are somewhat higher due to ambient conditions.

# Dimensions

All measurements in mm.

FDT28KXZE1-W, 36KXZE1-W, 45KXZE1-W, 56KXZE1-W, 71KXZE1-W

FDT28KXZE1, 36KXZE1, 45KXZE1, 56KXZE1, 71KXZE1

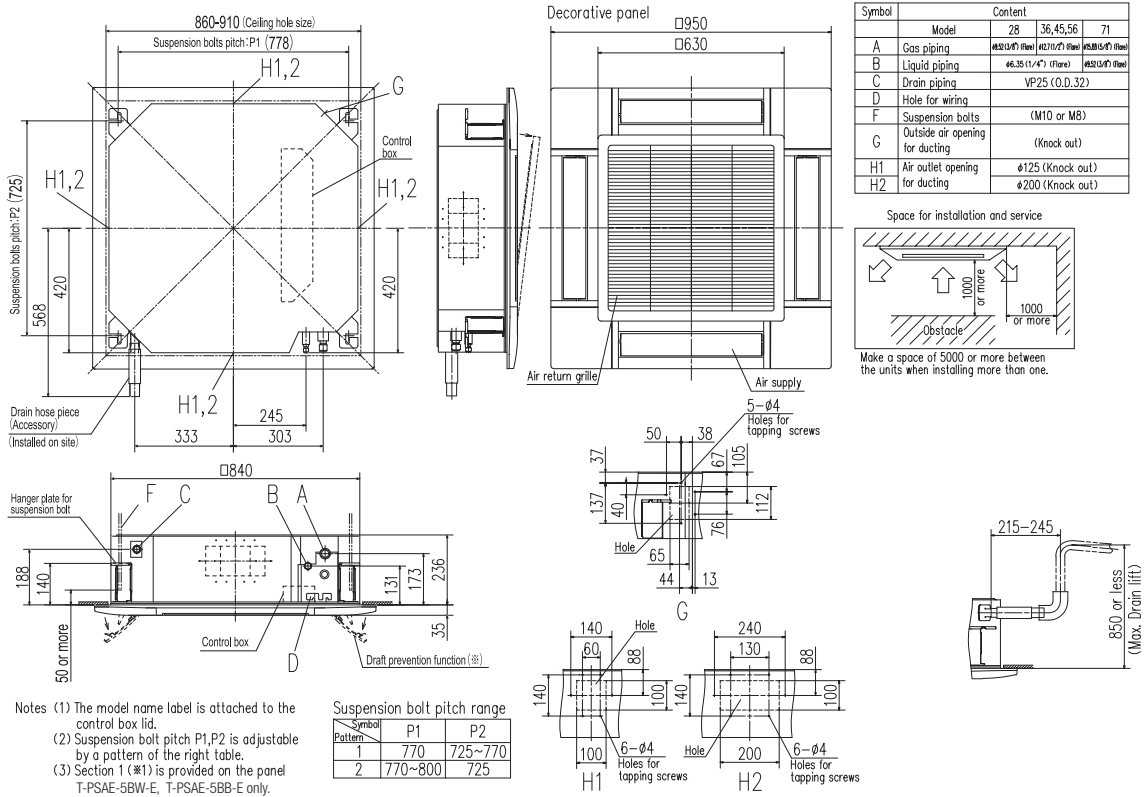

FDT90KXZE1-W, 112KXZE1-W, 140KXZE1-W, 160KXZE1-W

FDT90KXZE1, 112KXZE1, 140KXZE1, 160KXZE1

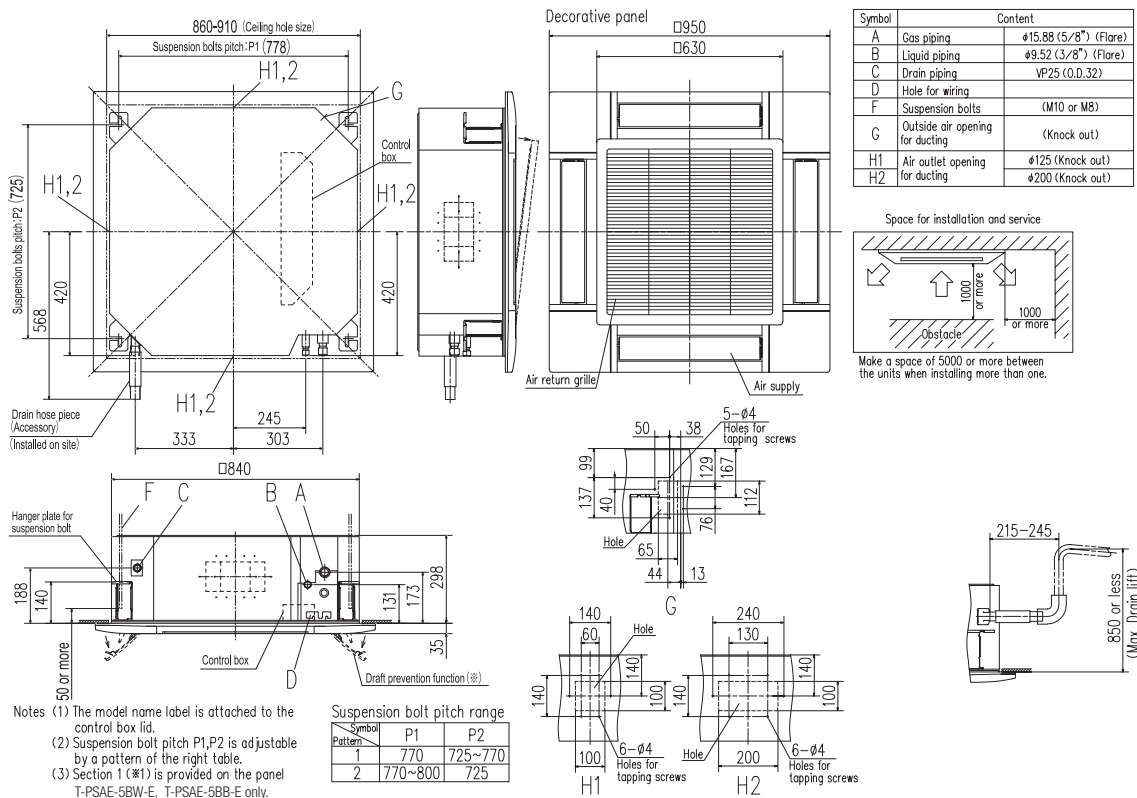



# Ceiling Cassette - 4way Compact FDTC

Model No.

- FDTC15KXZE1-W
- FDTC22KXZE1-W
- FDTC28KXZE1-W
- FDTC36KXZE1-W
- FDTC45KXZE1-W
- FDTC56KXZE1-W

- FDTC15KXZE1
- FDTC22KXZE1
- FDTC28KXZE1
- FDTC36KXZE1
- FDTC45KXZE1
- FDTC56KXZE1



**Draft Prevention Panel (option)**



**Grid type**

## Remote control (option)

Wired



**RC-EX3D RC-E5 RCH-E3**

Wireless



**RCN-TC-5AW-E3**

\*R32 indoor unit are not compatible with R410A outdoor unit and vice versa.

## European design & Flat panel

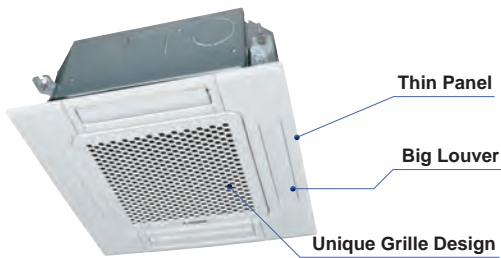

### Unique Grille Design

A grille designed with a unique structure and a clean white panel that blends with the room.



**Honeycomb type**



**Grid type**

### Integrated ceiling system design 600x600



Easy installation - with a weight of only 14kg, a thin panel, and a main body size of only 248mm.

### Taking OA (Outside Air) into inside

Fresh air can be taken in without optional parts. When the fresh air is insufficient, optional parts can be used.

- OA Spacer TC-OAS-E2(option)
- Joint Duct TC-OAD-E(option)

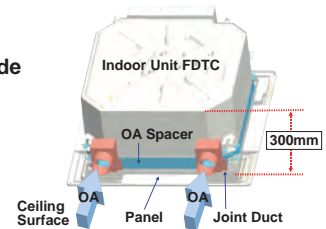

### Draft Prevention Panel (Option)

This prevents cold/hot draft being blown directly on the user. It is possible to set Draft Prevention Panel for each air outlet.

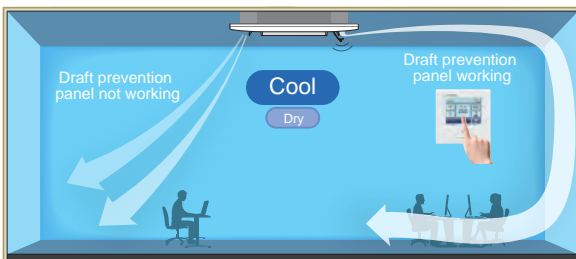

User can position panels by using the remote controller (RC-EX3D, Wireless kit) only when Draft Prevention Panel is available.

### Motion Sensor (Option)

Motion sensor is equipped in the corner of the panel and detects the presence/absence and activity of humans in a room to improve the comfort and energy saving performance of the unit.



**LB-TC-5W-E**

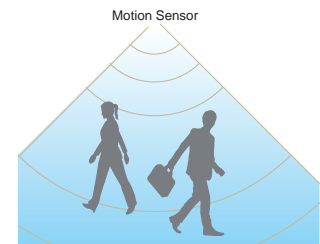

## Panel select pattern

(Option)

8 patterns of panel are available.

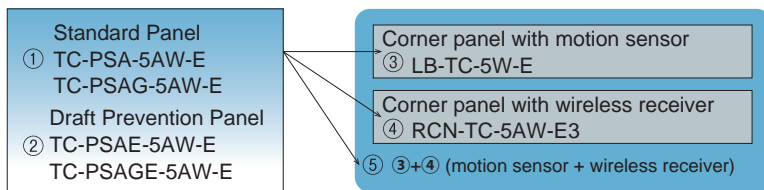

- ① Standard Panel only
- ①+③ Standard Panel with corner panel with motion sensor
- ①+④ Standard Panel with corner panel with wireless receiver
- ①+⑤ Standard Panel with corner panel with motion sensor & corner panel with wireless receiver
- ② Draft Prevention Panel only
- ②+③ Draft Prevention Panel with corner panel with motion sensor
- ②+④ Draft Prevention Panel with corner panel with wireless receiver
- ②+⑤ Draft Prevention Panel with corner panel with motion sensor & corner panel with wireless receiver

## Individual flap control system

According to room temperature conditions, four directions of air flow can be controlled individually by following Flap control system. Individual flap control is available even after installation.

The flap can swing within the range of upper and lower flap position selected with wired remote control.

※The wireless remote control is not applicable to the Individual flap control system.

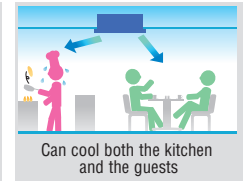
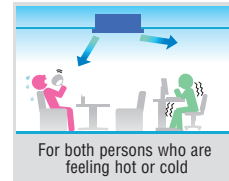
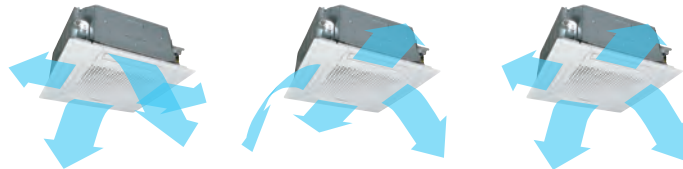
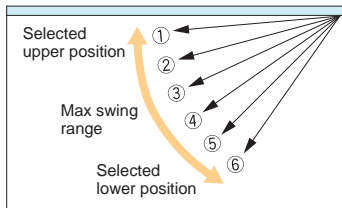

## 850mm Drain Pump

Drain can be discharged upward by 850 mm from the ceiling surface close to the indoor unit. It allows a piping layout with a high degree of freedom depending on the installation location.

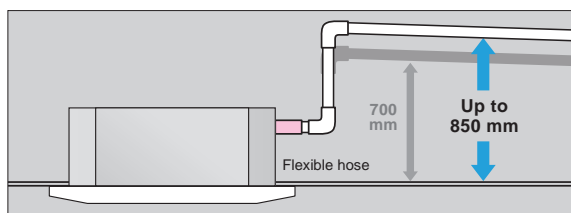

## Suitable for High ceilings

The Powerful blowout carries comfortable air flow to the floor even in high ceiling applications. It is ideal for high ceiling offices, stores, etc., with a wide, uniform air flow throughout the room.

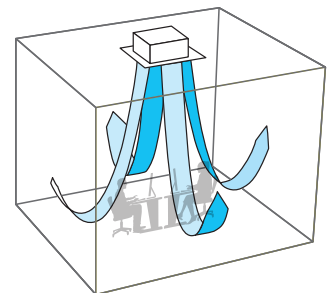

# Specifications



Item	Model	FDTC15KXZE1-W	FDTC22KXZE1-W	FDTC28KXZE1-W	FDTC36KXZE1-W	FDTC45KXZE1-W	FDTC56KXZE1-W
Nominal cooling capacity	kW	1.5	2.2	2.8	3.6	4.5	5.6
Nominal heating capacity	kW	1.7	2.5	3.2	4.0	5.0	6.3
Power source		1 Phase 220-240V, 50Hz					
Power consumption	Cooling	0.03-0.03			0.04-0.04	0.05-0.05	0.06-0.06
	Heating	0.03-0.03			0.04-0.04	0.05-0.05	0.06-0.06
Sound power level	dB(A)	Cooling:47 Heating:46	49		Cooling:54 Heating:53	Cooling:58 Heating:57	60
Sound pressure level	Cooling	P-Hi:33 Hi:30 Me:28 Lo:25		P-Hi:35 Hi:32 Me:29 Lo:25		P-Hi:39 Hi:36 Me:31 Lo:26	
	Heating	P-Hi:33 Hi:30 Me:26 Lo:22				P-Hi:43 Hi:39 Me:36 Lo:28	
Exterior dimensions (H x W x D)	mm	Unit:248x570x570 Panel:10x620x620					
Net weight	kg	Unit:12.5 Standard Panel:2.5	Unit:13 Standard Panel:2.5		Unit:14 Standard Panel:2.5		
Air flow	Cooling	P-Hi:8 Hi:7 Me:6 Lo:5		P-Hi:9 Hi:8 Me:7 Lo:6		P-Hi:10 Hi:9 Me:8 Lo:6	
	Heating					P-Hi:12 Hi:10 Me:9 Lo:7	
Outside air intake		Possible					
Panel		TC-PSA-5AW-E, TC-PSAE-5AW-E (Honeycomb) / TC-PSAG-5AW-E, TC-PSAGE-5AW-E (Grid)					
Air filter, Q'ty		Pocket Plastic net x1 (Washable)					
Remote control (option)		wired:RC-EX3D, RC-E5, RCH-E3 wireless:RCN-TC-5AW-E3					
Installation data Refrigerant piping size	mm(in)	Liquid line:ø6.35(1/4") Gas line:ø9.52(3/8")			Liquid line:ø6.35(1/4") Gas line:ø12.7(1/2")		

- The data are measured under the following conditions(ISO-T1). Cooling: Indoor temp. of 27°CDB, 19°CWB, and outdoor temp. of 35°CDB. Heating: Indoor temp. of 20°CDB, and outdoor temp. of 7°CDB, 6°CWB.
- Sound pressure level indicates the value in an anechoic chamber. During operation these values are somewhat higher due to ambient conditions.

# Specifications



Item	Model	FDTC15KXZE1	FDTC22KXZE1	FDTC28KXZE1	FDTC36KXZE1	FDTC45KXZE1	FDTC56KXZE1
Nominal cooling capacity	kW	1.5	2.2	2.8	3.6	4.5	5.6
Nominal heating capacity	kW	1.7	2.5	3.2	4.0	5.0	6.3
Power source		1 Phase 220-240V, 50Hz					
Power consumption	Cooling	0.03-0.03			0.04-0.04	0.05-0.05	0.06-0.06
	Heating	0.03-0.03			0.04-0.04	0.05-0.05	0.06-0.06
Sound power level	dB(A)	Cooling:47 Heating:46	49		Cooling:54 Heating:53	Cooling:58 Heating:57	60
Sound pressure level	Cooling	P-Hi:33 Hi:30 Me:28 Lo:25		P-Hi:35 Hi:32 Me:29 Lo:25		P-Hi:39 Hi:36 Me:31 Lo:26	
	Heating	P-Hi:33 Hi:30 Me:26 Lo:22				P-Hi:43 Hi:39 Me:36 Lo:28	
Exterior dimensions (H x W x D)	mm	Unit:248x570x570 Panel:10x620x620					
Net weight	kg	Unit:12.5 Standard Panel:2.5	Unit:13 Standard Panel:2.5		Unit:14 Standard Panel:2.5		
Air flow	Cooling	P-Hi:8 Hi:7 Me:6 Lo:5		P-Hi:9 Hi:8 Me:7 Lo:6		P-Hi:10 Hi:9 Me:8 Lo:6	
	Heating					P-Hi:12 Hi:10 Me:9 Lo:7	
Outside air intake		Possible					
Panel		TC-PSA-5AW-E, TC-PSAE-5AW-E (Honeycomb) / TC-PSAG-5AW-E, TC-PSAGE-5AW-E (Grid)					
Air filter, Q'ty		Pocket Plastic net x1 (Washable)					
Remote control (option)		wired:RC-EX3D, RC-E5, RCH-E3 wireless:RCN-TC-5AW-E3					
Installation data Refrigerant piping size	mm(in)	Liquid line:ø6.35(1/4") Gas line:ø9.52(3/8")			Liquid line:ø6.35(1/4") Gas line:ø12.7(1/2")		

- The data are measured under the following conditions(ISO-T1). Cooling: Indoor temp. of 27°CDB, 19°CWB, and outdoor temp. of 35°CDB. Heating: Indoor temp. of 20°CDB, and outdoor temp. of 7°CDB, 6°CWB.
- Sound pressure level indicates the value in an anechoic chamber. During operation these values are somewhat higher due to ambient conditions.



# Dimensions

All measurements in mm.

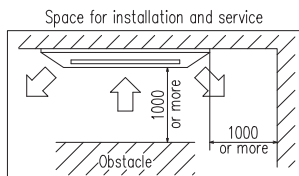
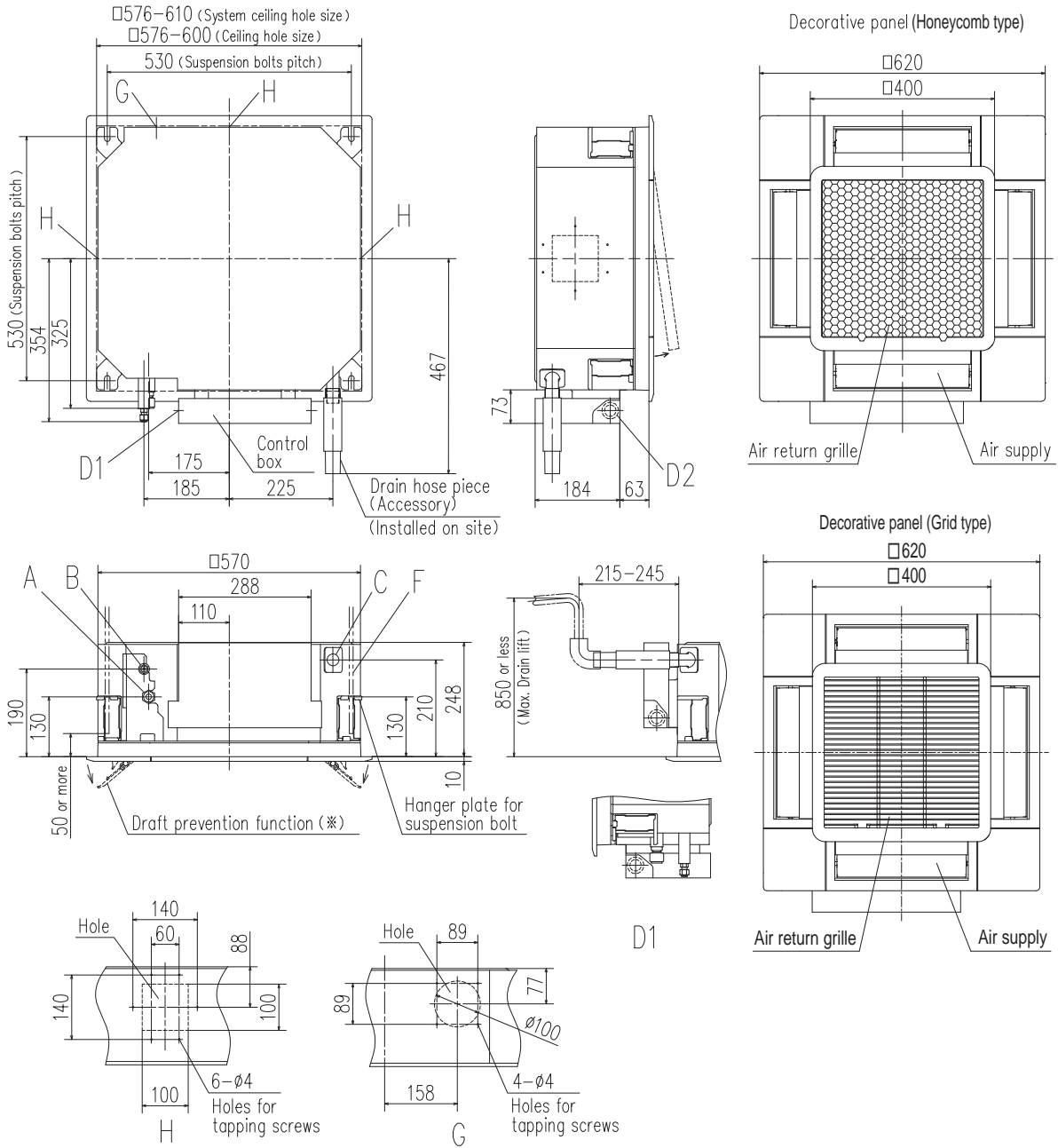

Make a space of 4000 or more between the units when installing more than one.

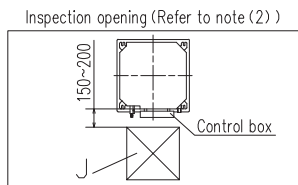

- Notes (1) The model name label is attached to the control box lid.  
 (2) This unit is designed for 2x2 grid ceiling.  
 If it is installed on a ceiling other than 2x2 grid ceiling, provide an inspection opening on the control box side.  
 (3) Draft prevention function (※) is provided on the panel TC-PSAE-5AW-E, TC-PSAGE-5AW-E only.

Symbol	Content		
	Model	15,22,28	36,45,56
A	Gas piping	φ9.52 (3/8") (Flare)	φ12.7 (1/2") (Flare)
B	Liquid piping	φ6.35 (1/4") (Flare)	
C	Drain piping	VP25 (O.D.32)	
D1	Power source connection		
D2	Remote control code and signal wiring connection		
F	Suspension bolts	(M10 or M8)	
G	Outside air opening for ducting	(Knock out)	
H	Air outlet opening for ducting	φ125 (Knock out)	
J	Inspection opening	450X450	

# Ceiling Cassette -2way- FDTW

## Model No.

FDTW28KXE6F      FDTW90KXE6F  
 FDTW45KXE6F      FDTW112KXE6F  
 FDTW56KXE6F      FDTW140KXE6F  
 FDTW71KXE6F



## Remote control (option)

Wired



RC-EX3D   RC-E5   RCH-E3

Wireless



RCN-TW-E2

## Individual flap control system

We've optimised our outlet design with advanced technology to allow you to control up to four directions of air flow. Allowing you to control air direction via the flap systems and room temperature.

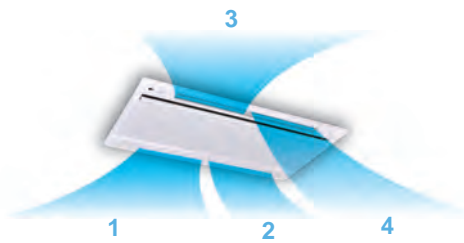

The flap can swing within the range of upper and lower flap position selected with wired control.

\*The wireless remote control is not applicable with the individual flap control system.

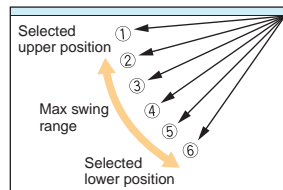

## Installation workability

### Drainage spout

Drainage flow test can be done easily by use of this drainage spout.



### Transparent access hole to drain pan

Condition of the bottom of a drain pan can be checked through this transparent access hole without removing drain pan.

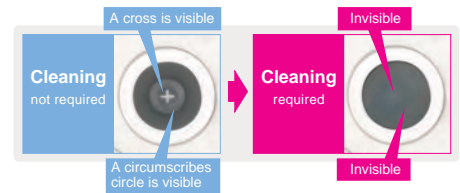

## Motion Sensor

(Option)

Motion sensor is equipped in the corner of the panel and detects the presence/absence and activity of humans in a room to improve the comfort and energy saving performance of the unit.



LB-TW-6W

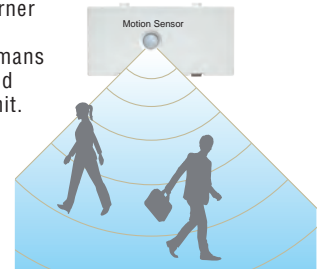

## Specifications

Item	Model	FDTW28KXE6F	FDTW45KXE6F	FDTW56KXE6F	FDTW71KXE6F	FDTW90KXE6F	FDTW112KXE6F	FDTW140KXE6F	
Nominal cooling capacity	kW	2.8	4.5	5.6	7.1	9.0	11.2	14.0	
Nominal heating capacity	kW	3.2	5.0	6.3	8.0	10.0	12.5	16.0	
Power source		1 Phase 220-240V, 50Hz							
Power consumption	Cooling	0.09-0.09	0.10-0.10		0.14-0.14		0.19-0.19		
	Heating	0.09-0.09	0.10-0.10		0.14-0.14		0.19-0.19		
Sound power level	dB(A)	58					65		
Sound pressure level	dB(A)	P-Hi:42 Hi:38 Me:34 Lo:31					P-Hi:48 Hi:45 Me:41 Lo:37		
Exterior dimensions H x W x D	mm	Unit:325x820x620 Panel:20x1120x680				Unit:325x1535x620 Panel:20x1835x680			
Net weight	kg	Unit:20 Panel:8.5	Unit:21 Panel:8.5		Unit:23 Panel:8.5		Unit:35 Panel:13		
Air flow	m <sup>3</sup> /min	P-Hi:14.5 Hi:12 Me:10 Lo:9				P-Hi:31 Hi:27 Me:23 Lo:20			
Outside air intake		Possible							
Panel		TW-PSA-26W-E				TW-PSA-46W-E			
Air filter, Q'ty		Pocket Plastic net x2 (Washable)				Pocket Plastic net x3 (Washable)			
Remote control(option)		wired:RC-EX3D, RC-E5, RCH-E3 wireless:RCN-TW-E2							
Installation data		Liquid line:ø6.35(1/4") Gas line:ø9.52(3/8")		Liquid line:ø6.35(1/4") Gas line:ø12.7(1/2")		Liquid line:ø9.52(3/8") Gas line:ø15.88(5/8")			

1. The data are measured under the following conditions(SO-T1). Cooling: Indoor temp. of 27°CDB, 19°CWB, and outdoor temp. of 35°CDB. Heating: Indoor temp. of 20°CDB, and outdoor temp. of 7°CDB, 6°CWB.  
 2. Sound pressure level indicates the value in an anechoic chamber. During operation these values are somewhat higher due to ambient conditions.

# Dimensions

All measurements in mm.

## FDTW28KXE6F, 45KXE6F, 56KXE6F, 71KXE6F

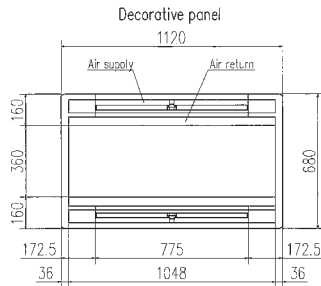
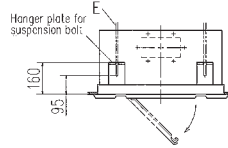
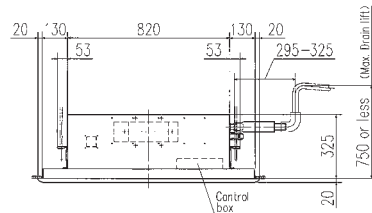
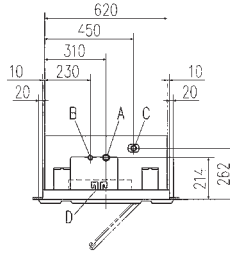
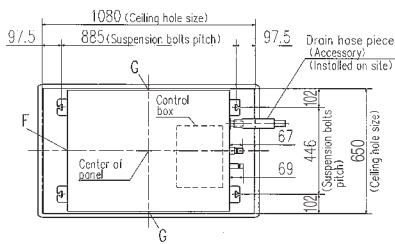

Symbol	Model	28	45.56	71
A	Gas piping	φ9.52 (3/8") (Flare)	φ12.7 (1/2") (Flare)	φ15.88 (5/8") (Flare)
B	Liquid piping	φ6.35 (1/4") (Flare)	φ9.52 (3/8") (Flare)	φ12.7 (1/2") (Flare)
C	Drain piping	VP25 (O.D. 32)		
D	Hole for wiring			
E	Suspension bolts	(M10)		
F	Outside air opening for ducting	(Knock out)		
G	Air outlet opening for ducting	(Knock out)		

Notes (1) The model name label is attached on the lid of the control box.

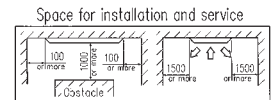

Make a space of 4000 or more between the units when installing more than one.

## FDTW90KXE6F, 112KXE6F, 140KXE6F

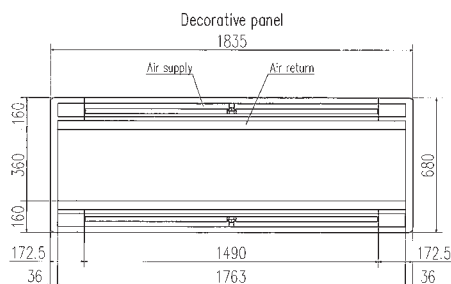
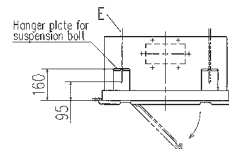
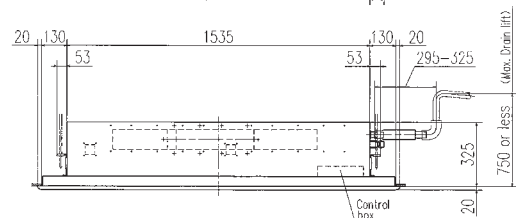
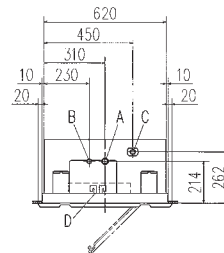
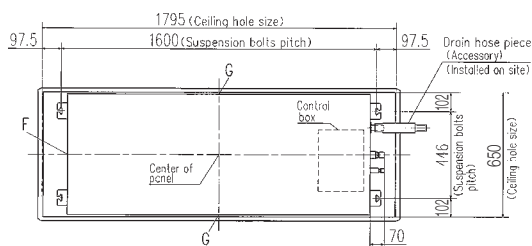

Symbol	Content
A	Gas piping φ15.88 (5/8") (Flare)
B	Liquid piping φ9.52 (3/8") (Flare)
C	Drain piping VP25 (O.D. 32)
D	Hole for wiring
E	Suspension bolts (M10)
F	Outside air opening for ducting (Knock out)
G	Air outlet opening for ducting (Knock out)

Notes (1) The model name label is attached on the lid of the control box.

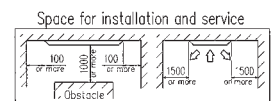

Make a space of 5000 or more between the units when installing more than one.

# Ceiling Cassette -1way- FDTS

## Model No.

FDTS45KXE6F  
FDTS71KXE6F



## Remote control (option)

Wired



RC-EX3D RC-E5 RCH-E3

Wireless



RCN-TS-E2

### Individual flap control system

Two directions of air flow can be controlled individually by flap control system.



The flap can swing within the range of upper and lower flap position selected with wired remote control.

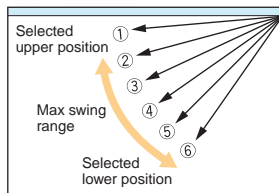

\*The wireless remote control is not applicable to the individual flap control system.

### Wireless remote control

For wireless remote control simply attach an additional panel with infrared receiver on the right side of the main decorative panel.

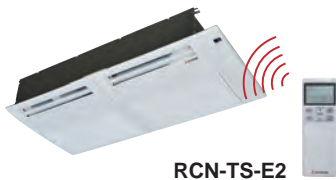

RCN-TS-E2

### Compact design

Indoor unit size (W:1150 x D:565) brings easy installation for 1200 x 600 ceiling and Panel size (1250 x 650) is suitable for 1200 x 600 ceiling. Height is the industry's lowest height level 220mm and weight is only 27, 28kg.

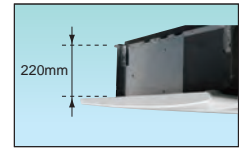

### Motion Sensor

(Option)

Motion sensor is equipped in the ceiling plane or wall plane and detects the presence/absence and activity of humans in a room to improve the comfort and energy saving performance of the unit.

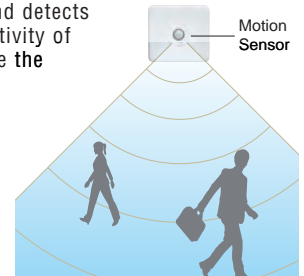

LB-KIT2

### 600mm Drain Pump

Drain can be discharged upward by 600mm from the ceiling surface close to the indoor unit. It allows a piping layout with a high degree of freedom depending on the installation location.

## Specifications

Item	Model	FDTS45KXE6F	FDTS71KXE6F
Nominal cooling capacity	kW	4.5	7.1
Nominal heating capacity	kW	5.0	8.0
Power source		1 Phase 220-240V, 50Hz	
Power consumption	Cooling	0.04-0.04	0.09-0.09
	Heating	0.04-0.04	0.09-0.09
Sound power level	dB(A)	60	61
Sound pressure level	dB(A)	P-Hi:42 Hi:40 Me:38 Lo:35	P-Hi:49 Hi:46 Me:41 Lo:36
Exterior dimensions H x W x D	mm	Unit:220x1150x565 Panel:35x1250x650	
Net weight	kg	Unit:27 Panel:5	Unit:28 Panel:5
Air flow	m <sup>3</sup> /min	P-Hi:13 Hi:12 Me:11 Lo:9.5	P-Hi:17 Hi:15 Me:12 Lo:10
Outside air intake		Possible	
Panel		TS-PSA-3AW-E	
Air filter, Q'ty		Pocket Plastic net x2 (Washable)	
Remote control(option)		wired:RC-EX3D, RC-E5, RCH-E3 wireless:RCN-TS-E2	
Installation data	mm(in)	Liquid line:ø6.35(1/4") Gas line:ø12.7(1/2")	Liquid line:ø9.52(3/8") Gas line:ø15.88(5/8")

1. The data are measured under the following conditions(SO-T1). Cooling: Indoor temp. of 27°CDB, 19°CWB, and outdoor temp. of 35°CDB. Heating: Indoor temp. of 20°CDB, and outdoor temp. of 7°CDB, 6°CWB.  
2. Sound pressure level indicates the value in an anechoic chamber. During operation these values are somewhat higher due to ambient conditions.

# Dimensions

All measurements in mm.

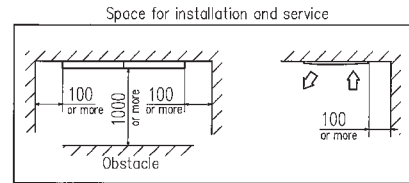
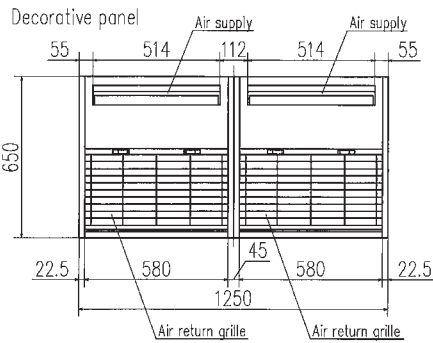
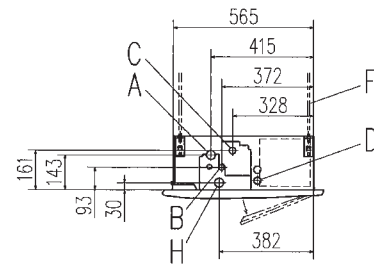
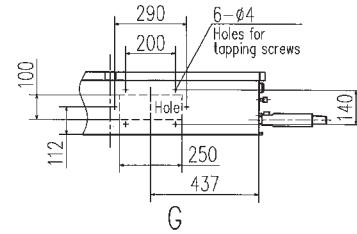
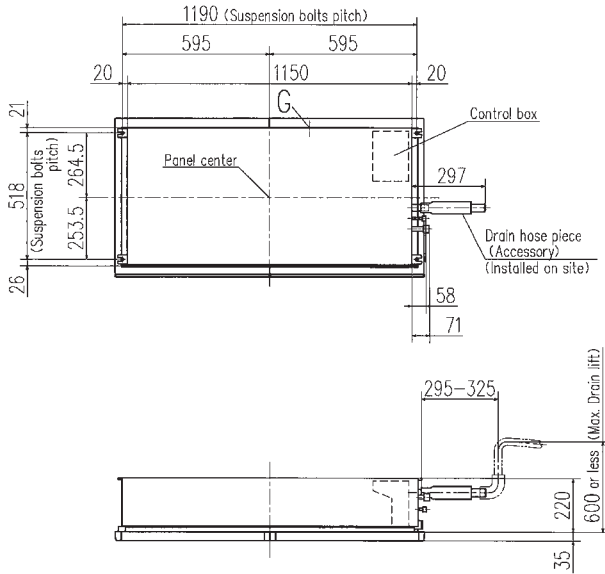

Make a space of 4000 or more between the units when installing more than one.

Symbol	Content		
	Model	45	71
A	Gas piping	ø12.7 (1/2") (Flare)	ø15.88 (5/8") (Flare)
B	Liquid piping	ø6.35 (1/4") (Flare)	ø9.52 (3/8") (Flare)
C	Drain piping	VP25 (O.D.32)	
D	Hole for wiring		
F	Suspension bolts	(M10)	
G	Outside air opening for ducting	(Knock out)	
H	Drain piping (Gravity drainage)	VP25 (I.D.25 , O.D.32)	



# Ceiling Cassette -1way Compact-FDTQ

## Model No.

FDTQ22KXE6F  
FDTQ28KXE6F  
FDTQ36KXE6F



Fits into standard  
600 x 600 ceiling

## Remote control (option)

Wired



RC-EX3D RC-E5 RCH-E3

Wireless



RCN-KIT4-E2

## Compact design

- Comfortable effective cooling for small rooms, with low fan speed air flow at just 5.4m<sup>3</sup>/min.



Optional wide panel shown for solid ceiling

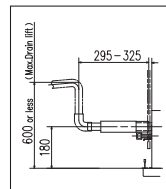

Condensate drain pump included as standard

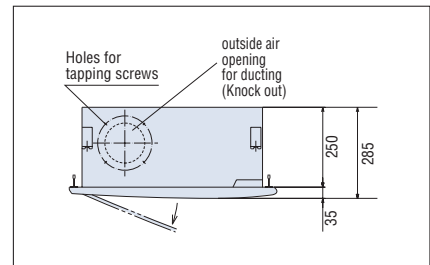

Ultra slim design at just 250mm above the ceiling

## Motion Sensor

(Option)

Motion sensor is equipped in the ceiling plane or wall plane and detects the presence/absence and activity of humans in a room to improve the comfort and energy saving performance of the unit.



LB-KIT2

## Specifications

Item	Model	FDTQ22KXE6F		FDTQ28KXE6F		FDTQ36KXE6F	
Panel Name		Direct blow panel		Direct blow panel		Direct blow panel	
Panel mode (Option)		TQ-PSA-15W-E	TQ-PSB-15W-E	TQ-PSA-15W-E	TQ-PSB-15W-E	TQ-PSA-15W-E	TQ-PSB-15W-E
Nominal cooling capacity	kW	2.2		2.8		3.6	
Nominal heating capacity	kW	2.5		3.2		4.0	
Power source		1 Phase 220-240V, 50Hz					
Power consumption	Cooling	0.05-0.07		0.05-0.07		0.05-0.07	
	Heating	0.05-0.07		0.05-0.07		0.05-0.07	
Sound power level	dB(A)	60					
Sound pressure level	dB(A)	P-Hi:45Hi:41 Me:38 Lo:33		P-Hi:45 Hi:41 Me:38 Lo:33		P-Hi:45 Hi:41 Me:38 Lo:33	
Exterior dimensions H x W x D	Unit	250x570x570		250x570x570		250x570x570	
	Panel	35x625x650	35x780x650	35x625x650	35x780x650	35x625x650	35x780x650
Net weight	kg	Unit:19 Panel:2.5	Unit:19 Panel:3	Unit:19 Panel:2.5	Unit:19 Panel:3	Unit:19 Panel:2.5	Unit:19 Panel:3
Air flow	m <sup>3</sup> /min	P-Hi:8 Hi:7 Me:6 Lo:5		P-Hi:8 Hi:7 Me:6 Lo:5		P-Hi:8 Hi:7 Me:6 Lo:5	
Outside air intake		Possible					
Air filter, Q'ty		Pocket Plastic net x1 (Washable)					
Remote control(option)		wired:RC-EX3D, RC-E5, RCH-E3 wireless:RCN-KIT4-E2					
Installation data Refrigerant piping size	mm(in)	Liquid line:ø6.35(1/4") Gas line:ø9.52(3/8")				Liquid line:ø6.35(1/4") Gas line:ø12.7(1/2")	

1. The data are based on the following conditions(ISO-T1). Cooling: Indoor temp. of 27°CDB, 19°CWB, and outdoor temp. of 35°CDB. Heating: Indoor temp. of 20°CDB, and outdoor temp. of 7°CDB, 6°CWB.  
2. Sound pressure level indicates the value in an anechoic chamber. During operation these values are somewhat higher due to ambient conditions.



# Duct Connected -High Static Pressure- FDU

## Model No.

FDU45KXE6F-W	FDU45KXE6F
FDU56KXE6F-W	FDU56KXE6F
FDU71KXE6F-W	FDU71KXE6F
FDU90KXE6F-W	FDU90KXE6F
FDU112KXE6F-W	FDU112KXE6F
FDU140KXE6F-W	FDU140KXE6F
FDU160KXE6F-W	FDU160KXE6F



FDU 45-160



FDU 224-280

## Model No.

FDU224KXZE1
FDU280KXZE1

\*R32 indoor unit are not compatible with R410A outdoor unit and vice versa.

### External Static Pressure(E.S.P) control

Manually set the E.S.P on the wired controller, and the indoor unit will control the fan speed to keep rated air flow volume at each fan speed setting. You can set a required E.S.P by your wired remote controller – calculated with the set air flow rate and the pressure loss of the duct.



**E.S.P. button** RC-E5  
External Static Pressure (E.S.P.) can be set by E.S.P. button.

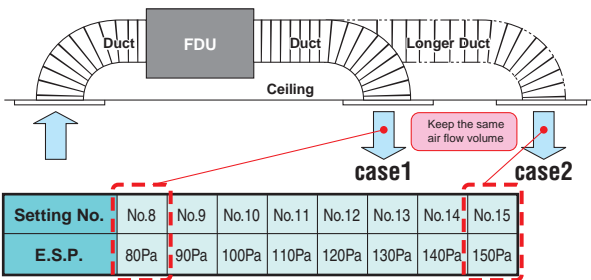

\*Range of 80-150 Pa is set at ex-factory default.  
Range of 10-200 Pa is available by setting SW8-4 switch on at site.

### Motion Sensor

(Option)

Motion sensor is equipped in the ceiling plane or wall plane and detects the presence/absence and activity of humans in a room to improve the comfort and energy saving performance of the unit.



LB-KIT2

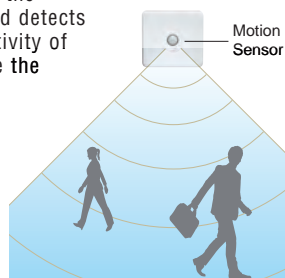

### Remote control (option)

Wired



RC-EX3D RC-E5 RCH-E3

Wireless



RCN-KIT4-E2

### Thin design

The height of FDU(45 – 160) models are only 280mm

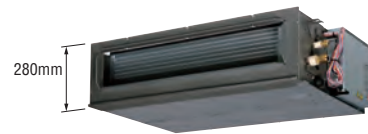

### Reduction of sound pressure level

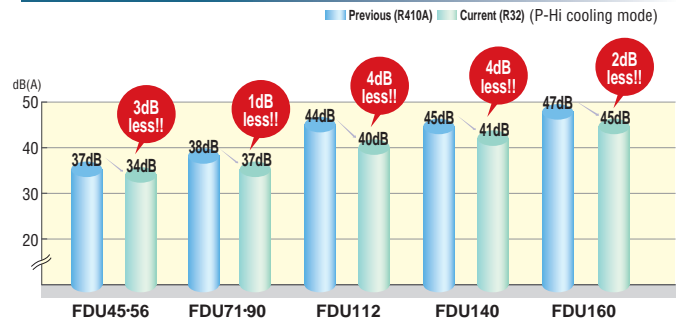

### Transparent inspection window

Dirt condition of the bottom of the drain pan can be checked through this transparent inspection window without removing drain pan. (Please refer to P88)

### Improvement of the serviceability

Fan unit (impeller and motor) can be pulled out from the right side of the unit. Maintenance can be carried out from the right side or the bottom side of the unit.

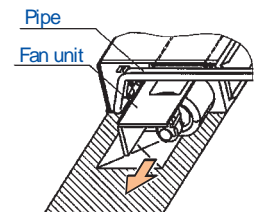

# Specifications

Item	Model	FDU45KXE6F-W	FDU56KXE6F-W	FDU71KXE6F-W	FDU90KXE6F-W	FDU112KXE6F-W	FDU140KXE6F-W	FDU160KXE6F-W
Nominal cooling capacity	kW	4.5	5.6	7.1	9.0	11.2	14.0	16.0
Nominal heating capacity	kW	5.0	6.3	8.0	10.0	12.5	16.0	18.0
Power source		1 Phase 220-240V, 50Hz						
Power consumption	Cooling	0.10-0.10		0.24-0.25		0.31-0.32	0.35-0.36	0.42-0.43
	Heating	0.10-0.10		0.24-0.25		0.31-0.32	0.35-0.36	0.42-0.43
Sound power level	dB(A)	Cooling:58 Heating:60		Cooling:63 Heating:65		Cooling:68	Heating:69	72
Sound pressure level	Cooling	P-Hi:34 Hi:29 Me:27 Lo:25		P-Hi:37 Hi:31 Me:27 Lo:22		P-Hi:40 Hi:36 Me:34 Lo:28	P-Hi:41 Hi:37 Me:34 Lo:28	P-Hi:45 Hi:38 Me:34 Lo:29
	Heating	P-Hi:35 Hi:30 Me:29 Lo:25		P-Hi:39 Hi:33 Me:28 Lo:23		P-Hi:41 Hi:36 Me:34 Lo:28	P-Hi:41 Hi:37 Me:34 Lo:28	P-Hi:45 Hi:38 Me:34 Lo:29
Exterior dimensions (H x W x D)	mm	280x750x635		280x950x635		280x1368x740		
Net weight	kg	29		34		54		
Air flow	m <sup>3</sup> /min	P-Hi:13 Hi:10 Me:9 Lo:8		P-Hi:24 Hi:19 Me:15 Lo:10		P-Hi:36 Hi:28 Me:25 Lo:19	P-Hi:39 Hi:32 Me:26 Lo:20	P-Hi:48 Hi:35 Me:28 Lo:22
Maximum external static pressure	Pa	200						
Outside air intake		Possible						
Air filter, Q'ty		Procure locally						
Remote control (option)		wired:RC-EX3D, RC-E5, RCH-E3 wireless:RCN-KIT4-E2						
Installation data Refrigerant piping size	mm(in)	Liquid line:ø6.35(1/4") Gas line:ø12.7(1/2")		Liquid line:ø9.52(3/8") Gas line:ø15.88(5/8")				

- The data are measured under the following conditions(ISO-T1). Cooling: Indoor temp. of 27°CDB, 19°CWB, and outdoor temp. of 35°CDB. Heating: Indoor temp. of 20°CDB, and outdoor temp. of 7°CDB, 6°CWB.
- Sound pressure level indicates the value in an anechoic chamber. During operation these values are somewhat higher due to ambient conditions.

# Specifications

Item	Model	FDU45KXE6F	FDU56KXE6F	FDU71KXE6F	FDU90KXE6F	FDU112KXE6F	FDU140KXE6F	FDU160KXE6F
Nominal cooling capacity	kW	4.5	5.6	7.1	9.0	11.2	14.0	16.0
Nominal heating capacity	kW	5.0	6.3	8.0	10.0	12.5	16.0	18.0
Power source		1 Phase 220-240V, 50Hz						
Power consumption	Cooling	0.10-0.10		0.24-0.25		0.31-0.32	0.35-0.36	0.42-0.43
	Heating	0.10-0.10		0.24-0.25		0.31-0.32	0.35-0.36	0.42-0.43
Sound power level	dB(A)	60		65		71	72	74
Sound pressure level	dB(A)	P-Hi:37 Hi:32 Me:29 Lo:26		P-Hi:38 Hi:33 Me:29 Lo:25		P-Hi:44 Hi:38 Me:36 Lo:30	P-Hi:45 Hi:40 Me:34 Lo:29	P-Hi:47 Hi:40 Me:35 Lo:30
Exterior dimensions (H x W x D)	mm	280x750x635		280x950x635		280x1368x740		
Net weight	kg	29		34		54		
Air flow	m <sup>3</sup> /min	P-Hi:13 Hi:10 Me:9 Lo:8		P-Hi:24 Hi:19 Me:15 Lo:10		P-Hi:36 Hi:28 Me:25 Lo:19	P-Hi:39 Hi:32 Me:26 Lo:20	P-Hi:48 Hi:35 Me:28 Lo:22
Maximum external static pressure	Pa	200						
Outside air intake		Possible						
Air filter, Q'ty		Procure locally						
Remote control (option)		wired:RC-EX3D, RC-E5, RCH-E3 wireless:RCN-KIT4-E2						
Installation data Refrigerant piping size	mm(in)	Liquid line:ø6.35(1/4") Gas line:ø12.7(1/2")		Liquid line:ø9.52(3/8") Gas line:ø15.88(5/8")				

Item	Model	FDU224KXZE1	FDU280KXZE1
Nominal cooling capacity	kW	22.4	28.0
Nominal heating capacity	kW	25.0	31.5
Power source		1 Phase 220-240V, 50Hz	
Power consumption	Cooling	1.16-1.20	
	Heating	1.16-1.20	
Sound power level	dB(A)	75	
Sound pressure level	dB(A)	P-Hi:52 Hi:50 Me:47 Lo:45	
Exterior dimensions (H x W x D)	mm	379x1600x893	
Net weight	kg	89	
Air flow	m <sup>3</sup> /min	P-Hi:80 Hi:72 Me:64 Lo:56	
Maximum external static pressure	Pa	200	
Outside air intake		Possible(on return duct)	
Air filter, Q'ty		Procure locally	
Remote control (option)		wired:RC-EX3D, RC-E5, RCH-E3 wireless:RCN-KIT4-E2	
Installation data Refrigerant piping size	mm(in)	Liquid line:ø9.52(3/8") Gas line:ø19.05(3/4")	Liquid line:ø9.52(3/8") Gas line:ø22.22(7/8")

- The data are measured under the following conditions(ISO-T1). Cooling: Indoor temp. of 27°CDB, 19°CWB, and outdoor temp. of 35°CDB. Heating: Indoor temp. of 20°CDB, and outdoor temp. of 7°CDB, 6°CWB.
- Sound pressure level indicates the value in an anechoic chamber. During operation these values are somewhat higher due to ambient conditions.

# Dimensions

All measurements in mm.

FDU45KXE6F-W, 56KXE6F-W  
FDU45KXE6F, 56KXE6F

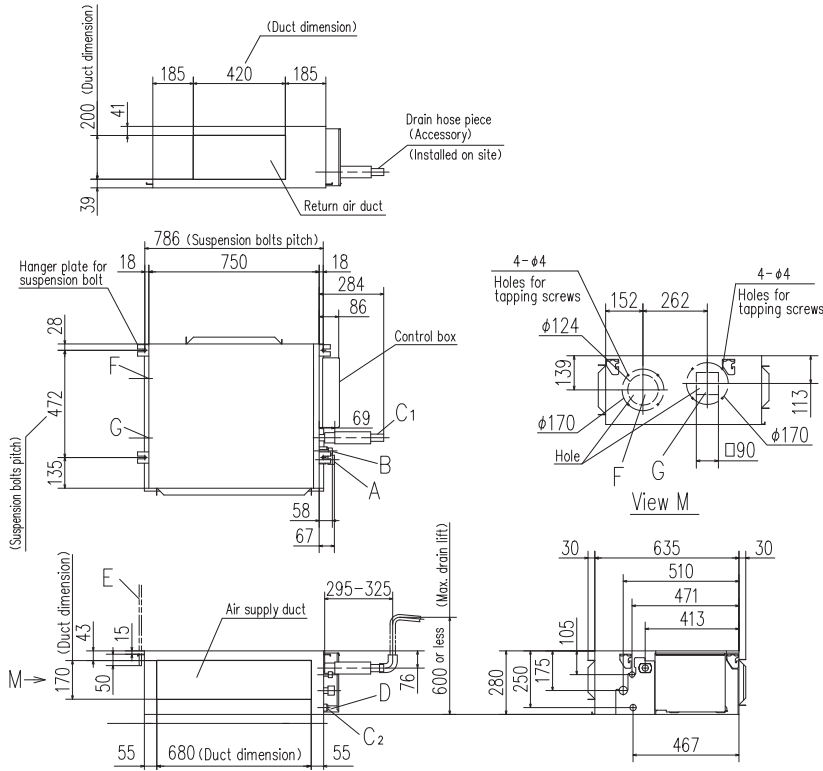

Symbol	Content	
A	Gas piping	φ12.7 (1/2") (Flare)
B	Liquid piping	φ6.35 (1/4") (Flare)
C1	Drain piping	VP25 (O.D.32)
C2	Drain piping (Gravity drainage)	VP20
D	Hole for wiring	
E	Suspension bolts	M10
F	Outside air opening for ducting	(Knock out)
G	Air outlet opening for ducting	(Knock out)
H	Inspection opening	(450X450)

### Space for installation and service

Select either of two cases to keep space for installation and services.  
(Case 1) From side of unit

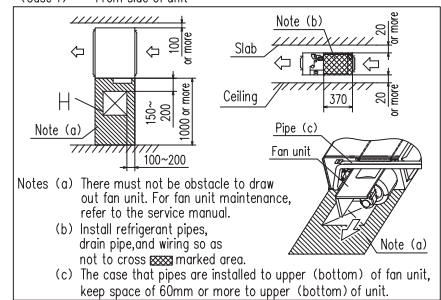

(Case 2) From bottom of unit

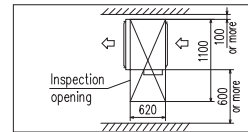

Note (1) The model name label is attached on the lid of the control box.

FDU71KXE6F-W, 90KXE6F-W  
FDU71KXE6F, 90KXE6F

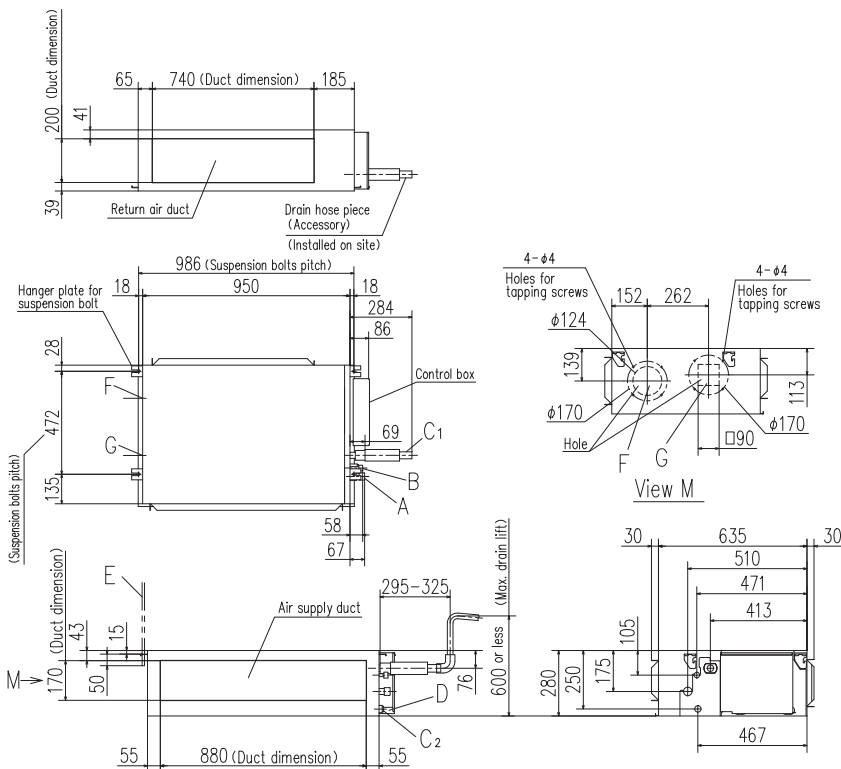

Symbol	Content	
A	Gas piping	φ15.88 (5/8") (Flare)
B	Liquid piping	φ9.52 (3/8") (Flare)
C1	Drain piping	VP25 (O.D.32)
C2	Drain piping (Gravity drainage)	VP20
D	Hole for wiring	
E	Suspension bolts	M10
F	Outside air opening for ducting	(Knock out)
G	Air outlet opening for ducting	(Knock out)
H	Inspection opening	(450X450)

### Space for installation and service

Select either of two cases to keep space for installation and services.  
(Case 1) From side of unit

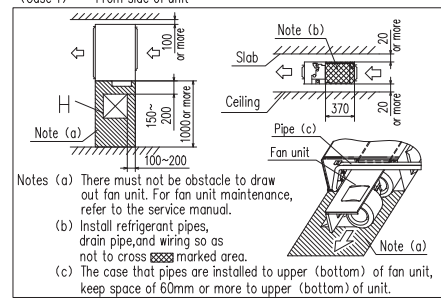

(Case 2) From bottom of unit

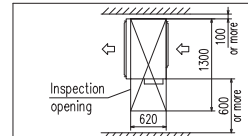

Note (1) The model name label is attached on the lid of the control box.

FDU112KXE6F-W, 140KXE6F-W, 160KXE6F-W  
FDU112KXE6F, 140KXE6F, 160KXE6F

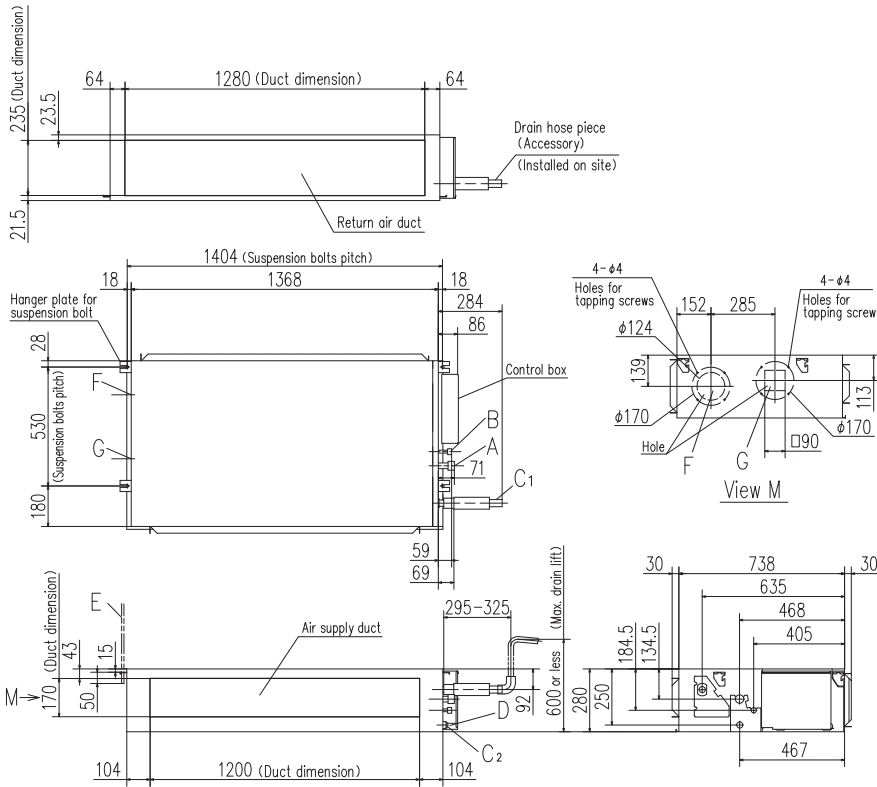

Symbol	Content
A	Gas piping $\phi 15.88$ (5/8") (Flare)
B	Liquid piping $\phi 9.52$ (3/8") (Flare)
C1	Drain piping VP25 (O.D.32)
C2	Drain piping (Gravity drainage) VP20
D	Hole for wiring
E	Suspension bolts M10
F	Outside air opening for ducting ( Knock out)
G	Air outlet opening for ducting ( Knock out)
H	Inspection opening (450X450)

Space for installation and service

Select either of two cases to keep space for installation and services.  
(Case 1) From side of unit

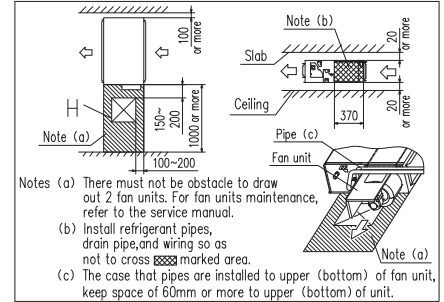

(Case 2) From bottom of unit

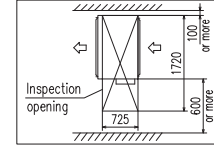

Note  
(1) The model name label is attached on the lid of the control box.

FDU224KXE1, 280KXE1

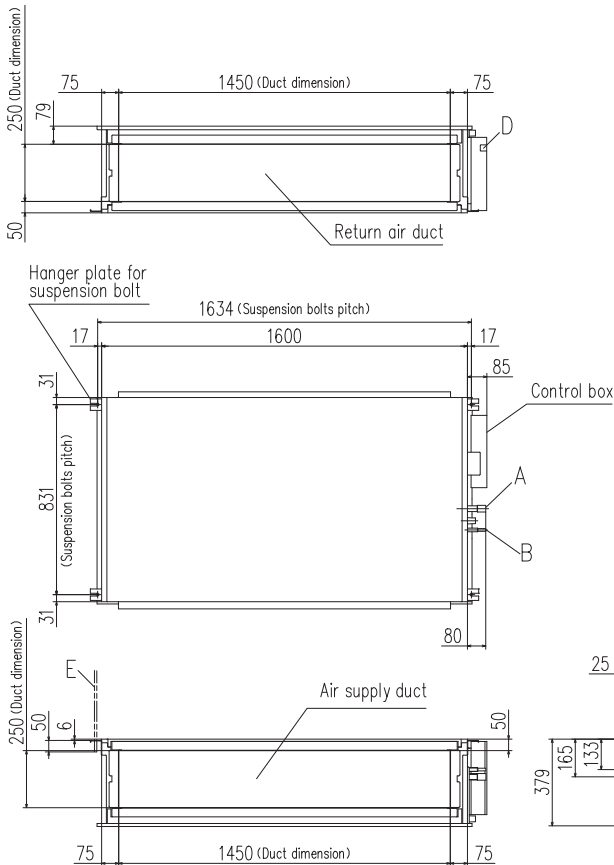

Symbol	Content		
	MODEL	224	280
A	Gas piping	$\phi 19.05$ (3/4") (Brazing)	$\phi 22.22$ (7/8") (Brazing)
B	Liquid piping	$\phi 9.52$ (3/8") (Brazing)	
C	Drain piping (Gravity drainage)	VP25 (O.D.32)	
D	Hole for wiring		
E	Suspension bolts	M10	
F	Inspection hole	(450X450)	

Space for installation and service

Select either of two cases to keep space for installation and services.  
(Case 1) From side of unit

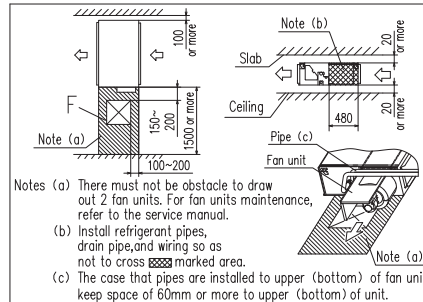

(Case 2) From bottom of unit

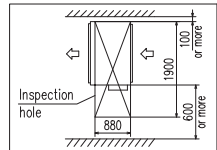

Notes (1) The model name label is attached on the lid of the control box.

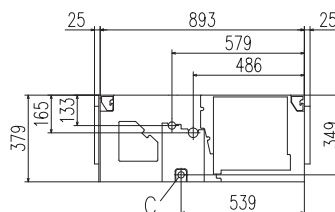



# Duct Connected -Low/Middle Static Pressure- FDUM

## Model No.

FDUM22KXE6F-W	FDUM22KXE6F
FDUM28KXE6F-W	FDUM28KXE6F
FDUM36KXE6F-W	FDUM36KXE6F
FDUM45KXE6F-W	FDUM45KXE6F
FDUM56KXE6F-W	FDUM56KXE6F
FDUM71KXE6F-W	FDUM71KXE6F
FDUM90KXE6F-W	FDUM90KXE6F
FDUM112KXE6F-W	FDUM112KXE6F
FDUM140KXE6F-W	FDUM140KXE6F
FDUM160KXE6F-W	FDUM160KXE6F



## Remote control (option)

Wired



RC-EX3D RC-E5 RCH-E3

Wireless



RCN-KIT4-E2

\*R32 indoor unit are not compatible with R410A outdoor unit and vice versa.

## Filter kit (option)

UM-FL1EF : for 22-56  
UM-FL2EF : for 71, 90  
UM-FL3EF : for 112, 140, 160



\*Filter pressure loss:5pa

## Automatic external static pressure (E.S.P.) control

Using the automatic control, DC motor, the most optimum air flow volume is achieved. The Indoor unit will recognise external static pressure automatically and keep rated air flow volume.

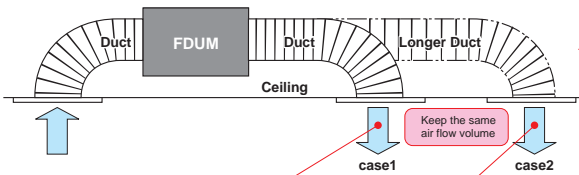

E.S.P. button RC-E5  
External static pressure (E.S.P.) can be set by E.S.P. button.

Setting No.	No.1	No.2	No.3	No.4	No.5	No.6	No.7	No.8	No.9	No.10
E.S.P.	10Pa	20Pa	30Pa	40Pa	50Pa	60Pa	70Pa	80Pa	90Pa	100Pa

## Thin design

The height of all FDUM models only 280mm



## Transparent inspection window

Dirt condition of the bottom of the drain pan can be checked through this transparent inspection window without removing drain pan. (Please refer to P88)

## Motion Sensor

(Option)

Motion sensor is equipped in the ceiling plane or wall plane and detects the presence/absence and activity of humans in a room to improve the comfort and energy saving performance of the unit.



LB-KIT2

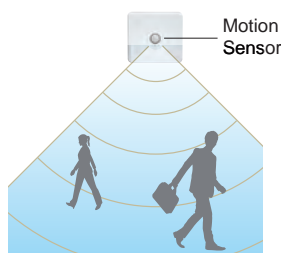

## Improvement of the serviceability

Fan unit (impeller and motor) can be pulled out from the right side or the bottom side of the unit. Maintenance can be carried out from the right side or the bottom side of the unit.

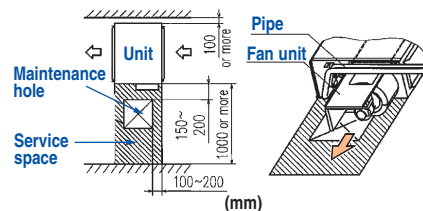

# Specifications



Item	Model	FDUM22KXE6F-W	FDUM28KXE6F-W	FDUM36KXE6F-W	FDUM45KXE6F-W	FDUM56KXE6F-W
Nominal cooling capacity	kW	2.2	2.8	3.6	4.5	5.6
Nominal heating capacity	kW	2.5	3.2	4.0	5.0	6.3
Power source		1 Phase 220-240V, 50Hz				
Power consumption	Cooling	0.08-0.08				
	Heating	0.08-0.08				
Sound power level	dB(A)	Cooling:57 Heating:60		Cooling:58 Heating:60		
Sound pressure level	Cooling	P-Hi:33 Hi:27 Me:25 Lo:23		P-Hi:34 Hi:29 Me:27 Lo:25		
	Heating	P-Hi:36 Hi:30 Me:29 Lo:25		P-Hi:35 Hi:30 Me:29 Lo:25		
Exterior dimensions (H x W x D)	mm	280 x 750 x 635				
Net weight	kg	29				
Air flow	m <sup>3</sup> /min	P-Hi:13 Hi:10 Me:9 Lo:8				
Maximum external static pressure	Pa	100				
Outside air intake		Possible				
Air filter, Q'ty		Filter kit:UM-FL1EF				
Remote control (option)		wired:RC-EX3D, RC-E5, RCH-E3 wireless:RCN-KIT4-E2				
Installation data Refrigerant piping size	mm(in)	Liquid line:ø6.35(1/4") Gas line:ø9.52(3/8")		Liquid line:ø6.35(1/4") Gas line:ø12.7(1/2")		

Item	Model	FDUM71KXE6F-W	FDUM90KXE6F-W	FDUM112KXE6F-W	FDUM140KXE6F-W	FDUM160KXE6F-W
Nominal cooling capacity	kW	7.1	9.0	11.2	14.0	16.0
Nominal heating capacity	kW	8.0	10.0	12.5	16.0	18.0
Power source		1 Phase 220-240V, 50Hz				
Power consumption	Cooling	0.16-0.16	0.25-0.25	0.25-0.25	0.26-0.26	0.38-0.38
	Heating	0.16-0.16	0.25-0.25	0.25-0.25	0.26-0.26	0.38-0.38
Sound power level	dB(A)	Cooling:63 Heating:65	Cooling:68 Heating:69			72
Sound pressure level	Cooling	P-Hi:37 Hi:31 Me:27 Lo:22	P-Hi:40 Hi:36 Me:34 Lo:28		P-Hi:41 Hi:37 Me:34 Lo:28	
	Heating	P-Hi:39 Hi:33 Me:28 Lo:23	P-Hi:41 Hi:36 Me:34 Lo:28		P-Hi:45 Hi:38 Me:34 Lo:29	
Exterior dimensions (H x W x D)	mm	280 x 950 x 635	280 x 1368 x 740			
Net weight	kg	34	54			
Air flow	m <sup>3</sup> /min	P-Hi:24 Hi:19 Me:15 Lo:10	P-Hi:36 Hi:28 Me:25 Lo:19	P-Hi:39 Hi:32 Me:26 Lo:20	P-Hi:48 Hi:35 Me:28 Lo:22	
Maximum external static pressure	Pa	100				
Outside air intake		Possible				
Air filter, Q'ty		Filter kit:UM-FL2EF		Filter kit:UM-FL3EF		
Remote control (option)		wired:RC-EX3D, RC-E5, RCH-E3 wireless:RCN-KIT4-E2				
Installation data Refrigerant piping size	mm(in)	Liquid line:ø9.52(3/8") Gas line:ø15.88(5/8")				

# Specifications



Item	Model	FDUM22KXE6F	FDUM28KXE6F	FDUM36KXE6F	FDUM45KXE6F	FDUM56KXE6F
Nominal cooling capacity	kW	2.2	2.8	3.6	4.5	5.6
Nominal heating capacity	kW	2.5	3.2	4.0	5.0	6.3
Power source		1 Phase 220-240V, 50Hz				
Power consumption	Cooling	0.10-0.10				
	Heating	0.10-0.10				
Sound power level	dB(A)	60				
Sound pressure level	dB(A)	P-Hi:37 Hi:32 Me:29 Lo:26				
Exterior dimensions (H x W x D)	mm	280 x 750 x 635				
Net weight	kg	29				
Air flow	m <sup>3</sup> /min	P-Hi:13 Hi:10 Me:9 Lo:8				
Maximum external static pressure	Pa	100				
Outside air intake		Possible				
Air filter, Q'ty		Filter kit:UM-FL1EF				
Remote control (option)		wired:RC-EX3D, RC-E5, RCH-E3 wireless:RCN-KIT4-E2				
Installation data Refrigerant piping size	mm(in)	Liquid line:ø6.35(1/4") Gas line:ø9.52(3/8")		Liquid line:ø6.35(1/4") Gas line:ø12.7(1/2")		

Item	Model	FDUM71KXE6F	FDUM90KXE6F	FDUM112KXE6F	FDUM140KXE6F	FDUM160KXE6F
Nominal cooling capacity	kW	7.1	9.0	11.2	14.0	16.0
Nominal heating capacity	kW	8.0	10.0	12.5	16.0	18.0
Power source		1 Phase 220-240V, 50Hz				
Power consumption	Cooling	0.20-0.20	0.29-0.29	0.29-0.29	0.33-0.33	0.45-0.45
	Heating	0.20-0.20	0.29-0.29	0.29-0.29	0.33-0.33	0.45-0.45
Sound power level	dB(A)	65		71	72	74
Sound pressure level	dB(A)	P-Hi:38 Hi:33 Me:29 Lo:25		P-Hi:44 Hi:38 Me:36 Lo:30	P-Hi:45 Hi:40 Me:34 Lo:29	P-Hi:47 Hi:40 Me:35 Lo:30
Exterior dimensions (H x W x D)	mm	280 x 950 x 635		280 x 1368 x 740		
Net weight	kg	34		54		
Air flow	m <sup>3</sup> /min	P-Hi:24 Hi:19 Me:15 Lo:10	P-Hi:36 Hi:28 Me:25 Lo:19	P-Hi:39 Hi:32 Me:26 Lo:20	P-Hi:48 Hi:35 Me:28 Lo:22	
Maximum external static pressure	Pa	100				
Outside air intake		Possible				
Air filter, Q'ty		Filter kit:UM-FL2EF		Filter kit:UM-FL3EF		
Remote control (option)		wired:RC-EX3D, RC-E5, RCH-E3 wireless:RCN-KIT4-E2				
Installation data Refrigerant piping size	mm(in)	Liquid line:ø9.52(3/8") Gas line:ø15.88(5/8")				

1. The data are measured under the following conditions(ISO-T1). Cooling: Indoor temp. of 27°CDB, 19°CWB, and outdoor temp. of 35°CDB. Heating: Indoor temp. of 20°CDB, and outdoor temp. of 7°CDB, 6°CWB.  
 2. Sound pressure level indicates the value in an anechoic chamber. During operation these values are somewhat higher due to ambient conditions.

# Dimensions

All measurements in mm.

FDUM22KXE6F-W, 28KXE6F-W, 36KXE6F-W, 45KXE6F-W, 56KXE6F-W  
 FDUM22KXE6F, 28KXE6F, 36KXE6F, 45KXE6F, 56KXE6F

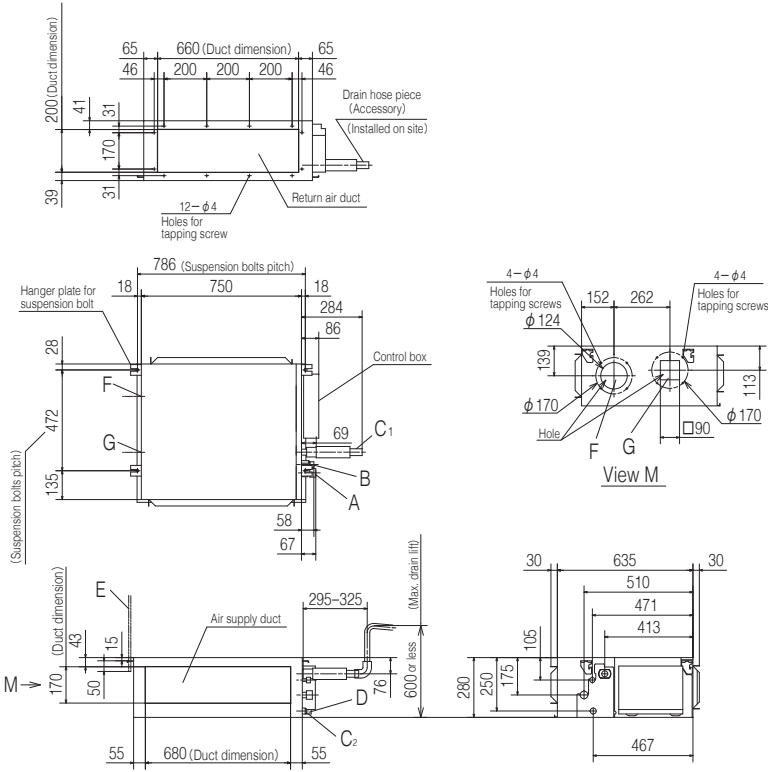

### Space for installation and service

Select either of two cases to keep space for installation and services.

(Case 1) From side of unit

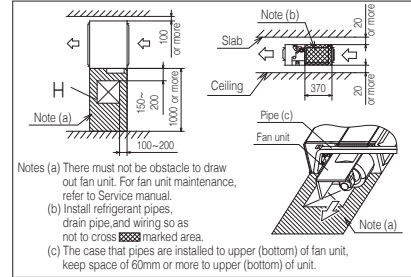

Notes (a) There must not be obstacle to draw out fan unit. For fan unit maintenance, refer to Service manual.  
 (b) Install refrigerant pipes, drain pipe, and wiring so as not to cross marked area.  
 (c) The case that pipes are installed to upper (bottom) of fan unit, keep space of 60mm or more to upper (bottom) of unit.

(Case 2) From bottom of unit

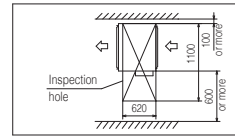

Symbol	Model	Content
	2228	36.45.56
A	Gas piping	φ9.52(3/8") (Flare) φ12.7(1/2") (Flare)
B	Liquid piping	φ6.35(1/4") (Flare)
C1	Drain piping	VP25 (O.D.32)
C2	Drain piping (Gravity drainage)	VP20 (O.D.26)
D	Hole for wiring	
E	Suspension bolts	(M10)
F	Outside air opening for ducting	(φ150) (Knock out)
G	Air outlet opening for ducting	(φ125) (Knock out)
H	Inspection hole	(450X450)

Note The model name label is attached on the lid of the control box.

FDUM71KXE6F-W, 90KXE6F-W  
 FDUM71KXE6F, 90KXE6F

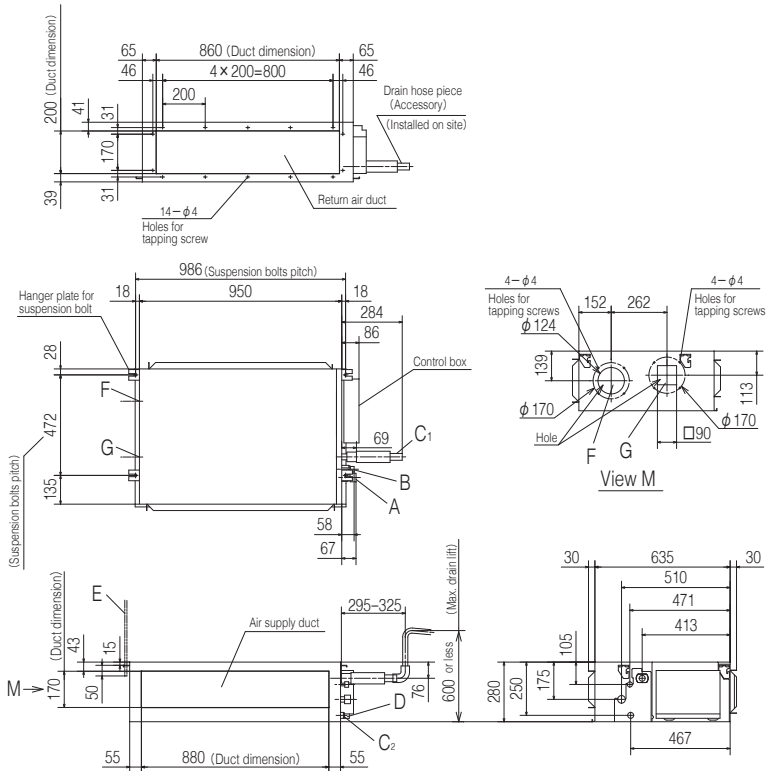

### Space for installation and service

Select either of two cases to keep space for installation and services.

(Case 1) From side of unit

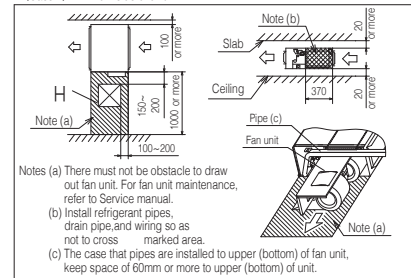

Notes (a) There must not be obstacle to draw out fan unit. For fan unit maintenance, refer to Service manual.  
 (b) Install refrigerant pipes, drain pipe, and wiring so as not to cross marked area.  
 (c) The case that pipes are installed to upper (bottom) of fan unit, keep space of 60mm or more to upper (bottom) of unit.

(Case 2) From bottom of unit

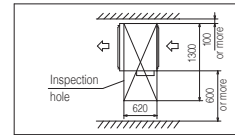

Symbol	Model	Content
	2228	36.45.56
A	Gas piping	φ15.88(5/8") (Flare)
B	Liquid piping	φ9.52(3/8") (Flare)
C1	Drain piping	VP25 (O.D.32)
C2	Drain piping (Gravity drainage)	VP20 (O.D.26)
D	Hole for wiring	
E	Suspension bolts	(M10)
F	Outside air opening for ducting	(φ150) (Knock out)
G	Air outlet opening for ducting	(φ125) (Knock out)
H	Inspection hole	(450X450)

Note The model name label is attached on the lid of the control box.

FDUM112KXE6F-W, 140KXE6F-W, 160KXE6F-W  
 FDUM112KXE6F, 140KXE6F, 160KXE6F

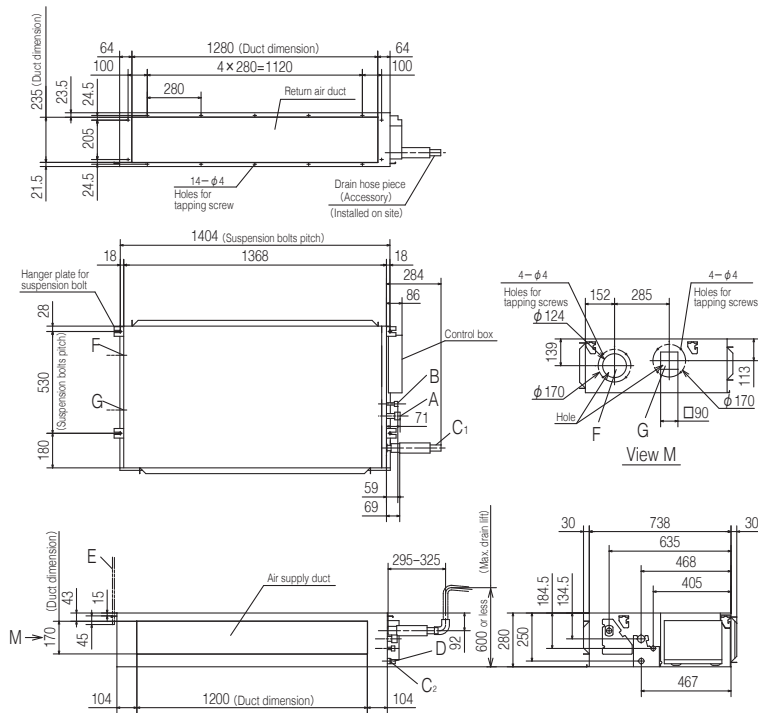

Space for installation and service

Select either of two cases to keep space for installation and services.

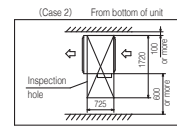
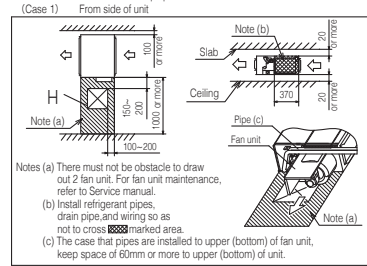

Symbol	Content
A	Gas piping (ø 15.88 (5/8") (Flare))
B	Liquid piping (ø 9.52 (3/8") (Flare))
C1	Drain piping (VP25 (O.D.32))
C2	Drain piping (Gravity drainage) (VP20 (O.D.26))
D	Hole for wiring
E	Suspension bolts (M10)
F	Outside air opening for ducting (ø 150) ( Knock out)
G	Air outlet opening for ducting (ø 125) ( Knock out)
H	Inspection hole (450X450)

Notes (1) The model name label is attached on the lid of the control box.

# Duct Connected (thin) -Low Static Pressure- FDUT

## Model No.

FDUT15KXE6F-W	FDUT15KXE6F-E
FDUT22KXE6F-W	FDUT22KXE6F-E
FDUT28KXE6F-W	FDUT28KXE6F-E
FDUT36KXE6F-W	FDUT36KXE6F-E
FDUT45KXE6F-W	FDUT45KXE6F-E
FDUT56KXE6F-W	FDUT56KXE6F-E
FDUT71KXE6F-W	FDUT71KXE6F-E

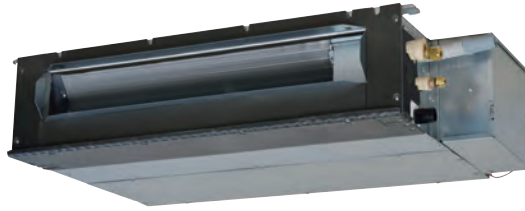

## Remote control (option)

Wired



Wireless



RCN-KIT4-E2

\*R32 indoor unit are not compatible with R410A outdoor unit and vice versa.

## Motion Sensor

(Option)

Motion sensor is equipped in the ceiling plane or wall plane and detects the presence/absence and activity of humans in a room to improve the comfort and energy saving performance of the unit.



LB-KIT2

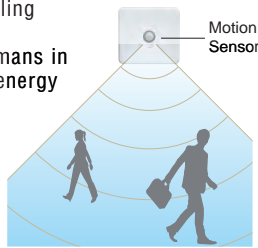

## Filter kit

(Option)

Item	Contents	for FDUT15/22/28/36	for FDUT45/56	for FDUT71
Outlet duct plate	①	UT-SAT1EF	UT-SAT2EF	UT-SAT3EF
Filter set	②+③	UT-FL1EF	UT-FL2EF	UT-FL3EF

Filter pressure loss : 5 Pa

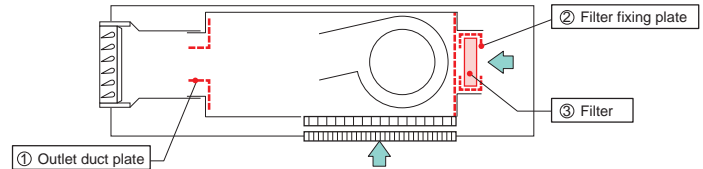

## Specifications



Item	Model	FDUT15KXE6F-W	FDUT22KXE6F-W	FDUT28KXE6F-W	FDUT36KXE6F-W	FDUT45KXE6F-W	FDUT56KXE6F-W	FDUT71KXE6F-W
Nominal cooling capacity	kW	1.5	2.2	2.8	3.6	4.5	5.6	7.1
Nominal heating capacity	kW	1.7	2.5	3.2	4.0	5.0	6.0	8.0
Power source		1 Phase 220-240V, 50Hz						
Power consumption	Cooling	0.057-0.058	0.063-0.066	0.067-0.070	0.075-0.078	0.076-0.080	0.08-0.08	
	Heating	0.057-0.058	0.065-0.067	0.070-0.072	0.072-0.076	0.073-0.078	0.07-0.07	
Sound power level	dB(A)	Cooling:52 Heating:51	52	Cooling:54 Heating:55	54	55	Cooling:56 Heating:57	
Sound pressure level *1	Cooling	Hi:28 Me:26 Lo:21	Hi:28 Me:26 Lo:22	Hi:30 Me:28 Lo:24	Hi:30 Me:26 Lo:24	Hi:31 Me:27 Lo:24	Hi:32 Me:28 Lo:27	
	Heating	Hi:28 Me:25 Lo:20		Hi:31 Me:29 Lo:25	Hi:30 Me:27 Lo:25	Hi:31 Me:28 Lo:26	Hi:32 Me:28 Lo:26	
Sound pressure level *2	Cooling	Hi:32 Me:29 Lo:25	Hi:32 Me:29 Lo:25	Hi:37 Me:34 Lo:28	Hi:36 Me:33 Lo:27	Hi:38 Me:33 Lo:29	Hi:41 Me:37 Lo:32	
	Heating							
Exterior dimensions (H x W x D)	mm	200x750x500				200x950x500		220x1150x565
Net weight	kg	22	21	22	25	31		
Air flow (Standard)	m <sup>3</sup> /min	Hi:6 Me:5 Lo:4	Hi:7.5 Me:6 Lo:5	Hi:8.5 Me:7 Lo:5.5	Hi:11.5 Me:9 Lo:7	Hi:12.5 Me:9 Lo:7.2	Hi:16 Me:13 Lo:9.5	
External Static pressure	Pa	Standard: 10 Max: 35				Standard: 10 Max: 50		
Outside air intake		Possible from return duct						
Air filter (option)		Filter set:UT-FL1EF				Filter set:UT-FL2EF		Filter set:UT-FL3EF
Remote control (option)		wired:RC-EX3D, RC-E5, RCH-E3 wireless:RCN-KIT4-E2						
Installation data Refrigerant piping size	mm(in)	Liquid line:ø6.35(1/4") Gas line:ø9.52(3/8")			Liquid line:ø6.35(1/4") Gas line:ø12.7(1/2")			Liquid line:ø9.52(3/8") Gas line:ø15.88(5/8")

## Specifications



Item	Model	FDUT15KXE6F-E	FDUT22KXE6F-E	FDUT28KXE6F-E	FDUT36KXE6F-E	FDUT45KXE6F-E	FDUT56KXE6F-E	FDUT71KXE6F-E
Nominal cooling capacity	kW	1.5	2.2	2.8	3.6	4.5	5.6	7.1
Nominal heating capacity	kW	1.7	2.5	3.2	4.0	5.0	6.0	8.0
Power source		1 Phase 220-240V, 50Hz						
Power consumption	Cooling	0.06-0.06	0.07-0.07	0.08-0.08	0.08-0.08	0.08-0.08	0.08-0.08	
	Heating	0.06-0.06	0.07-0.07	0.08-0.08	0.08-0.08	0.08-0.08	0.07-0.07	
Sound power level	dB(A)	52	57	58	59			
Sound pressure level *1	dB(A)	Hi:28 Me:26 Lo:22	Hi:33 Me:30 Lo:26	Hi:34 Me:32 Lo:28	Hi:35 Me:33 Lo:30	Hi:35 Me:31 Lo:28		
Sound pressure level *2	dB(A)	Hi:32 Me:29 Lo:25	Hi:37 Me:34 Lo:28	Hi:36 Me:33 Lo:27	Hi:38 Me:33 Lo:29	Hi:41 Me:37 Lo:32		
Exterior dimensions (H x W x D)	mm	200x750x500				200x950x500		220x1150x565
Net weight	kg	22	21	22	25	31		
Air flow (Standard)	m <sup>3</sup> /min	Hi:6 Me:5 Lo:4	Hi:7.5 Me:6 Lo:5	Hi:8.5 Me:7 Lo:5.5	Hi:11.5 Me:9 Lo:7	Hi:12.5 Me:9 Lo:7.2	Hi:16 Me:13 Lo:9.5	
External Static pressure	Pa	Standard: 10 Max: 35				Standard: 10 Max: 50		
Outside air intake		Possible from return duct						
Air filter (option)		Filter set:UT-FL1EF				Filter set:UT-FL2EF		Filter set:UT-FL3EF
Remote control (option)		wired:RC-EX3D, RC-E5, RCH-E3 wireless:RCN-KIT4-E2						
Installation data Refrigerant piping size	mm(in)	Liquid line:ø6.35(1/4") Gas line:ø9.52(3/8")			Liquid line:ø6.35(1/4") Gas line:ø12.7(1/2")			Liquid line:ø9.52(3/8") Gas line:ø15.88(5/8")

1. The data are measured under the following conditions(ISO-T1). Cooling: Indoor temp. of 27°CDB, 19°CWB, and outdoor temp. of 35°CDB. Heating: Indoor temp. of 20°CDB, and outdoor temp. of 7°CDB, 6°CWB.

2. The data of nominal cooling and heating capacity and sound pressure level are measured with 10Pa of external static pressure.

3. The sound level indicates the value of rear-inlet type with duct in anechoic chamber. During operation these values are somewhat higher due to ambient conditions.

4. Sound Pressure Level shows the value when the supply duct of 2m and the return duct of 1m (except the Bottom air return) are connected to the unit.

Sound pressure level \*1 : Mike position is 1.5m below the unit, \*2 : Mike position is 1m in front and 1m below of the air supply duct.

# Dimensions

All measurements in mm.

FDUT15KXE6F-W, 22KXE6F-W, 28KXE6F-W, 36KXE6F-W  
 FDUT15KXE6F-E, 22KXE6F-E, 28KXE6F-E, 36KXE6F-E

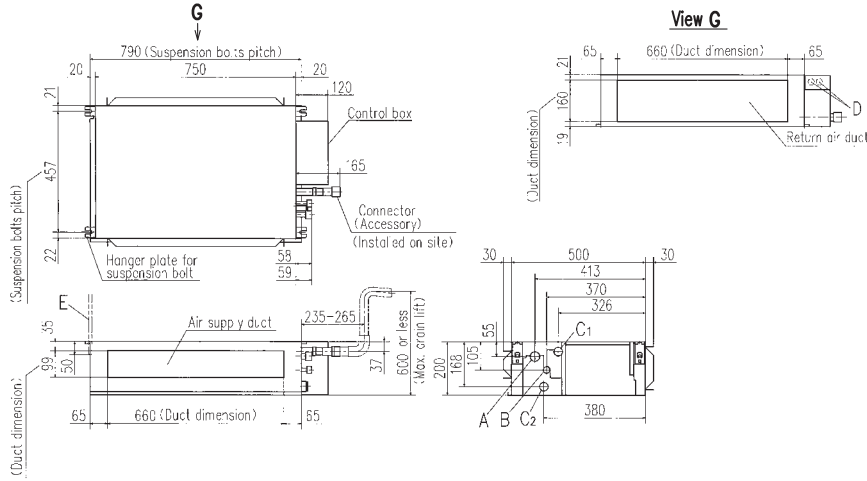

Symbol	Material	Content
	Material	45, 36
A	Gas piping	φ1.5 (1/8") (Flare)
B	Liquid piping	φ1.5 (1/8") (Flare)
C1	Drain piping	VP25 (D. 25, 0.0. 32)
C2	Drain piping (Gravity drainage)	VP25 (D. 25, 0.0. 32)
D	Note for wiring	φ25 x 2
E	Suspension bolts	(M16)
F	Inspection hole	(φ50x400, 120x170)

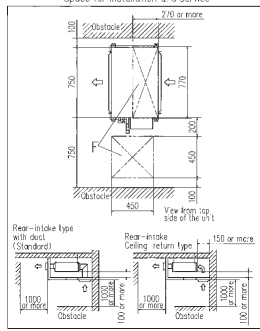

FDUT45KXE6F-W, 56KXE6F-W  
 FDUT45KXE6F-E, 56KXE6F-E

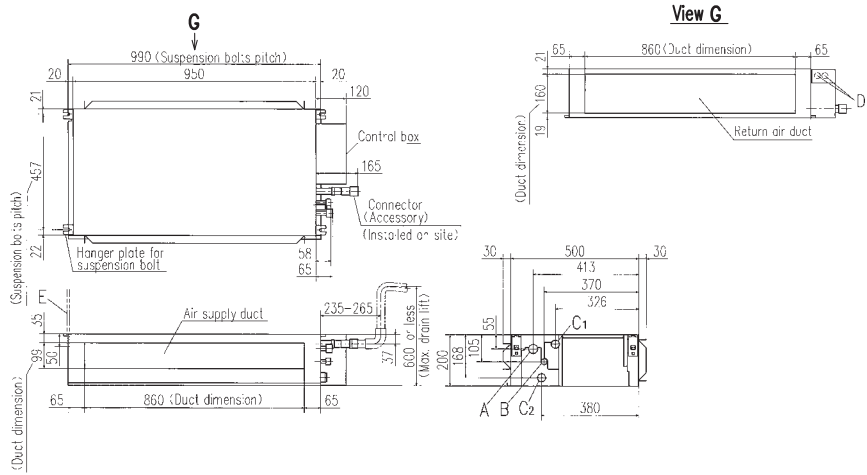

Symbol	Material	Content
	Material	45, 36
A	Gas piping	φ1.2 (1/2") (Flare)
B	Liquid piping	φ1.2 (1/2") (Flare)
C1	Drain piping	VP25 (D. 25, 0.0. 32)
C2	Drain piping (Gravity drainage)	VP25 (D. 25, 0.0. 32)
D	Note for wiring	φ25 x 2
F	Suspension bolts	(M20)
F	Inspection hole	(φ50x450, 120x170)

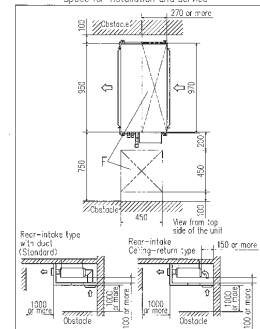

FDUT71KXE6F-W  
 FDUT71KXE6F-E

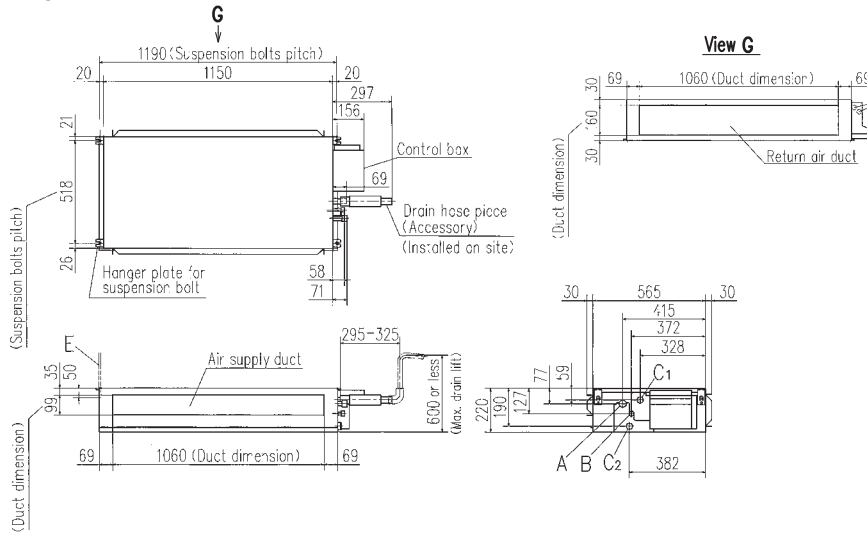

Symbol	Material	Content
	Material	71
A	Gas piping	φ1.5 (1/8") (Flare)
B	Liquid piping	φ1.5 (1/8") (Flare)
C1	Drain piping	(Used with attached socket)
C2	Drain piping (Gravity drainage)	VP25 (D. 25, 0.0. 32)
D	Note for wiring	(Used with attached socket)
E	Note for wiring	φ25 x 2
F	Suspension bolts	(M16)
F	Inspection hole	(φ50x450, 120x170)

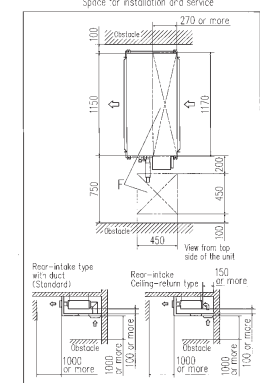

# Duct Connected (Compact & Flexible) FDUH

**Model No.**  
FDUH22KXE6F  
FDUH28KXE6F  
FDUH36KXE6F

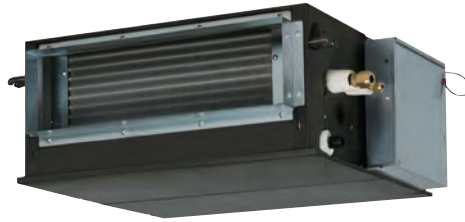

## Remote control (option)

Wired



RC-EX3D RC-E5 RCH-E3

Wireless



RCN-KIT4-E2

## Filter kit (option) UH-FL1E



\* Filter pressure loss: 5pa

## Drain up kit (option) (600mm) UH-DU-E

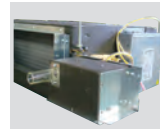

### Compact and thin size, light weight

Our leading high technology has created the best solution for air conditioning in hotels. The compact and thin sized units don't compromise on high energy efficiency all while weighing in at only 20kg.

The lowest sound level in the industry can ensure comfortable stay and rest in hotels.

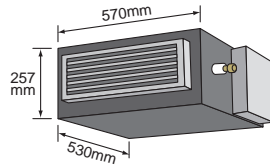

### Motion Sensor (Option)

Motion sensor is equipped in the ceiling plane or wall plane and detects the presence/absence and activity of humans in a room to improve the comfort and energy saving performance of the unit.



LB-KIT2

### Installation Flexibility

Control box and drain piping can be installed on both side of the unit and air intake to the unit is available from bottom or back side. Our highest technology can satisfy diverse installation requirements.

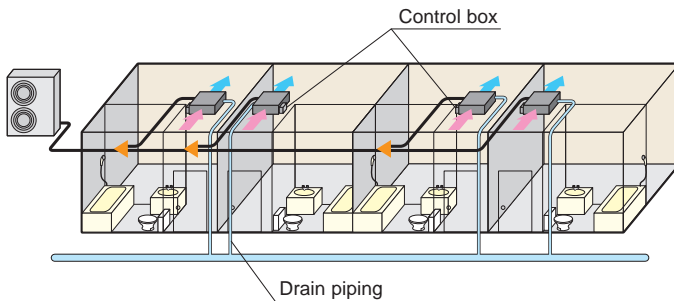

## Wired remote control



RCH-E3 (option)

### Simple remote control

Designed specially for hotel rooms, control buttons are limited only to the minimum required functions such as ON/OFF, mode, temperature setting and fan speed. It is really simple and easy to use.

## Specifications

Item	Model	FDUH22KXE6F	FDUH28KXE6F	FDUH36KXE6F
Nominal cooling capacity	kW	2.2	2.8	3.6
Nominal heating capacity	kW	2.5	3.2	4.0
Power source		1 Phase 220-240V, 50Hz		
Power consumption	Cooling	0.05-0.07		
	Heating	0.05-0.07		
Sound power level	dB(A)	60		
Sound pressure level	dB(A)	P-Hi:39 Hi: 33 Me: 30 Lo: 27		
Exterior dimensions HxWxD	mm	257x570x530		
Net weight	kg	20		
Air flow	m <sup>3</sup> /min	P-Hi:8.5 Hi: 7 Me: 6.5 Lo: 6		
External static pressure	Pa	30		
Outside air intake		Not possible		
Air filter		Filter kit:UH-FL1E(option)		
Remote control(option)		wired:RC-EX3D, RC-E5, RCH-E3 wireless:RCN-KIT4-E2		
Installation data	mm(in)	Liquid line:ø6.35(1/4")		Liquid line:ø6.35(1/4")
	Refrigerant piping size	Gas line:ø9.52(3/8")		Gas line:ø12.7(1/2")

1. The data are measured under the following conditions (ISO-T1). Cooling: Indoor temp. of 27°CDB, 19°CWB, and outdoor temp. of 35°CDB. Heating: Indoor temp. of 20°CDB, and outdoor temp. of 7°CDB, 6°CWB.  
2. Sound pressure level indicates the value in an anechoic chamber. During operation these values are somewhat higher due to ambient conditions.

# Dimensions

All measurements in mm.

## Rear air return type

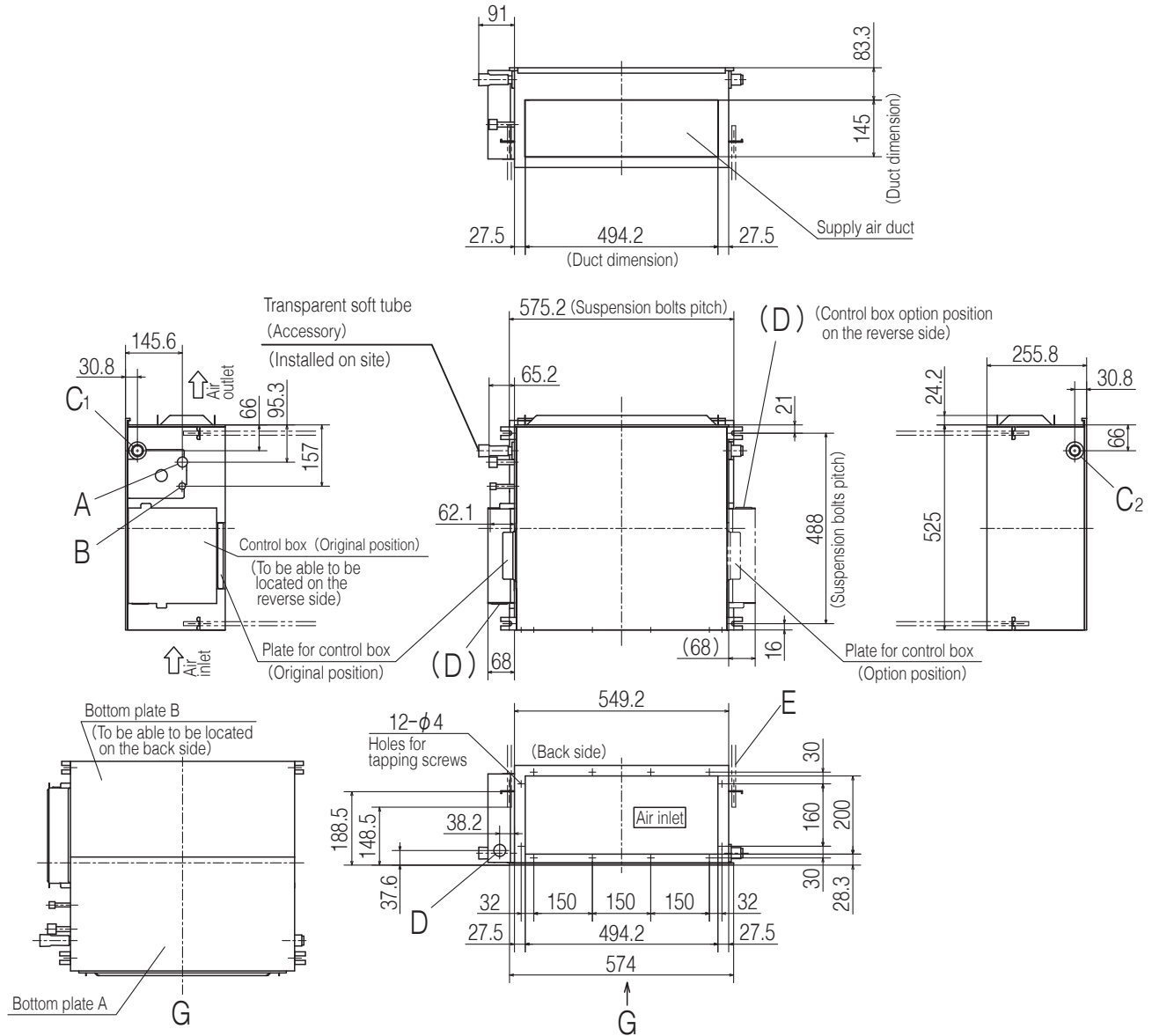

Symbol	Content		
	Model	22,28	36
A	Gas piping	φ9.52 (3/8") (Flare)	φ12.7 (1/2") (Flare)
B	Liquid piping	φ6.35 (1/4") (Flare)	
C <sub>1</sub>	Drain piping	VP20 (I.D.20,O.D.26) Note (2)	
C <sub>2</sub>	Drain piping	To be used instead of "C <sub>1</sub> "	
D	Hole for wiring	φ30	
E	Suspension bolts	(M10)	
F	Inspection hole	(590 x 1150) Note (3)	

### Notes

- (1) The model name label is attached on the fan couse inside the air return grille.
- (2) Prepare the connecting socket (VP20) on site.  
(As for drain piping, it is possible to choose C<sub>1</sub> or C<sub>2</sub>)
- (3) When control box is located on the reverse side, Installation space should be modified new location.

### Space for installation and service

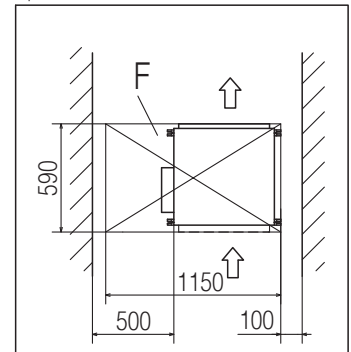

# Dimensions

All measurements in mm.

## Bottom suction type

Symbol	Content		
	Model	22,28	36
A	Gas piping	$\phi 9.52 (3/8")$ (Flare)	$\phi 12.7 (1/2")$ (Flare)
B	Liquid piping	$\phi 6.35 (1/4")$ (Flare)	
C <sub>1</sub>	Drain piping	VP20 (I.D.20,O.D.26) Note (2)	
C <sub>2</sub>	Drain piping	To be used instead of "C <sub>1</sub> "	
D	Hole for wiring	$\phi 30$	
E	Suspension bolts	(M10)	
F	Inspection hole	(555 x 1150) Note (3)	

### Notes

- (1) The model name label is attached on the fan case inside the air return grille.
- (2) Prepare the connecting socket (VP20) on site.  
(As for drain piping, it is possible to choose C<sub>1</sub> or C<sub>2</sub>.)
- (3) When control box is located on the reverse side, Installation space should be modified new location.

Space for installation and service

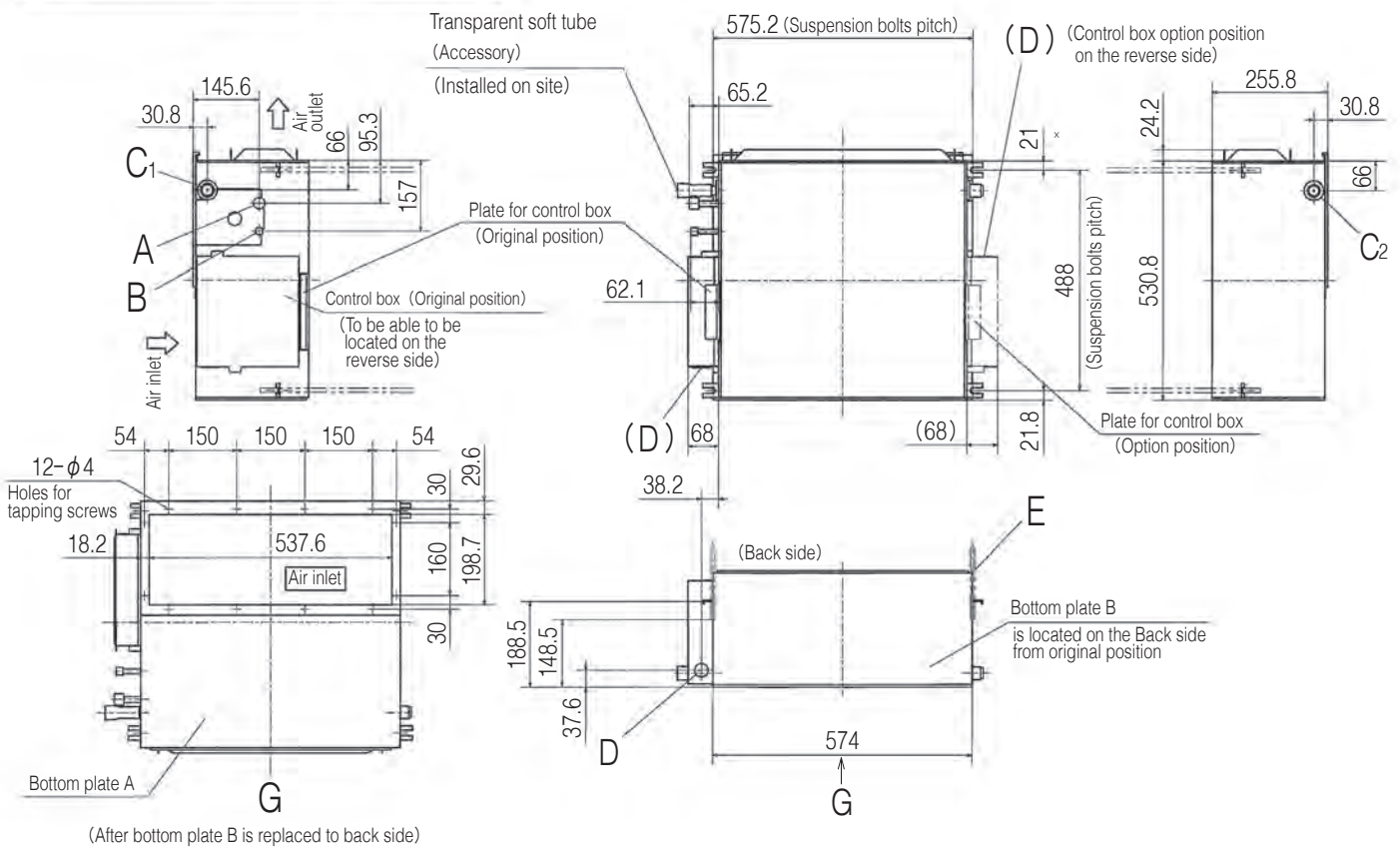
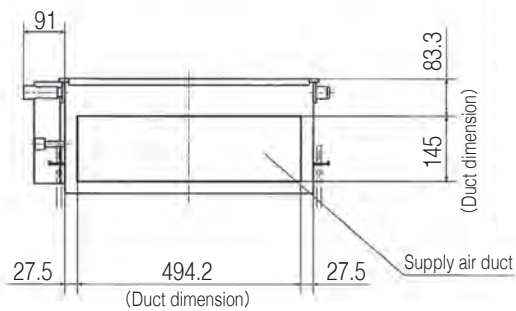
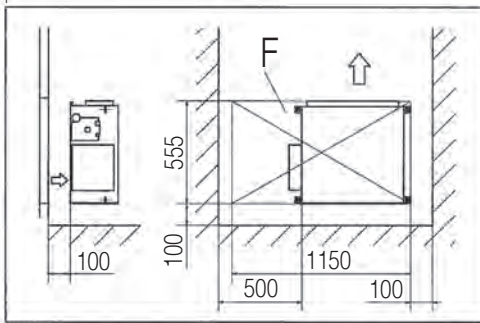

# Wall Mounted FDK

## Model No.

FDK15KXZE1-W	FDK15KXZE1
FDK22KXZE1-W	FDK22KXZE1
FDK28KXZE1-W	FDK28KXZE1
FDK36KXZE1-W	FDK36KXZE1
FDK45KXZE1-W	FDK45KXZE1
FDK56KXZE1-W	FDK56KXZE1
FDK71KXZE1-W	FDK71KXZE1
FDK90KXZE1-W	FDK90KXZE1



## Remote control (option)

### Wired

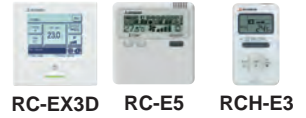

### Wireless



\*R32 indoor unit are not compatible with R410A outdoor unit and vice versa.

## Elegant Timeless Design

The FDK series air conditioners are innovatively designed with rounded contours that beautifully fit into any of Europe's diverse interior settings. Created by an Italian industrial design studio based in Milan, Tensa srl, the design meets a broad range of requirements. (FDK15-56)

## Jet Technology

FDK models adopt the air flow design that's proven to minimise resistance in a CFD analysis to achieve uniform air conditioning to the furthest corners of the room.

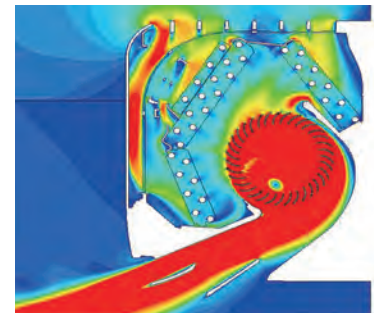

## Flap control system

Selection of flap position is possible. A flap can be set at different angles.

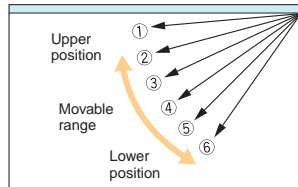

\*The wireless remote control is not applicable to the flap control system.

**Lateral Swing** ▶ flap swings from right to left automatically

**Up/Down Flap swing + Lateral swing**

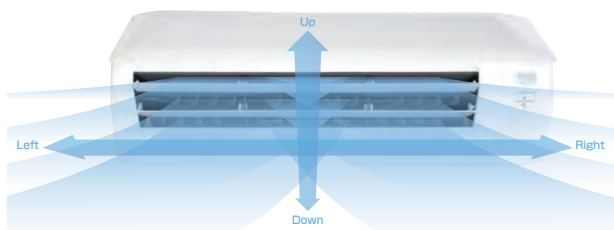

## Motion Sensor (Option)

Motion sensor is equipped in the ceiling plane or wall plane and detects the presence/absence and activity of humans in a room to improve the comfort and energy saving performance of the unit.

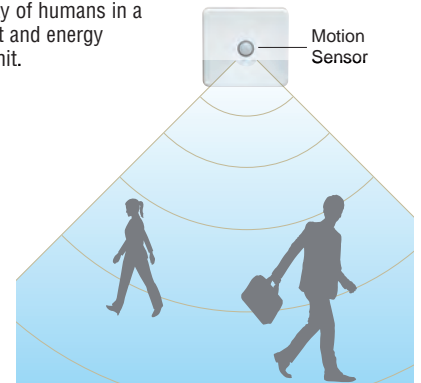

# Specifications

Item	Model	FDK15KXZE1-W	FDK22KXZE1-W	FDK28KXZE1-W	FDK36KXZE1-W	FDK45KXZE1-W	FDK56KXZE1-W	FDK71KXZE1-W	FDK90KXZE1-W	
Nominal cooling capacity	kW	1.5	2.2	2.8	3.6	4.5	5.6	7.1	9.0	
Nominal heating capacity	kW	1.7	2.5	3.2	4.0	5.0	6.3	8.0	10.0	
Power source		1 Phase 220-240V, 50Hz								
Power consumption	Cooling	0.02-0.02			0.03-0.03			0.04-0.04	0.05-0.05	
	Heating	0.02-0.02			0.03-0.03			0.04-0.04	0.05-0.05	
Sound power level	dB(A)	54	55	58			Cooling:58 Heating:61	59	61	
Sound pressure level	Cooling	P-Hi:38 Hi:34 Me:31 Lo:28	P-Hi:38 Hi:36 Me:30 Lo:27		P-Hi:40 Hi:38 Me:33 Lo:28	P-Hi:43 Hi:41 Me:36 Lo:33	P-Hi:43 Hi:41 Me:36 Lo:33	P-Hi:42 Hi:40 Me:37 Lo:35	P-Hi:44 Hi:42 Me:39 Lo:35	
	Heating					P-Hi:44 Hi:42 Me:37 Lo:33				
Exterior dimensions H x W x D	mm	290 x 870 x 230						339 x 1197 x 262		
Net weight	kg	11.5	11	11.5			17			
Air flow	Cooling	P-Hi:5.7 Hi:5 Me:4.5 Lo:3.6	P-Hi:8.5 Hi:8 Me:6 Lo:5		P-Hi:11 Hi:10 Me:8 Lo:7	P-Hi:12 Hi:11 Me:9 Lo:8	P-Hi:12 Hi:11 Me:9 Lo:8	P-Hi:21 Hi:19 Me:16 Lo:14	P-Hi:23 Hi:21 Me:19 Lo:16	
	Heating					P-Hi:13 Hi:12 Me:10 Lo:8				
Outside air intake		Not possible								
Air filter, Q'ty		Polypropylene net x2 (Washable)								
Remote control(option)		wired:RC-EX3D, RC-E5, RCH-E3 wireless:RCN-K-E2						wired:RC-EX3D, RC-E5, RCH-E3 wireless:RCN-K71-E2		
Installation data Refrigerant piping size	mm(in)	Liquid line:ø6.35(1/4") Gas line:ø9.52(3/8")			Liquid line:ø6.35(1/4") Gas line:ø12.7(1/2")			Liquid line:ø9.52(3/8") Gas line:ø15.88(5/8")		

1. The data are measured under the following conditions(ISO-T1). Cooling: Indoor temp. of 27°CDB, 19°CWB, and outdoor temp. of 35°CDB. Heating: Indoor temp. of 20°CDB, and outdoor temp. of 7°CDB, 6°CWB.  
2. Sound pressure level indicates the value in an anechoic chamber. During operation these values are somewhat higher due to ambient conditions.

# Specifications

Item	Model	FDK15KXZE1	FDK22KXZE1	FDK28KXZE1	FDK36KXZE1	FDK45KXZE1	FDK56KXZE1	FDK71KXZE1	FDK90KXZE1	
Nominal cooling capacity	kW	1.5	2.2	2.8	3.6	4.5	5.6	7.1	9.0	
Nominal heating capacity	kW	1.7	2.5	3.2	4.0	5.0	6.3	8.0	10.0	
Power source		1 Phase 220-240V, 50Hz								
Power consumption	Cooling	0.02-0.02			0.03-0.03			0.04-0.04	0.05-0.05	
	Heating	0.02-0.02			0.03-0.03			0.04-0.04	0.05-0.05	
Sound power level	dB(A)	54	55	58			Cooling:58 Heating:61	59	61	
Sound pressure level	Cooling	P-Hi:38 Hi:34 Me:31 Lo:28	P-Hi:38 Hi:36 Me:32 Lo:28		P-Hi:40 Hi:38 Me:33 Lo:28	P-Hi:43 Hi:41 Me:36 Lo:33	P-Hi:43 Hi:41 Me:36 Lo:33	P-Hi:42 Hi:40 Me:37 Lo:35	P-Hi:44 Hi:42 Me:39 Lo:35	
	Heating					P-Hi:44 Hi:42 Me:37 Lo:33				
Exterior dimensions H x W x D	mm	290 x 870 x 230						339 x 1197 x 262		
Net weight	kg	11.5	11	11.5			17			
Air flow	Cooling	P-Hi:5.7 Hi:5 Me:4.5 Lo:3.6	P-Hi:8.5 Hi:8 Me:6 Lo:5		P-Hi:11 Hi:10 Me:8 Lo:7	P-Hi:12 Hi:11 Me:9 Lo:8	P-Hi:12 Hi:11 Me:9 Lo:8	P-Hi:21 Hi:19 Me:16 Lo:14	P-Hi:23 Hi:21 Me:19 Lo:16	
	Heating					P-Hi:13 Hi:12 Me:10 Lo:8				
Outside air intake		Not possible								
Air filter, Q'ty		Polypropylene net x2 (Washable)								
Remote control(option)		wired:RC-EX3D, RC-E5, RCH-E3 wireless:RCN-K-E2						wired:RC-EX3D, RC-E5, RCH-E3 wireless:RCN-K71-E2		
Installation data Refrigerant piping size	mm(in)	Liquid line:ø6.35(1/4") Gas line:ø9.52(3/8")			Liquid line:ø6.35(1/4") Gas line:ø12.7(1/2")			Liquid line:ø9.52(3/8") Gas line:ø15.88(5/8")		

1. The data are measured under the following conditions(ISO-T1). Cooling: Indoor temp. of 27°CDB, 19°CWB, and outdoor temp. of 35°CDB. Heating: Indoor temp. of 20°CDB, and outdoor temp. of 7°CDB, 6°CWB.  
2. Sound pressure level indicates the value in an anechoic chamber. During operation these values are somewhat higher due to ambient conditions.

## External Expansion Valve Kit AP-EEV

External Expansion Valve Kit

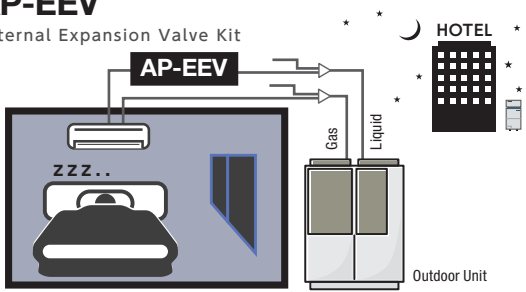

The option is available for the following capacity.  
※The option is compatible with the other indoor unit besides the FDK series.

## Ideal for air conditioning applications requiring high quietness.

Reduces noise levels near idle indoor units by approximately 5 dB.



	R32	R410A
AP-EEV32-S	1.5kW	-
AP-EEV32-M	2.2-7.1kW	1.5kW
AP-EEV	9.0kW	2.2-7.1kW

# Dimensions

All measurements in mm.

FDK15KXZE1-W, 22KXZE1-W, 28KXZE1-W, 36KXZE1-W, 45KXZE1-W, 56KXZE1-W  
 FDK15KXZE1, 22KXZE1, 28KXZE1, 36KXZE1, 45KXZE1, 56KXZE1

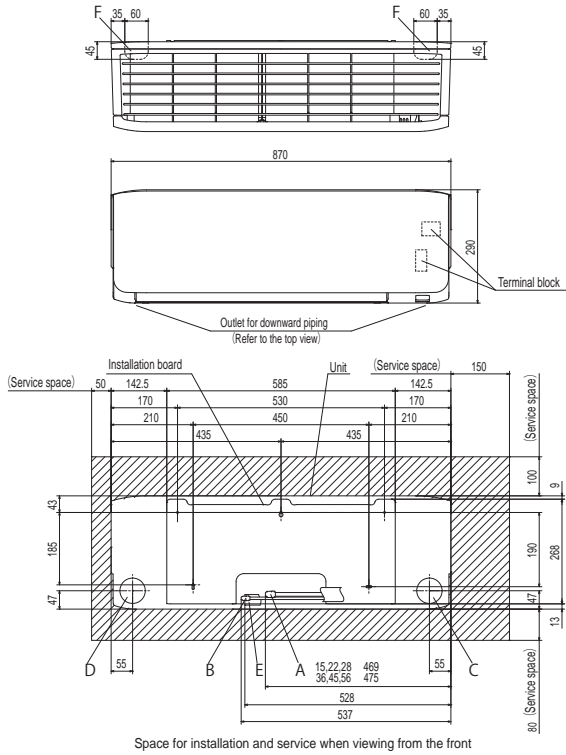

Symbol	Model	Content	
		15.22.28	36.45.56
A	Gas piping	φ9.52(3/8") (Flare)	φ12.7(1/2") (Flare)
B	Liquid piping	φ6.35(1/4") (Flare)	
C	Hole on wall for right rear piping	(φ65)	
D	Hole on wall for left rear piping	(φ65)	
E	Drain hose	VP16 (O.D.22)	
F	Outlet for wiring (on both side)		

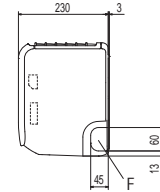

Note (1) The model name label is attached on the right side of the unit.

FDK71KXZE1-W, 90KXZE1-W  
 FDK71KXZE1, 90KXZE1

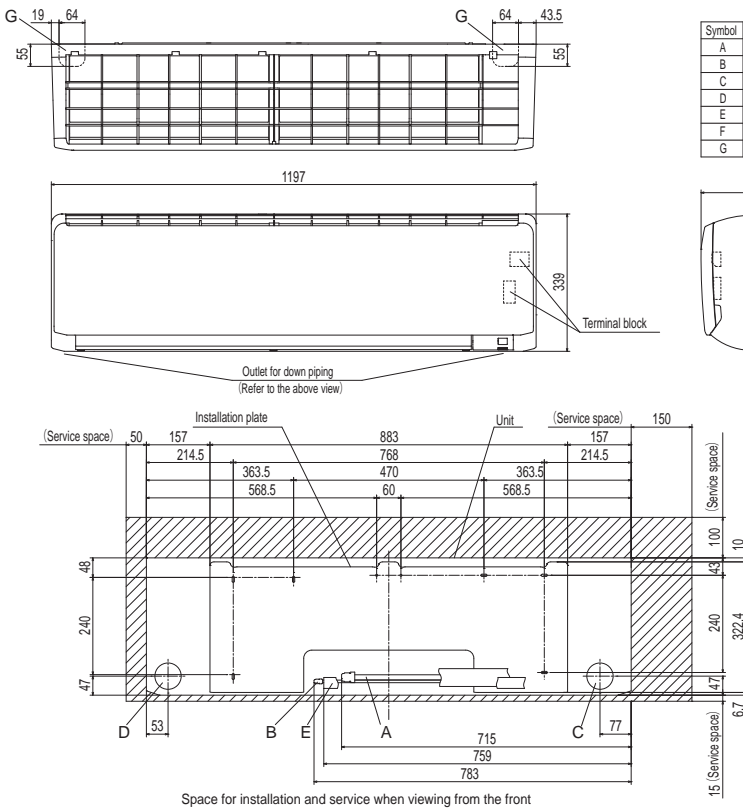

Symbol	Model	Content	
		15.22.28	36.45.56
A	Gas piping	φ15.88(5/8") (Flare)	
B	Liquid piping	φ9.52(3/8") (Flare)	
C	Hole on wall for right rear piping	(φ65)	
D	Hole on wall for left rear piping	(φ65)	
E	Drain hose	VP16 (O.D.22)	
F	Outlet for wiring (on both side)		
G	Outlet for piping (on both side)		

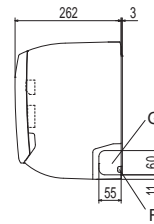

Note (1) The model name label is attached on the underside of the indoor unit.

# Ceiling Suspended FDE

## Model No.

- FDE36KXZE1
- FDE45KXZE1
- FDE56KXZE1
- FDE71KXZE1
- FDE112KXZE1
- FDE140KXZE1



## Remote control (option)

Wired



RC-EX3D RC-E5 RCH-E3

Wireless



RCN-E-E3

### Flap control system

Selection of flap position is possible. A flap can be set at different angles.

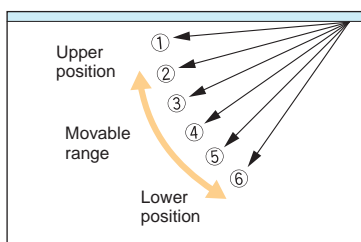

\*The wireless remote control is not applicable to the flap control system.

### Lighter than ever

By decreasing the number of fan motors from two to one, we reduced the overall weight of our FDE units.

	Previous		Current	
FDE71	37	➔	33	4kg less!!
FDE112	49	➔	43	6kg less!!
FDE140	49	➔	43	6kg less!!

### Reduction of sound pressure level (Lo mode)

We achieved the industry's lowest sound pressure levels by decreasing air flow volume, decreasing pressure loss with employment of one fan motor and optimising casing and distributor shape. (comparison of previous model)

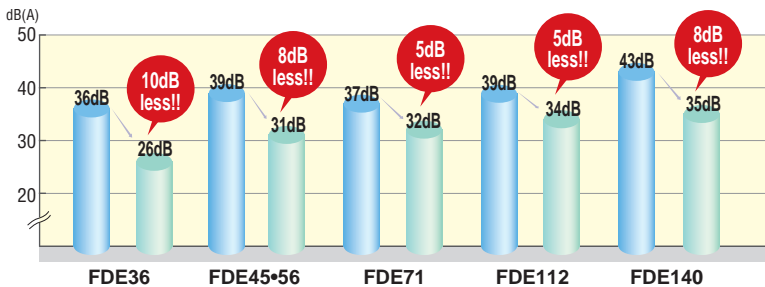

### Motion Sensor

(Option)

Reduce your environmental impact with our optional motion sensor feature.

By detecting presence or absence of human activity in a room, the motion sensor improves room comfort and unit energy saving performance.



LB-E

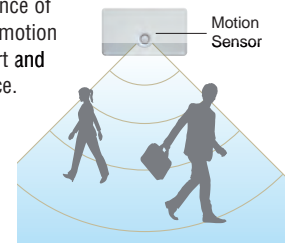

## Specifications

Item	Model	FDE36KXZE1	FDE45KXZE1	FDE56KXZE1	FDE71KXZE1	FDE112KXZE1	FDE140KXZE1
Nominal cooling capacity	kW	3.6	4.5	5.6	7.1	11.2	14.0
Nominal heating capacity	kW	4.0	5.0	6.3	8.0	12.5	16.0
Power source		1 Phase 220-240V, 50Hz					
Power consumption	Cooling	0.05-0.05			0.07-0.07	0.10-0.10	0.13-0.13
	Heating	0.05-0.05			0.07-0.07	0.10-0.10	0.13-0.13
Sound power level	dB(A)	60			62	61	64
Sound pressure level	dB(A)	P-Hi:46 Hi:38 Me:31 Lo:26	P-Hi:46 Hi:38 Me:36 Lo:31	P-Hi:46 Hi:38 Me:36 Lo:31	P-Hi:47 Hi:39 Me:37 Lo:32	P-Hi:45 Hi:42 Me:38 Lo:34	P-Hi:48 Hi:43 Me:40 Lo:35
Exterior dimensions H x W x D	mm	210 x 1070 x 690			210 x 1320 x 690	250 x 1620 x 690	
Net weight	kg	28			33	43	
Air flow	m <sup>3</sup> /min	P-Hi:13 Hi:10 Me:7 Lo:5.5	P-Hi:13 Hi:10 Me:9 Lo:7		P-Hi:20 Hi:15 Me:13 Lo:10	P-Hi:28 Hi:25 Me:21 Lo:16.5	P-Hi:32 Hi:26 Me:23 Lo:17
Outside air intake		Not possible					
Air filter, Q'ty		Pocket Plastic net x2 (Washable)					
Remote control(option)		wired:RC-EX3D, RC-E5, RCH-E3 wireless:RCN-E-E3					
Installation data	Refrigerant piping size	Liquid line:ø6.35(1/4") Gas line:ø12.7(1/2")			Liquid line:ø9.52(3/8") Gas line:ø15.88(5/8")		

1. The data are measured under the following conditions(ISO-T1). Cooling: Indoor temp. of 27°CDB, 19°CWB, and outdoor temp. of 35°CDB. Heating: Indoor temp. of 20°CDB, and outdoor temp. of 7°CDB, 6°CWB.  
2. Sound pressure level indicates the value in an anechoic chamber. During operation these values are somewhat higher due to ambient conditions.

# Dimensions

All measurements in mm.

## FDE36KXZE1, 45KXZE1, 56KXZE1

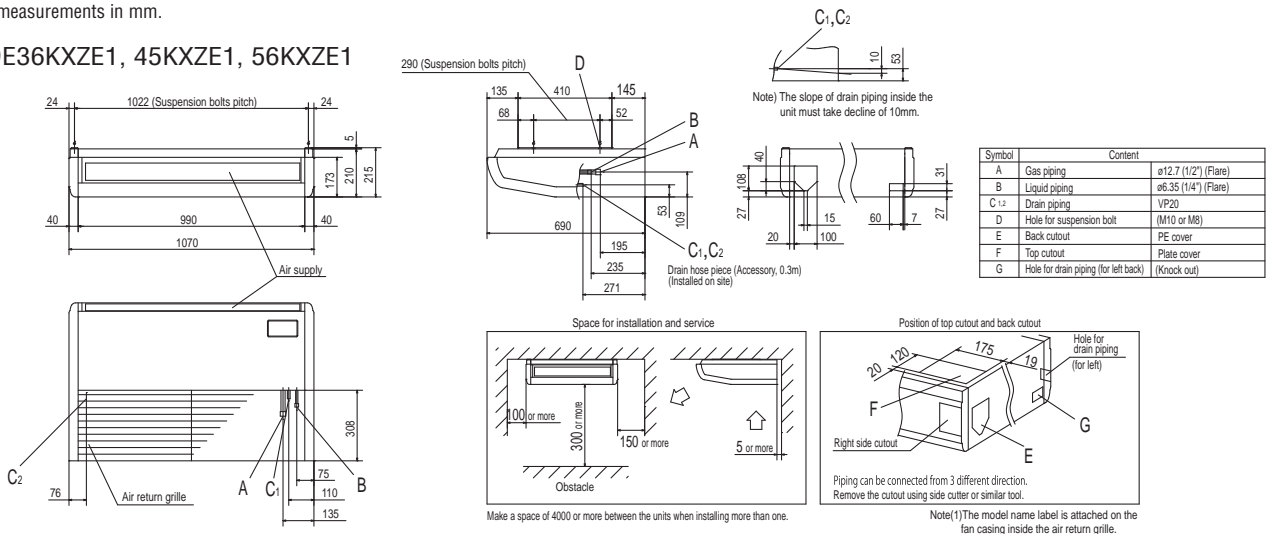

## FDE71KXZE1

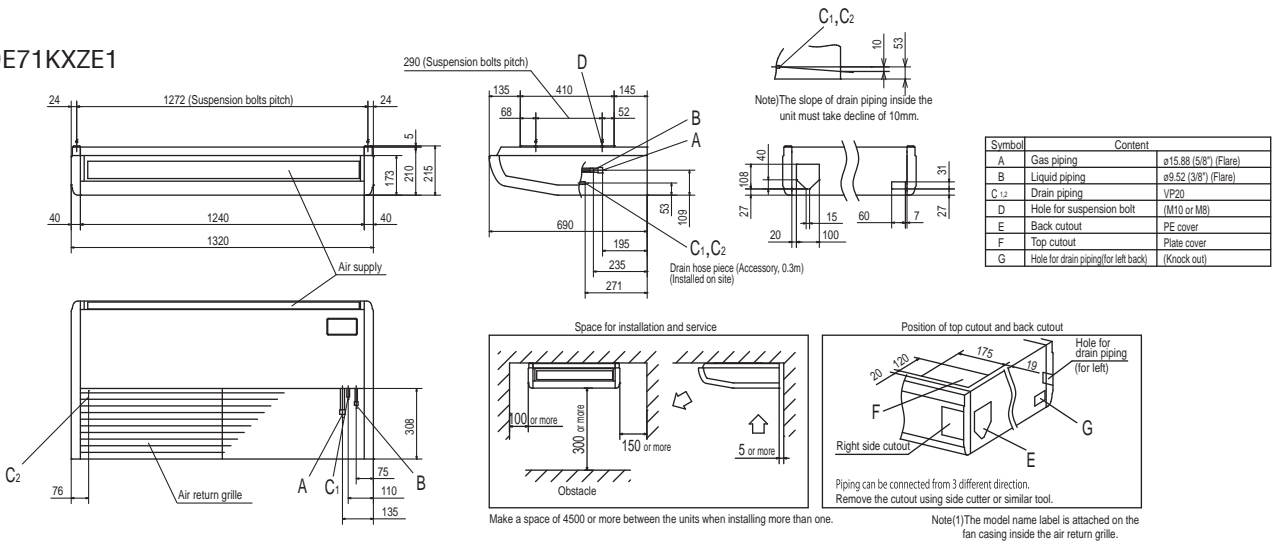

## FDE112KXZE1, 140KXZE1

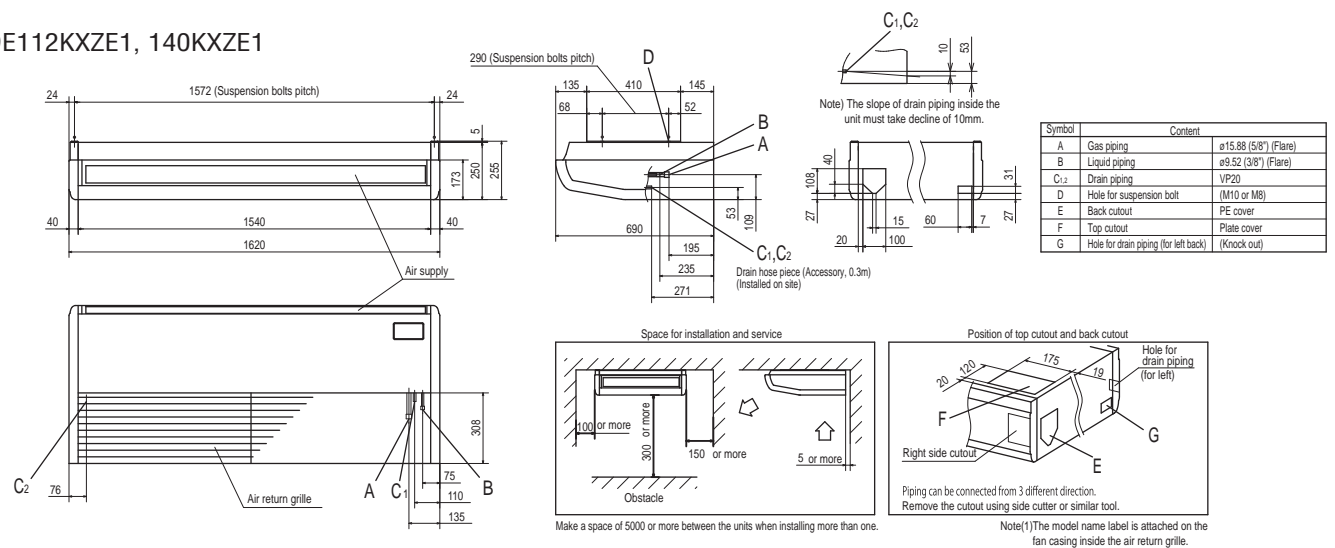

# Floor Standing -2way- FDFW

## Model No.

FDFW28KXE6F  
FDFW45KXE6F  
FDFW56KXE6F



## Auto air outlet selection



## Remote control (option)

Wired

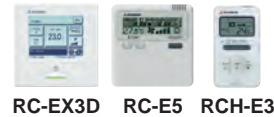

Wireless

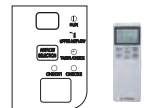

RCN-FW-E2

## Sophisticated Design

With an elegant semi flat front panel in stylish white, the new series fit in various kinds of rooms and create relaxing atmosphere. Choice of wall hanging, floor standing or behind gallery installation is available.

## Quiet Operation

Thanks to the optimum balance of air outlet direction and sufficient air flow volume, the sound level has been minimized. The level of FDFW28KXE6F in the cooling Lo mode is only 30dB(A).

## Flap control system

Selection of flap position is possible. A flap can be set at different angles.

\* The wireless remote control is not applicable to the flap control system.

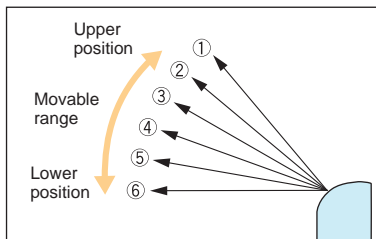

## Convenient to use operation

Simultaneous lower and upper air outlets or upper outlet can be selected by air flow direction button. Further control can be arranged by a remote control.

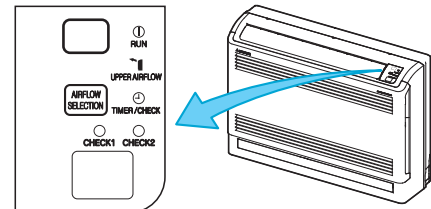

(In case of use of wireless remote control)

# Specifications

Item	Model	FDFW28KXE6F	FDFW45KXE6F	FDFW56KXE6F
Nominal cooling capacity	kW	2.8	4.5	5.6
Nominal heating capacity	kW	3.2	5.0	6.3
Power source		1 Phase 220-240V, 50Hz		
Power consumption	Cooling	0.02-0.02	0.02-0.02	0.03-0.03
	Heating	0.02-0.02	0.02-0.02	0.03-0.03
Sound power level	dB(A)	55	57	60
Sound pressure level	dB(A)	Hi:36 Me:34 Lo:30	Hi:38 Me:36 Lo:33	Hi:44 Me:37 Lo:33
Exterior dimensions H x W x D	mm	600x860x238		
Net weight	kg	19	20	
Air flow (Standard)	m <sup>3</sup> /min	Hi:9 Me:8 Lo:7		Hi:11 Me:9 Lo:8
Air filter, Q'ty		Polypropylene net x1 (Washable)		
Outside air intake		Not possible		
Remote control(option)		wired:RC-EX3D, RC-E5, RCH-E3 wireless:RCN-FW-E2		
Installation data Refrigerant piping size	mm(in)	Liquid line:ø6.35(1/4") Gas line:ø9.52(3/8")		Liquid line:ø6.35(1/4") Gas line:ø12.7(1/2")

1. The data are measured under the following conditions(ISO-T1). Cooling: Indoor temp. of 27°CDB, 19°CWB, and outdoor temp. of 35°CDB. Heating: Indoor temp. of 20°CDB, and outdoor temp. of 7°CDB, 6°CWB.  
2. Sound pressure level indicates the value in an anechoic chamber. During operation these values are somewhat higher due to ambient conditions.

# Dimensions

All measurements in mm.

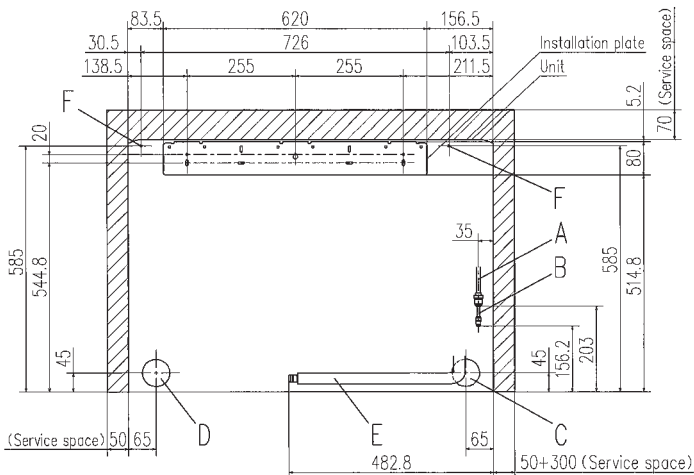
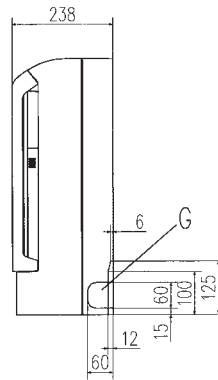
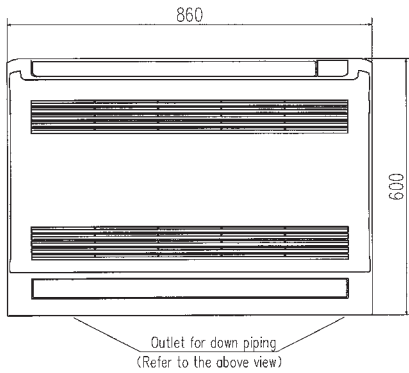
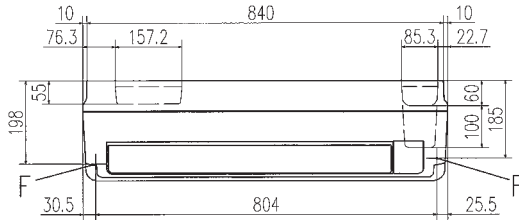

Space for installation and service when viewing from the front

Symbol	Content	
	Model	
A	Gas piping	FDW28KXE6F $\phi 9.52$ (3/8") (Flare) FDFW45KXE6F, 56KXE6F $\phi 12.7$ (1/2") (Flare)
B	Liquid piping	$\phi 6.35$ (1/4") (Flare)
C	Hole on wall for right rear piping	$\phi 65$
D	Hole on wall for left rear piping	$\phi 65$
E	Drain hose	VP16 (I.D.16)
F	Screw point fasten the indoor unit	$\phi 5$
G	Outlet for piping (on both side)	

Notes

- (1) The model name label is attached on the right side of the unit.
- (2) In case of wall installation, leave the unit 150mm or less from the floor.

# Floor Standing (with casing) FDFL

# Floor Standing (without casing) FDFU

### Model No.

FDFL71KXE6F

FDFU28KXE6F

FDFU45KXE6F

FDFU56KXE6F

FDFU71KXE6F



FDFL

### Remote control (option)

Wired



RC-EX3D



RC-E5



RCH-E3

Wireless



RCN-KIT4-E2



FDFU (concealed type)

### Improved comfort with the airflow from a wide outlet

With the 60 degrees angle of the airflow from the front to the upper side the comfort has increased.

Piping could be taken from the side and the bottom leading to an improved serviceability and ease of installation



Wider air flow for optimum comfort



### Available in two types

The unit could be chosen from non concealed type and concealed type depending on the installation conditions

Compact design at 630mm height

### Motion Sensor

(Option)

The optional motion sensor on our floor standing units saves energy by operations by detecting human movement. Our smart technology provides energy saving control by shifting set temperature by detecting human activity.



LB-KIT2

## Specifications

Item	Model	FDFL71KXE6F	FDFU28KXE6F	FDFU45KXE6F	FDFU56KXE6F	FDFU71KXE6F
Nominal cooling capacity	kW	7.1	2.8	4.5	5.6	7.1
Nominal heating capacity	kW	8.0	3.2	5.0	6.3	8.0
Power source		1 Phase 220-240V, 50Hz				
Power consumption	Cooling	0.09-0.10				
	Heating	0.09-0.10				
Sound power level	dB(A)	62	58	60		
Sound pressure level	dB(A)	Hi:43 Me:41 Lo:40	Hi:41 Me:38 Lo:36	Hi:43 Me:41 Lo:40		
Exterior dimensions H x W x D	mm	630x1481x225	630x1087x225			630x1372x225
Net weight	kg	40	25			32
Air flow (Standard)	m <sup>3</sup> /min	Hi:18 Me:15 Lo:12	Hi:12 Me:11 Lo:10	Hi:14 Me:12 Lo:10		Hi:18 Me:15 Lo:12
Air filter, Q'ty		Polypropylene net x1 (Washable)				
Remote control(option)		wired:RC-EX3D, RC-E5, RCH-E3 wireless:RCN-KIT4-E2				
Installation data Refrigerant piping size	mm(in)	Liquid line:ø9.52(3/8") Gas line:ø15.88(5/8")	Liquid line:ø6.35(1/4") Gas line:ø9.52(3/8")	Liquid line:ø6.35(1/4") Gas line:ø12.7(1/2")		Liquid line:ø9.52(3/8") Gas line:ø15.88(5/8")

1. The data are measured under the following conditions(ISO-T1). Cooling: Indoor temp. of 27°CDB, 19°CWB, and outdoor temp. of 35°CDB. Heating: Indoor temp. of 20°CDB, and outdoor temp. of 7°CDB, 6°CWB.  
2. Sound pressure level indicates the value in an anechoic chamber. During operation these values are somewhat higher due to ambient conditions.

# Dimensions

All measurements in mm.

## FDL

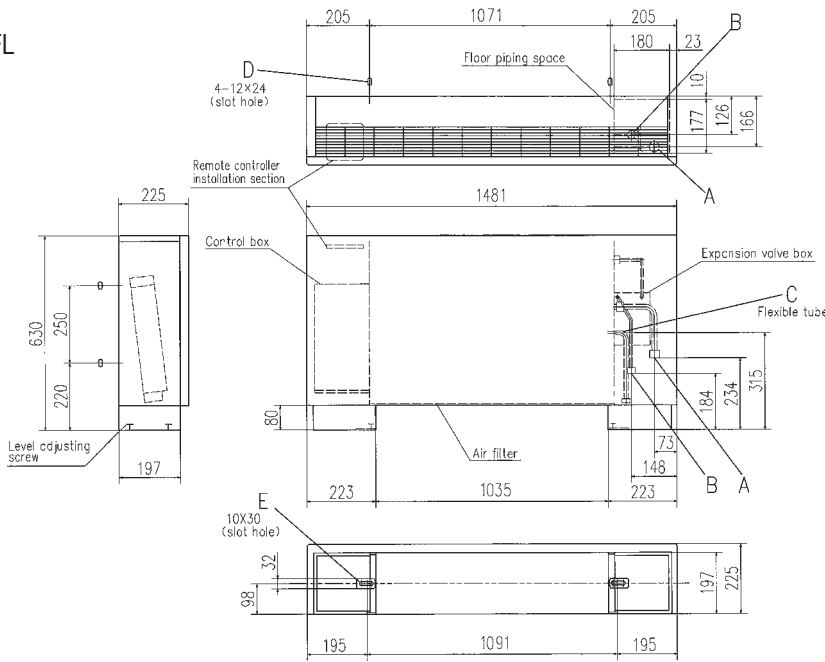

Symbol	Model	Content
		FDL71KXE6F
A	Gas piping (Accessory)	ø15.88 (3/8") (Flare)
B	Liquid piping	ø9.52 (3/8") (Flare)
C	Drain piping (Accessory)	PT20A female screw, 360mm
D	Slot hole for wall mounting	(M10)
E	Metal plate for floor mounting (Accessory)	(M8)

Note (1) The model name label is attached on the lid of the control box.

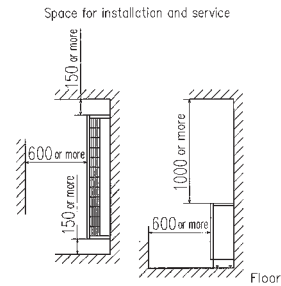

## DFU

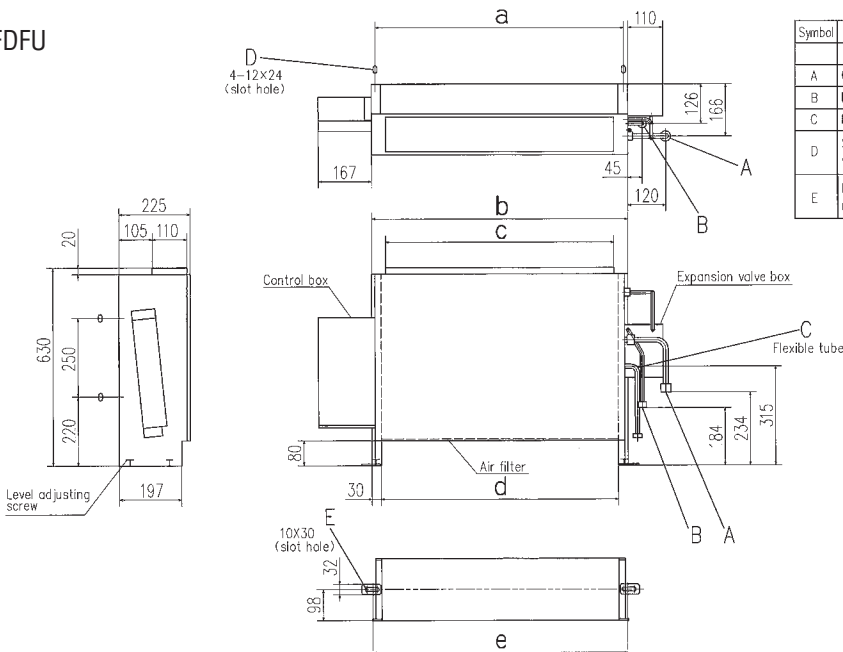

Symbol	Model	Content		
		DFU28KXE6F	DFU45KXE6F, 56KXE6F	DFU71KXE6F
A	Gas piping (Accessory)	ø9.52 (3/8") (Flare)	ø12.7 (1/2") (Flare)	ø15.88 (5/8") (Flare)
B	Liquid piping	ø6.35 (1/4") (Flare)		ø9.52 (3/8") (Flare)
C	Drain piping (Accessory)	PT20A female screw, 360mm		PT20A female screw, 360mm
D	Slot hole for wall mounting	(M10)		(M10)
E	Metal plate for floor mounting (Accessory)	(M8)		(M8)

Note (1) The model name label is attached on the lid of the control box.

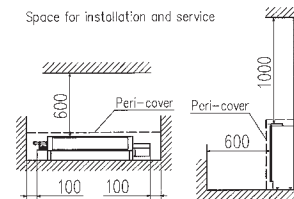

## Dimension Table

model	a	b	c	d	e
DFU28KXE6F, 45KXE6F, 56KXE6F	786	810	722	750	806
DFU71KXE6F	1071	1095	1007	1035	1091

Unit:mm

# Outdoor Air Processing unit FDU-F

## Model No.

FDU650FKXZE1  
FDU1100FKXZE1  
FDU1800FKXZE1  
FDU2400FKXZE1



## Remote control (option)

### Wired



RC-EX3D RC-E5 RCH-E3

### Wireless



RCN-KIT4-E2

## Create a fresher environment with the Outdoor Air Processing feature

Connect your KXZ system to an Outdoor Air Processing unit with one streamlined system. This advanced technology allows you to enjoy a fresh and comfortable air supply.

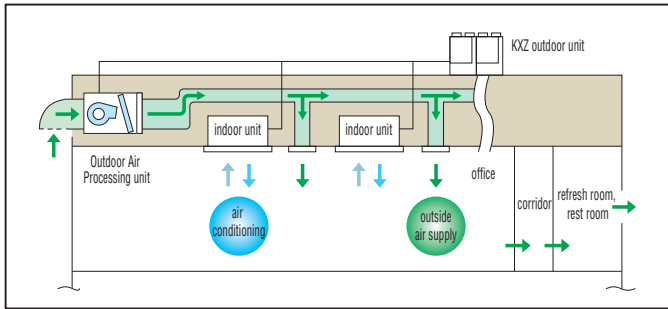

## Motion Sensor

(Option)

Built into the ceiling or wall plane, our motion sensor smart technology improves energy saving performance and overall room comfort.



LB-KIT2

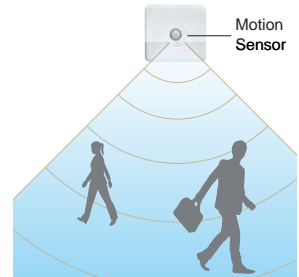

## Compact design

Compact design at just 280(650, 1100), 379(1800, 2400)mm in height, high static pressure of 200Pa and the industry's lowest noise level can meet various kind of installation locations for offices, refresh rooms, restrooms and kitchens of restaurants etc.

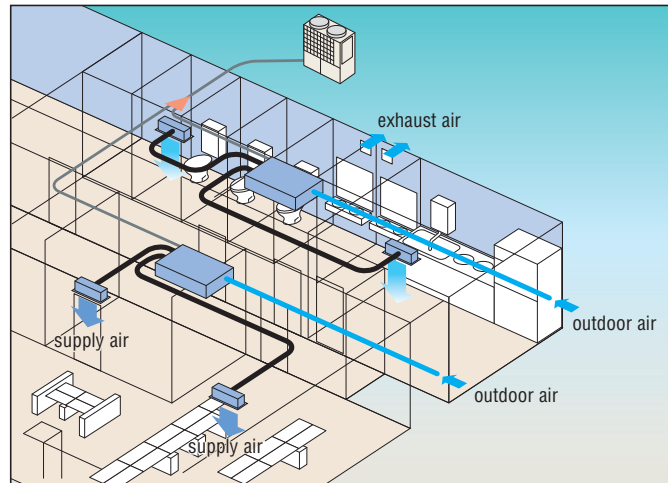

- (1) This unit is the specific unit for processing the outdoor air temperature closer to the room temperature. For conditioning the room temperature a dedicated air conditioner is required additionally.
- (2) This unit monitors the outdoor air temperature and controls the thermostat's ON/OFF at the setting temperature by the remote controller, which indicates the outdoor air temperature for controlling the thermostat's ON/OFF. When the thermostat is turned OFF, the operation is changed to the fan mode so that unprocessed outdoor air will be blown into the room directly. Therefore place the air outlet port or orient the air outlet direction not to blow air directly to persons in the room, especially in small room such as a restroom and/or sanitary hot water supplying room.
- (3) It is strictly prohibited to monitor the room temperature by switching to the thermistor at the remote controller side and/or the optional remote thermistor. Otherwise dew formation at air outlet port and/or dew dripping may occur during cooling operation due to the lower outdoor air temperature. Therefore keep the remote controller of this unit in place closer to the administrator so as not to be touched freely by the end user.
- (4) Dehumidifying operation with this unit is prohibited.
- (5) When handing over this unit to the end user, make sure to explain sufficiently about the foregoing cautions, the installation place and usage of remote control for this unit and the location of the air outlet.

## Connectivity with Outdoor units

FDU-F series are connectable to 8-60HP KXZ outdoor units, can not be connected to Micro KX (4-6HP), KXZ Lite.

## Combination with Outdoor units

	case	Combination
A	Only OA processing units are connected with outdoor units.	The total capacity of FDU-F is 50-100% of outdoor capacity and max quantity of FDU-F is 2 units.
B	Both of OA processing units and dedicated air conditioner are connected with outdoor units.	The total capacity of FDU-F and dedicated air conditioners is 50-100% of outdoor capacity and max quantity of FDU-F should be below 30% of outdoor unit capacity.

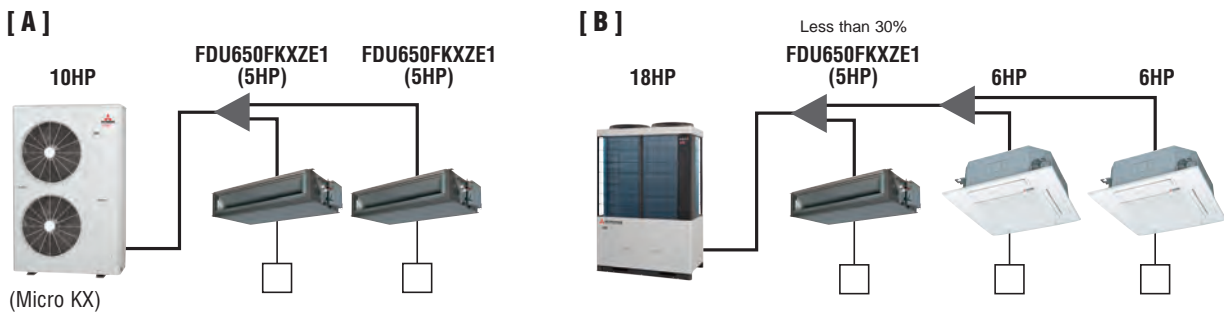

## Concept (Difference between FDU-F and SAF)

SAF is the energy recovery ventilation unit which can recover heat energy from exhaust air to supply air and "has no air processing function, but FDU-F is an air processing unit which can treat the supply air closer to room temperature by cooling or heating in connection with KXZ refrigerant system and exhaust air is discharged to outside of the room.

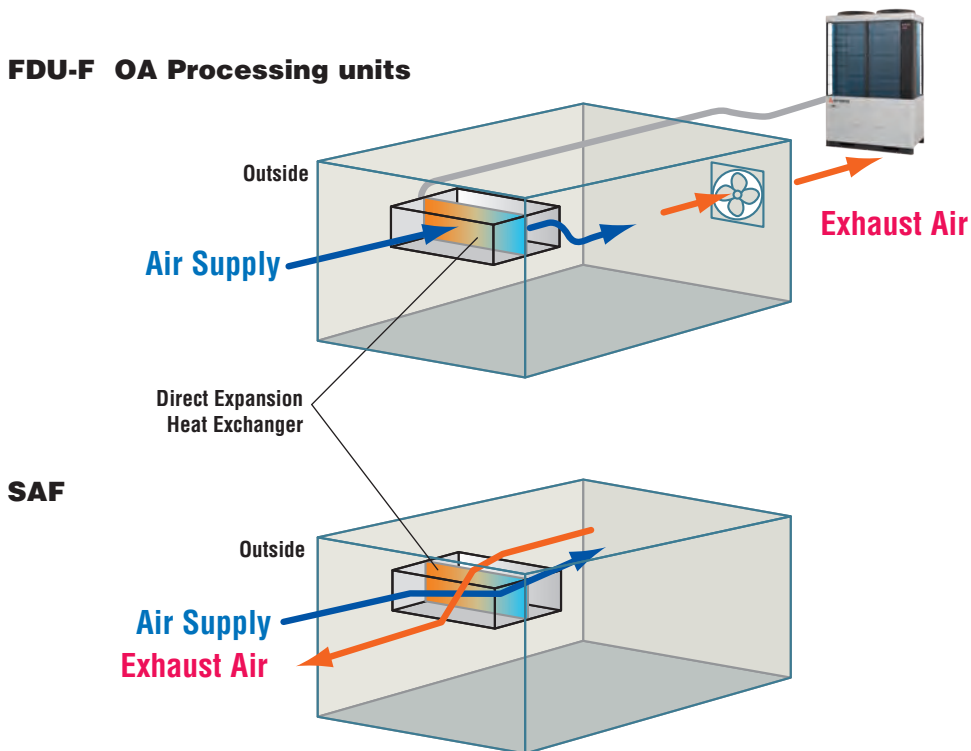

# Specifications

Item	Model	FDU650FKXZE1	FDU1100FKXZE1	FDU1800FKXZE1	FDU2400FKXZE1
Nominal cooling capacity	kW	9.0	14.0	22.4	28.0
Nominal heating capacity	kW	6.5	10.5	16.0	21.5
Power source		1 Phase 220-240V, 50Hz			
Power consumption	Cooling	0.24-0.25	0.35-0.36	1.16-1.20	1.16-1.20
	Heating	0.24-0.25	0.35-0.36	1.16-1.20	1.16-1.20
Sound pressure level	dB(A)	Hi:31	Hi:37	Hi:42	Hi:45
Exterior dimension HxWxD	mm	280x950x635	280x1368x740	379x1600x893	
Net weight	kg	34	54	89	89
Air flow (Standard)	m <sup>3</sup> /min	Hi:11	Hi:18	Hi:30	Hi:40
External static pressure	Pa	200 (at Hi Air flow)			
Air filter, Q <sub>ty</sub>		Procure locally			
Remote control(option)		wired:RC-EX3D, RC-E5, RCH-E3 wireless:RCN-KIT4-E2			
Installation data	mm	Liquid line:ø9.52(3/8")		Liquid line:ø9.52(3/8")	
Refrigerating piping size	(in)	Gas line:ø15.88(5/8")		Gas line:ø19.05(3/4")	

- The data are measured at 33°CDB 28°CWB (68%RH) during cooling and 0°CDB-2.9°CWB (50%RH) during heating (no frost).
- Temperature range of outdoor air must be 20–40°CDB (32°CWB) during cooling and 0–24°CDB during heating.
- Sound level indicates the value in an anechoic chamber. During operation these value are somewhat higher due to ambient conditions.
- The factory E.S.P. setting is set within the range of 10 - 120Pa. If SW8-4 is turned to "ON", E.S.P. setting range can be changed to 10 - 200 Pa. (with RC-EX3D and RC-E5 only)

# Dimensions

All measurements in mm.

## FDU650FKXZE1

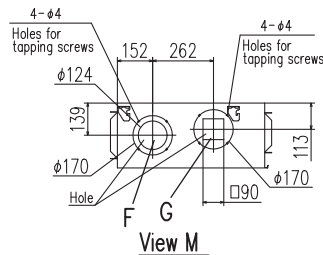
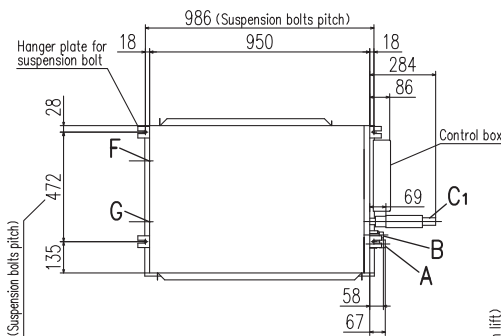
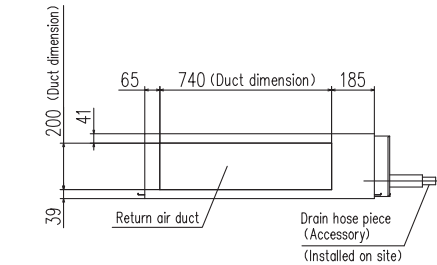

Symbol	Content	
A	Gas piping	ø15.88 (5/8") (Flare)
B	Liquid piping	ø9.52 (3/8") (Flare)
C1	Drain piping	VP25(O.D.32)
C2	Drain piping(Gravity drainage)	V20(O.D.26)
D	Hole for wiring	
E	Suspension bolts	M10
F	Outside air opening for ducting	(Knock out)
G	Air outlet opening for ducting	(Knock out)
H	Inspection opening	(450X450)

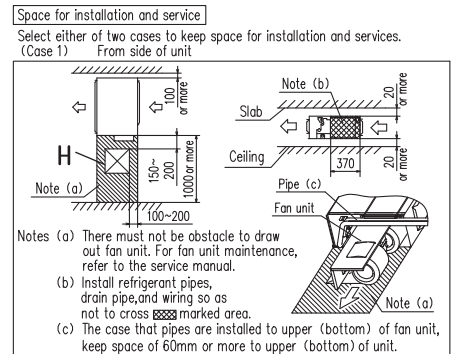

FDU1100FKXZE1

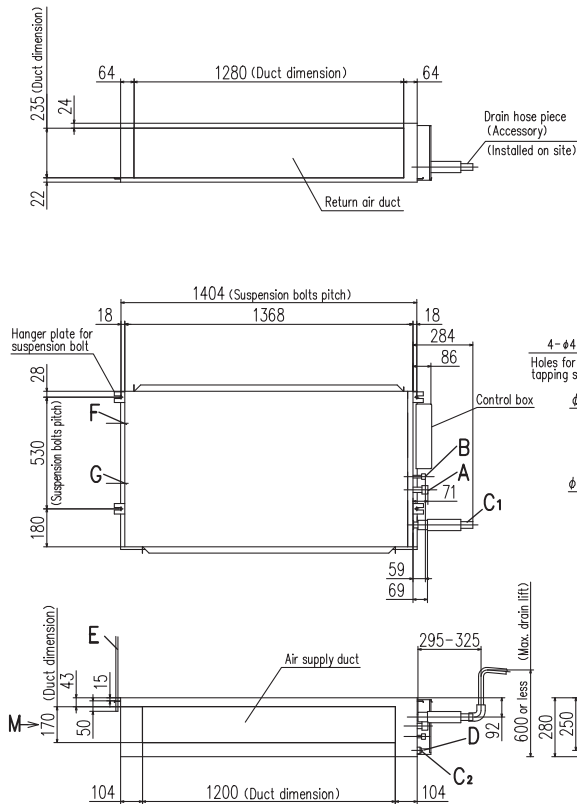

Symbol	Content	
A	Gas piping	ø15.88 (5/8") (Flare)
B	Liquid piping	ø9.52 (3/8") (Flare)
C1	Drain piping	VP25(O.D.32)
C2	Drain piping(Gravity drainage)	V20(O.D.26)
D	Hole for wiring	
E	Suspension bolts	M10
F	Outside air opening for ducting	(Knock out)
G	Air outlet opening for ducting	(Knock out)
H	Inspection opening	(450X450)

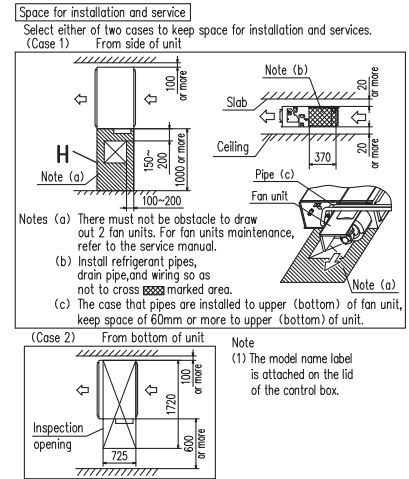

FDU1800FKXZE1, FDU2400FKXZE1

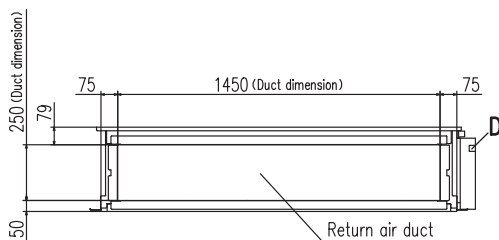

Symbol	Content	MODEL	
		1800	2400
A	Gas piping	ø19.05 (3/4")	ø22.22 (7/8")
B	Liquid piping	ø9.52 (3/8") (Brazing)	
C	Drain piping(Gravity drainage)	VP25(O.D.32)	
D	Hole for wiring		
E	Suspension bolts	M10	
F	Inspection hole	(450X450)	

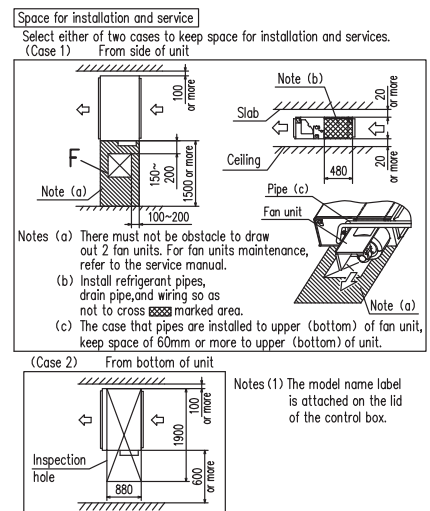
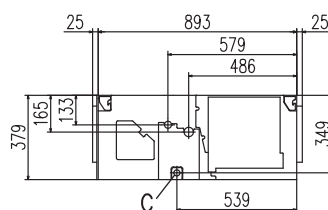
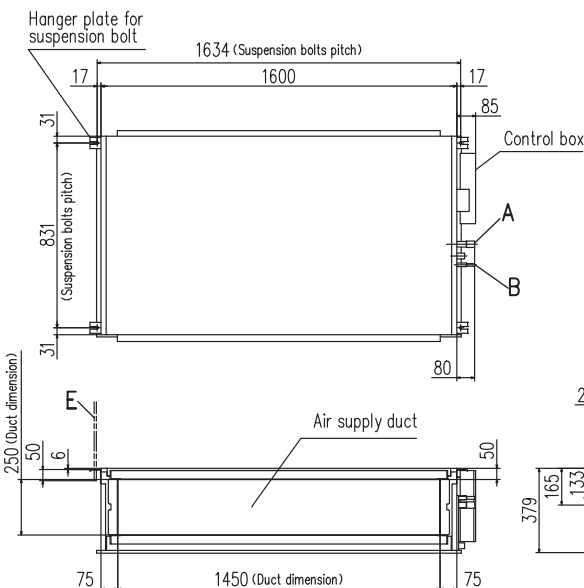

# Ventilation

## Fresh Air Ventilation and Heat Exchange unit SAF-E7

**Model No.**  
SAF150E7  
SAF250E7  
SAF350E7  
SAF500E7  
SAF800E7  
SAF1000E7



### Energy Performance of Building Directive - EPBD

The EPBD function limits electrical/gas power to provide heating or cooling to commercial buildings. To use this function, the building designer needs to select energy efficient heating/cooling equipment and to minimise energy losses through ventilation systems.

SAF smart technology recovers heat energy in the atmosphere which would have otherwise been lost. It then uses this energy to warm air entering the building. The reverse happens in warmer climates where the exhausted cool air is used to partially cool the incoming air.

Helping you to reduce energy consumption and carbon emissions by capturing waste energy. EPBD also allows for smaller sized units as less heating/cooling requirements are needed!

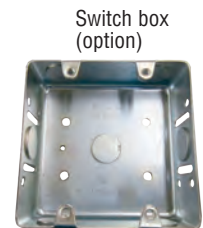
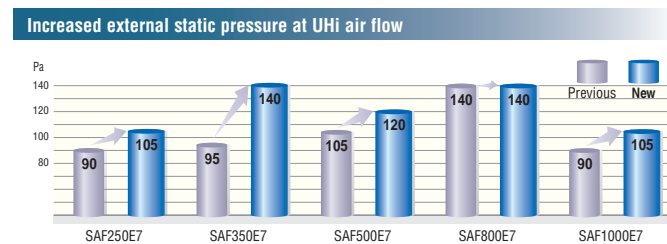

#### Remote control

The following functions are newly available.

- ON/OFF Timer – The hour and minute of timer on/off can be set.
- Filter Sign – Announces the due time for cleaning the air filter.

## Specifications

Item	Model	SAF150E7	SAF250E7	SAF350E7	SAF500E7	SAF800E7	SAF1000E7		
Power source		1 Phase 220-240V, 50Hz							
Exterior dimensions Height x Width x Depth	mm	270x970x467	270x882x599	317x1050x804	317x1090x904	388x1322x884	388x1322x1134		
Exterior appearance		Galvanized steel sheet							
Power input	W	92-107	108-123	178-185	204-225	360-378	416-432		
Running current	A	0.42-0.45	0.49-0.51	0.81-0.77	0.93-0.94	1.64-1.58	1.89-1.80		
Capacity	UHi	Enthalpy exchange efficiency	Cooling	63	63	66	62	65	65
		Heating	70	70	69	67	71	71	
	Hi	Temperature exchange efficiency	75						
		Enthalpy exchange efficiency	Cooling	63	63	66	62	65	65
	Heating	70	70	69	67	71	71		
	Lo	Temperature exchange efficiency	75						
		Enthalpy exchange efficiency	Cooling	66	65	71	64	68	70
	Heating	73	72	73	69	74	76		
Temperature exchange efficiency	77	77	78	76	76	79			
Motor & Q'ty	W	10 x 2	20 x 2	40 x 2	70 x 2	180 x 2	180 x 2		
Air handling equipment Fan type & Q'ty		Sirocco fan x 2							
Air flow	UHi	150	250	350	500	800	1000		
	Hi	150	250	350	500	800	1000		
	Lo	120	190	240	440	630	700		
External static pressure	UHi	80	105	140	120	140	105		
	Hi	70	95	60	60	110	80		
	Lo	25	45	45	35	55	75		
Net weight	kg	25	29	49	57	71	83		
Remote control		Included							
Air filter	Supply air	Protection for element (Washable) PS400							
	Exhaust air								

(1) The data are measured at the following conditions.

		Summer	Winter
Indoor side (Supply air)	DB	27°C	20°C
	WB	20°C	14°C
Outdoor side (Outside air)	DB	35°C	5°C
	WB	29°C	2°C
Unit around	DB	27°C	20°C

Structure (SAF800E7)

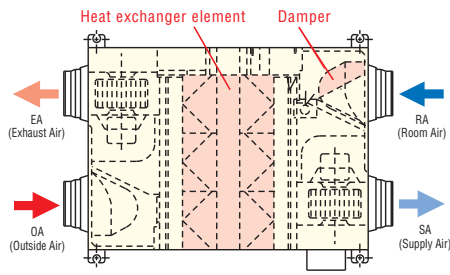

Principle of operation (simple ventilation)

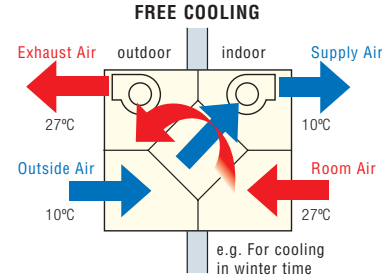

Principle of operation (heat exchanging)

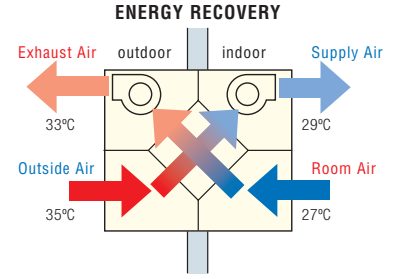

## Dimensions

All measurements in mm.

SAF150E7, SAF250E7, SAF350E7, SAF500E7

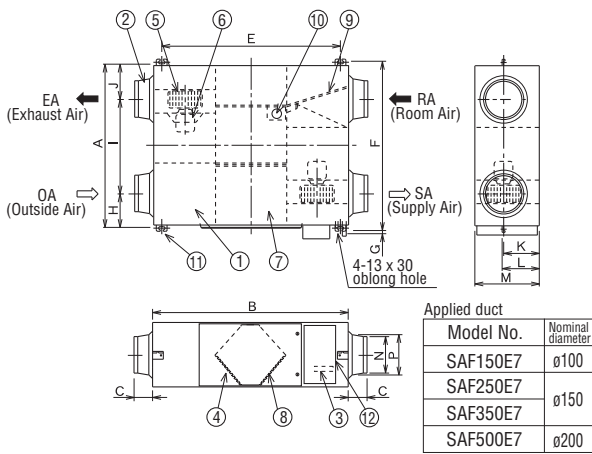

SAF800E7, SAF1000E7

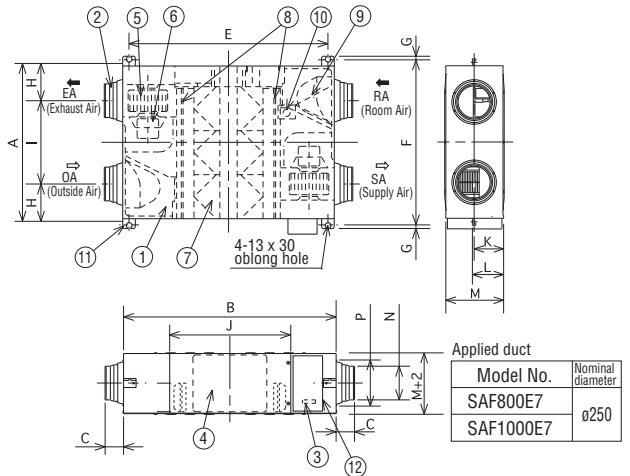

Dimension table

Model	A	B	C	E	F	G	H	I	J	K	L	M	N	P
SAF150E7	467	970	49	810	525	19	82	303	82	135	159	270	ø98	ø110
SAF250E7	599	882	95	810	655		142	315	142	159	270	ø144	ø164	
SAF350E7	804	1050	70	978	860	112	580	112	159	182	317	ø194	ø210	
SAF500E7	904	1090		1018	960	132	640	132						

Dimension table

Model	A	B	C	E	F	G	H	I	J	K	L	M	N	P
SAF800E7	884	1322	85	1250	940	19	228	428	612	194	218	388	ø242	ø258
SAF1000E7	1134				1190			678						

NO.	Name	Qt'y
①	Frame	1
②	Adaptor	4
③	Terminal board	1
④	Inspection Cover	1
⑤	Fan	2 ※
⑥	Motor	2 ※
⑦	Heat Exchange Element	
	SAF150E7	1
	SAF250E7	1
	SAF350E7	2
	SAF500E7	2
⑧	Filter	2
	SAF800E7	3
⑨	Damper	1
	SAF1000E7	4
⑩	Damper Motor	1
⑪	Suspension fitting	4
⑫	Electrical components box	1

※Model SAF350E7, SAF500E7 have different fan and motor locations.

### Installation reference

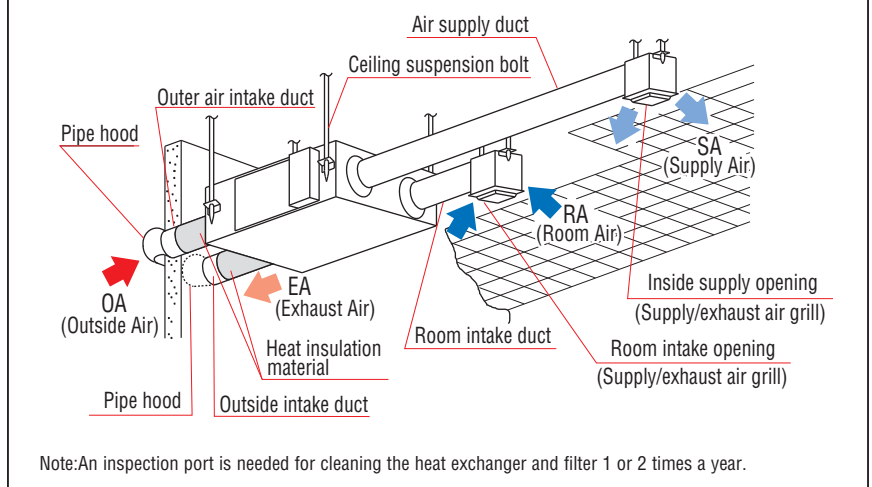

Note: An inspection port is needed for cleaning the heat exchanger and filter 1 or 2 times a year.

# Fresh Air DX Assembly

## SAF-DX

### Model No.

SAF-DX250E6  
SAF-DX350E6  
SAF-DX500E6  
SAF-DX800E6  
SAF-DX1000E6



Drain up kit (option)  
**DXA-DU-E**  
(built-in type)

### Remote control (option)

Wired



RC-E5

RCH-E3

Wireless



RCN-KIT4-E2

- SAF-DX is a heating or cooling coil incorporating KXZ series controls. It can be used in combination with our total heat exchanger. (SAF series)
- Combination of SAF-DX with other indoor units is possible. The capacity code index of each model is shown below and must be used when making the system selection. Total capacity code index must be within 100% of outdoor unit capacity code index.
- Remote control option is the same as other indoor units (see above). Connection to all Superlink controls is also possible.
- Optional condensate lift mechanism is also available (600mm height).
- Return air temp. control or supply air temp. control can be selected.

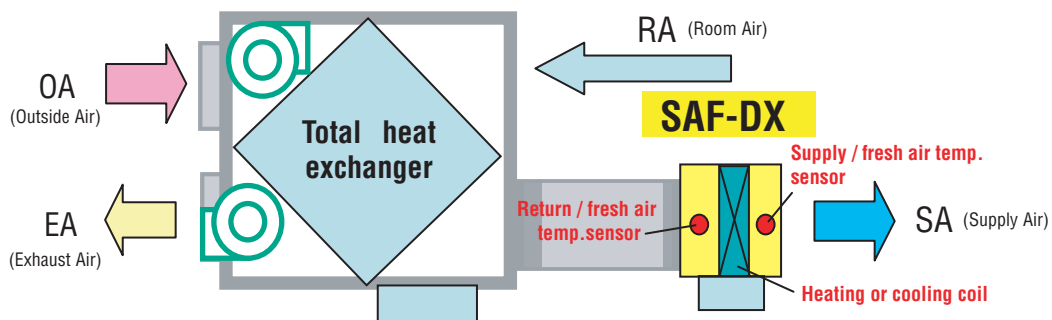

SAF-DX can provide heating or cooling to the fresh air supplied through a 3rd party air handling unit or total heat exchanger such as our SAF series.

## Specifications

Item	Model	SAF-DX250E6	SAF-DX350E6	SAF-DX500E6	SAF-DX800E6	SAF-DX1000E6
Nominal cooling capacity *1	KW	2.0	2.8	3.6	5.6	6.3
Nominal heating capacity *2	KW	1.8	2.2	2.8	4.5	5.6
Capacity code		22	28	36	56	71
Power source		1 Phase 220-240V, 50Hz				
Power consumption	Cooling	7.2-7.2				
	Heating	7.2-7.2				
Running current	Cooling	0.05-0.05				
	Heating	0.05-0.05				
Exterior dimensions H x W x D	mm	315 x 452 x 422		315 x 537 x 422	315 x 682 x 422	315 x 822 x 422
Net weight	kg	12.3		13.6	16.1	18.4
Air flow (Standard)	m <sup>3</sup> /h	250	350	500	800	1000
Internal resistance	Pa	38		66		
Remote control(option)		wired: RC-E5, RCH-E3 wireless: RCN-KIT4-E2				
Installation data Refrigerant piping size	mm(in)	Liquid line:ø6.35(1/4") Gas line:ø9.52(3/8")		Liquid line:ø6.35(1/4") Gas line:ø12.7(1/2")		Liquid line:ø9.52(3/8") Gas line:ø15.88(5/8")

(1) The data are measured at the following conditions.

Item	Return/fresh air temperature		Outdoor air temperature		Standards
	DB	WB	DB	WB	
Cooling*1	27°C	19°C	35°C	24°C	ISO-T1
Heating*2	20°C		7°C	6°C	

(2) This air conditioner is manufactured and tested in conformity with ISO-T1 'UNITARY AIR CONDITIONERS'.

# Dimensions

All measurements in mm.

## SAF-DX250E6,350E6

Symbol	Content
A	Gas piping $\varnothing 9.52 (3/8")$ (Flare)
B	Liquid piping $\varnothing 6.35 (1/4")$ (Flare)
C	Drain piping R1
D	Hole for power source line
E	Wiring hole for total enthalpy heat exchanger
F	Hole for communication line
G	Suspension bolts M10

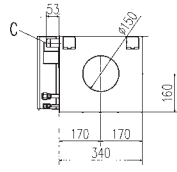

Space for installatin and service

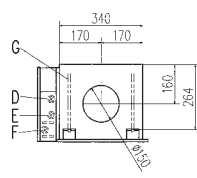
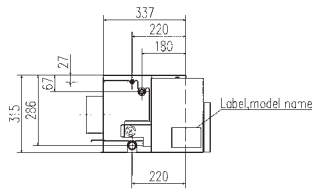
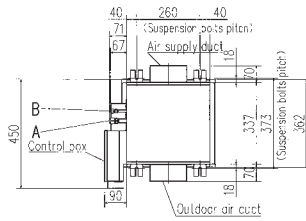
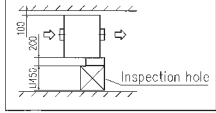

## SAF-DX500E6

Symbol	Content
A	Gas piping $\varnothing 27 (1/2")$ (Flare)
B	Liquid piping $\varnothing 6.35 (1/4")$ (Flare)
C	Drain piping R1
D	Hole for power source line
E	Wiring hole for total enthalpy heat exchanger
F	Hole for communication line
G	Suspension bolts M10

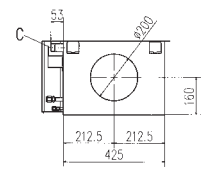

Space for installatin and service

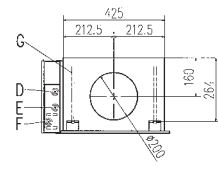
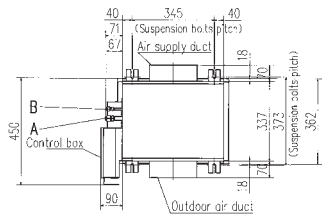
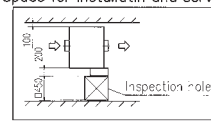

## SAF-DX800E6

Symbol	Content
A	Gas piping $\varnothing 27 (1/2")$ (Flare)
B	Liquid piping $\varnothing 6.35 (1/4")$ (Flare)
C	Drain piping R1
D	Hole for power source line
E	Wiring hole for total enthalpy heat exchanger
F	Hole for communication line
G	Suspension bolts M10

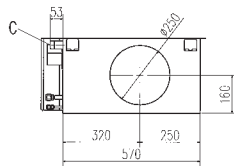

Space for installatin and service

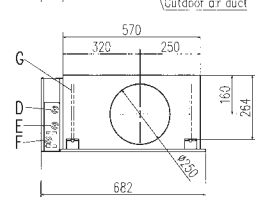
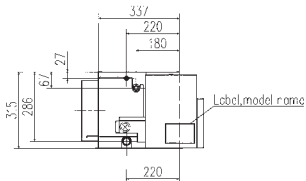
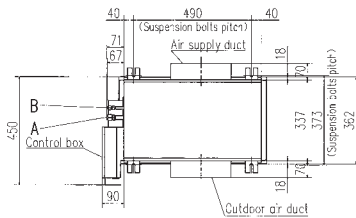
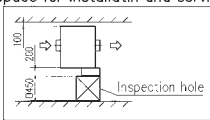

## SAF-DX1000E6

Symbol	Content
A	Gas piping $\varnothing 50.8 (2")$ (Flare)
B	Liquid piping $\varnothing 9.52 (3/8")$ (Flare)
C	Drain piping R1
D	Hole for power source line
E	Wiring hole for total enthalpy heat exchanger
F	Hole for communication line
G	Suspension bolts M10

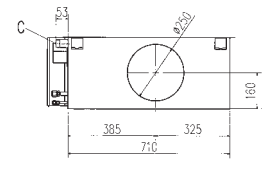

Space for installatin and service

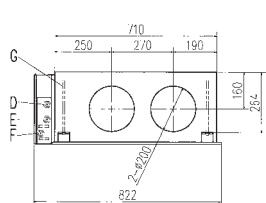
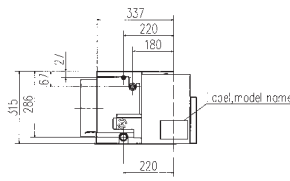
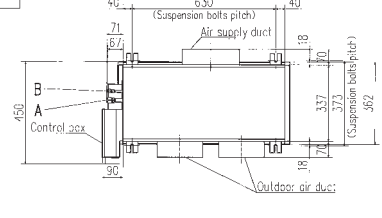
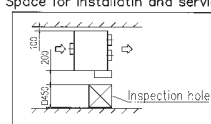

# Electronic Expansion Valve Kit

EEV-KIT 

- EEV-KIT is the control kit for operating the locally provided AHU or FCU with direct expansion heat exchanger coils in connection with the KXZ system.  
(AHU : Air Handling Unit, FCU : Fan Coil Unit)
- EEV-KIT is composed of one EEV-Control ASSY and one EEV-Set.

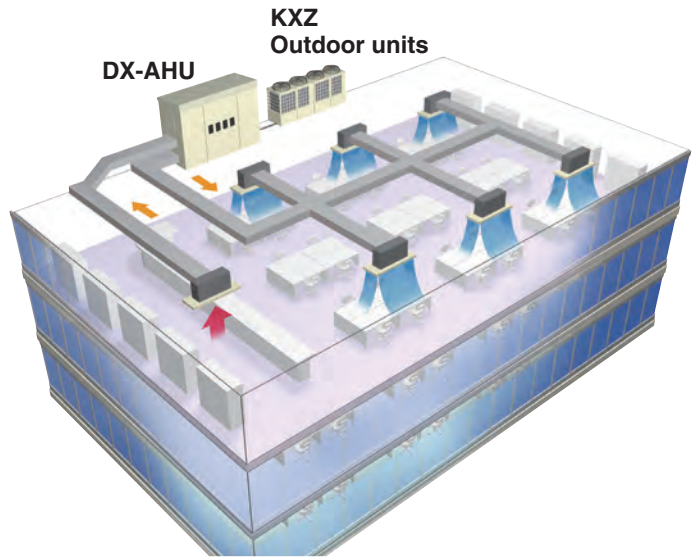
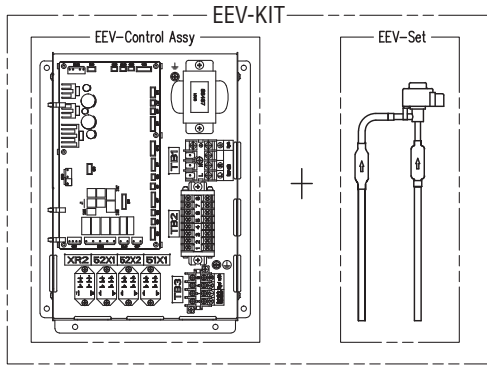

DX : Direct expansion coil

## Features

EEV-Control Assy has 2 types.

Refrigeration system	EEV-Control Assy	
	EEVKIT6-E-M	EEVKIT6-E-C
Single		1 box-Many boxes
Multiple	1 box (for master)	Many boxes(for slave)

EEV-Set Select from following 3 types according to the coil capacity.

Type	EEV6-71-E	EEV6-160-E	EEV6-280-E
Capacity	22-71	90-160	224-280

## System configuration

- Single refrigeration system EEVKIT6-E-C ... Possible with multiple refrigeration systems
- Multiple refrigeration system EEVKIT6-E-M (1) + EEVKIT6-E-C ... Possible with multiple refrigeration systems(Max32)
- EEVKIT6-E-C is common for both single and multiple refrigeration systems

## Single refrigerant system

- Single refrigeration system is the one that can have multiple outdoor units on one refrigerant pipe work circuit.
- There are 2 types of EEV-KIT systems that can be built into the single refrigeration system.
- System A : one EEV-KIT.
- System B : multiple EEV-KIT's.

### System A

- This system has only one set of EEV-KIT built into one indoor unit with only one heat exchanger. This system can be applied to an indoor unit whose capacity is up to 10HP.

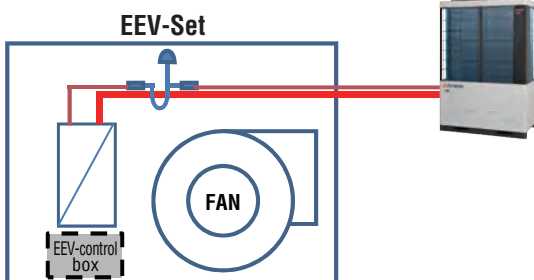

### System B

- System B is a system that has multiple EEV-KIT's built into one indoor unit with multiple heat exchangers on one refrigerant circuit.
- This system can be applied up to 60HP (for KXZ) AHU capacity.

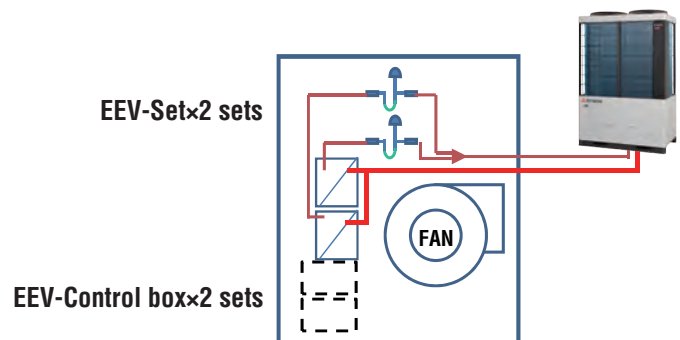

# Multiple refrigerant system

Multiple refrigeration system is an AHU system with multiple independent refrigerant circuits and one master control to control the whole system.

## Advantages

- Large systems are possible [max capacity 896kW ]
- External control
- Capacity step control
- Can connect to 32 units

## Additional parts over a single refrigeration system

- One master control
- The slave EEV control and EEV set are the same as a single refrigeration system.

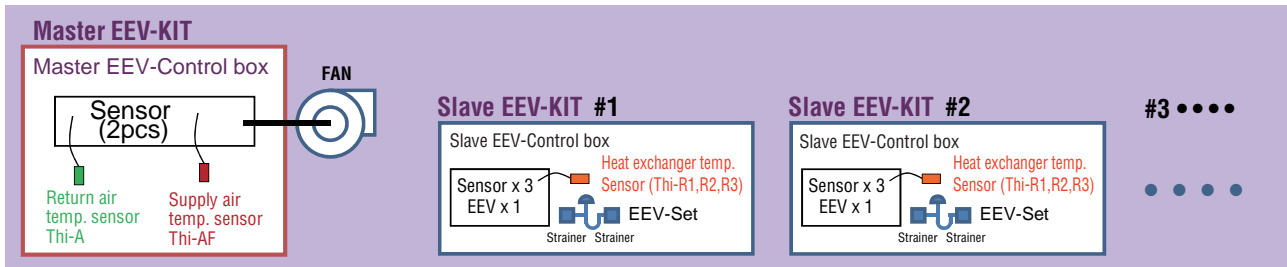
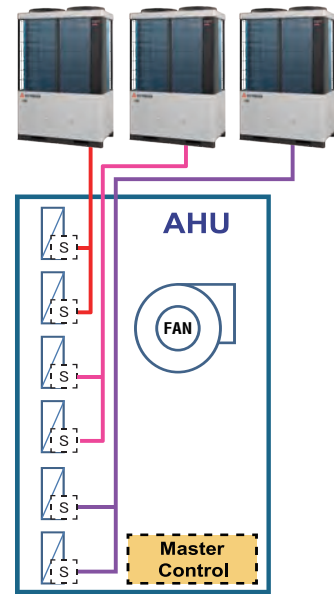

# Connection to SUPERLINK-II

## Single refrigeration system

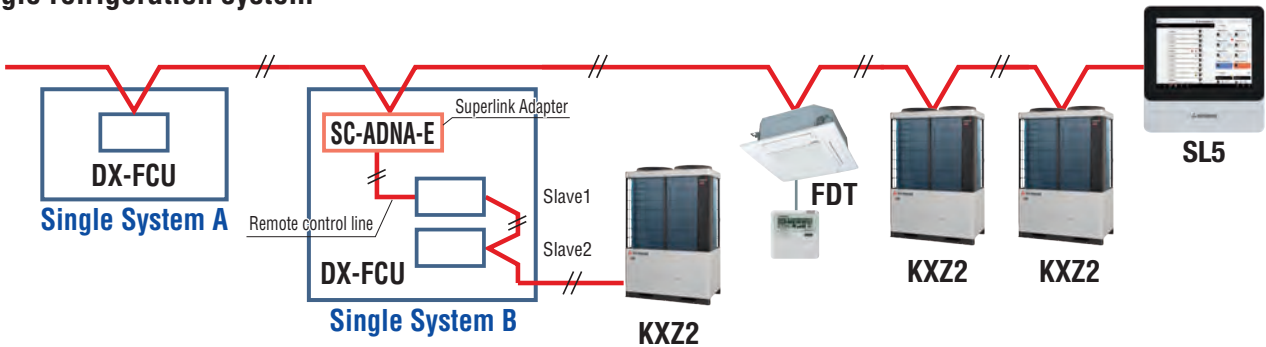

## Multiple refrigeration system

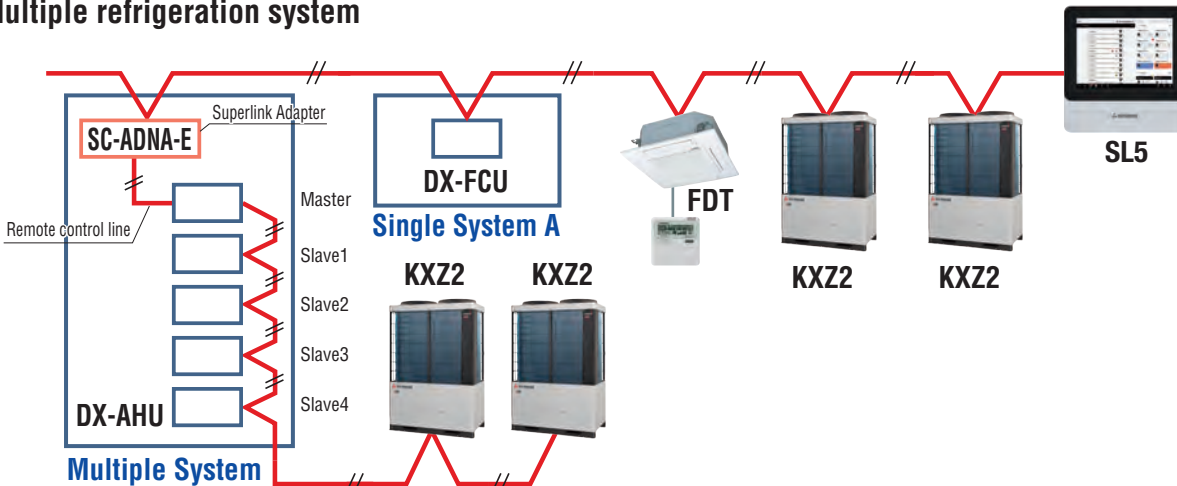

# Control Systems

## Individual control

### Remote Control line up

wired	indoor unit	remote control	wireless	indoor unit	remote control	indoor unit	remote control	indoor unit	remote control
	all models			RC-EX3D	FDT	RCN-T-5BW(-5BB)-E2	FDT5	RCN-TS-E2	FDE
		RC-E5	FDTC	RCN-TC-5AW-E3	FDK22-56	RCN-K-E2	FDLW	RCN-FW-E2	
		RCH-E3	FDTW	RCN-TW-E2	FDK71	RCN-K71-E2	others*	RCN-KIT4-E2	

\*FDTQ, FDU, FDUM, FDUU, FDUH, FDU-F

Wired remote control

(option)

### RC-EX3D

Intuitive touch controller with Liquid Crystal Display

#### User friendly

- LCD panel with light tap operation introduced as the industry's first
- Simple interface with only three buttons

#### Easy view

- Big LCD with 3.8 inch full dot display
- Back light function
- Multi language display (9 languages)

**Operation mode**

- Cooling
- Fan
- Dry
- Heating
- Auto

**Operation mode setting screen**

The desired operation mode can be selected by simply tapping this button.

**Setting temperature screen**

You can select the temperature as desired by tapping ▲▼ button.

**High power operation**  
The highest capacity operation (Max 15 minutes)

- Increasing compressor speed
- Increasing air flow volume

**Energy-saving operation**

- Changes set temperature.  
At 28°C in cooling mode and 22°C in heating mode, 25°C in auto mode.
- Operation correction by outdoor temperature

### Main functions

	Function name	Description
Economy & Timer	Energy-saving operation	Since the capacity is controlled automatically based on the outdoor temperature, energy can be saved without losing comfort.
	Sleep timer	Set the time period from start to stop of operation. The selectable range of setting time is from 30 to 240 minutes (at 10-minute intervals).
	Set temperature auto return	The temperature automatically returns to the previously set temperature.
	Set ON timer by hour	When the set time elapses, the air conditioner starts.
	Set OFF timer by hour	When the set time elapses, the air conditioner stops.
	Set ON timer by clock	The air conditioner starts at the set time.
	Set OFF timer by clock	The air conditioner stops at the set time.
	Weekly timer	On or Off timer can be set on a weekly basis.
	Peak-cut timer	Capacity control can be set by using peak cut function on RC-EX3D for better energy saving. Five-step capacity control is available.
	Home leave operation	When the unit is not used for a long period of time, the room temperature is maintained at a moderate level, avoiding extremely hot or cool temperatures.
Comfort	Big LCD & Touch screen panel	Large 3.8 inch screen has resulted in improved visibility and operability.
	Easy modification of individual flap control	User can visually confirm and set the direction of flaps using the visual display on the remote controller.
	Automatic fan speed *1	The micro-computer automatically adjusts the airflow effectively to follow the changes of return air temperature.
	Temp increment setting	Temperature increment for the change of the set temp can be changed.
Convenience	Silent mode	Set the period of time to operate the Outdoor unit with prioritizing the quietness.
	Function switch	The function switch allows user to select and set two functions among available functions.
	Favourite setting	Operation mode, set temperature, fan speed and air flow direction automatically adjust to the programmed favourite setting.
	Adjusting Brightness of the background light	The brightness of the background light can be adjusted by 10 stages.
	LCD contrast setting	This function allows user to adjust LCD display contrast.
	High power operation	High Power Mode increases the unit operating ability for 15 minutes to quickly adjust the room temperature to a comfortable level.
	Back light setting	This convenient function allows user to see controls under low light conditions.
	Administrator settings	This function only allows specific individuals to operate the unit.
	Setting temp range	Limited range of setting temperature in the heating or the cooling operation can be selected.
	External Input/Output Function	The external input/output of indoor unit by remote controller can set input/output based on user needs.
Service	Select the language	Set the language to be displayed on the remote control.
	USB connection (mini-B)	This function allows batch input of schedule timer settings and other settings involving a large amount of data.
	Error code display	This function allows user to check information displayed when abnormal function of the unit occurs.
	Operation data display	Displays various types of air conditioner operation data in real time.
	Contact company display	Address of the service contact is displayed.
	Filter sign	Announces the due time for cleaning of the air filter.
	Static pressure adjustment	Allows user to adjust duct static pressure using the remote control.
Backup Control	Allows for rotation control, fault backup control, and capacity backup control.	

\*1 Cannot be used when a centralized control remote is connected.

**Wireless remote control**

(option)

For wireless control simply insert the infra-red receiver kit on a corner of the panel

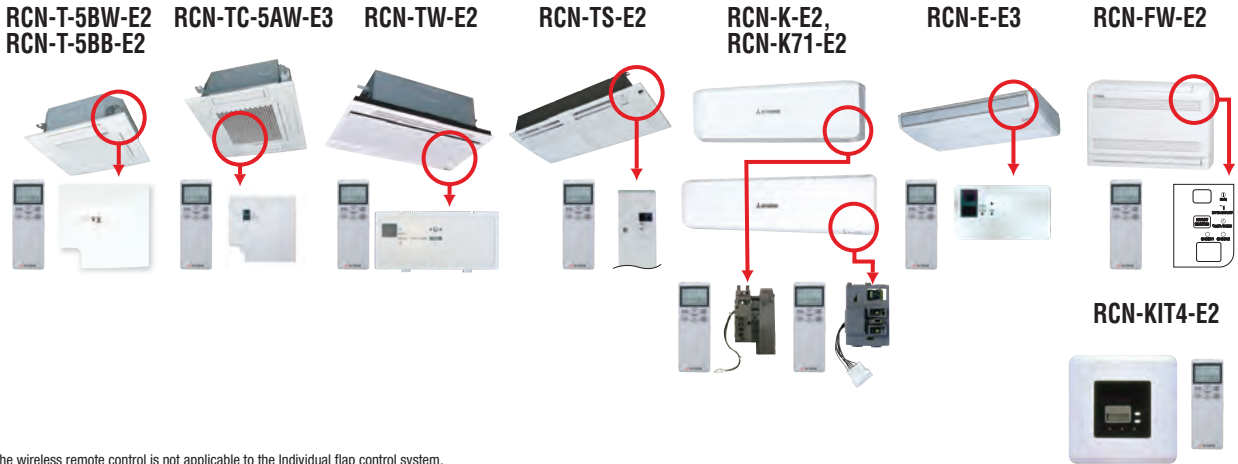

\*The wireless remote control is not applicable to the Individual flap control system.

**Wired remote control**

(option)

**RC-E5**



The RC-E5 controller enables extensive access to service and maintenance technical data combined with easy to use functions and a clear LCD display.

**Run hour meters to facilitate maintenance checking**

RC-E5 stores operation data when an anomaly occurs and indicates the error on the LCD. It also displays cumulative operation hours of the air conditioner and compressor since commissioning.

**Room temperature controlled by the remote control sensor**

The temperature sensor is housed in the top section of the remote control unit. This arrangement has improved the sensitivity of the remote control unit's sensor, which permits more finely controlled air conditioning.



**Weekly timer function as standard**

RC-E5 provides (as a standard feature) a weekly timer, which allows one-week operation schedules to be registered. A user can specify up to four times a day to start/stop the air conditioner. (Temperature setting is also possible with the timer).

**Changeable set temperature ranges**

RC-E5 allows the upper and lower limits of a set temperature range to be specified separately. By adjusting a set temperature range, you can ensure energy saving air conditioning by avoiding excessive cooling or heating.

**Timer operation**

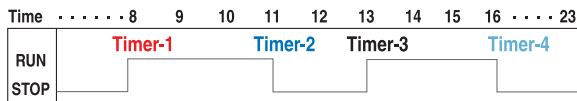

**Changeable range**

Upper limit	20–30°C(effective for heating operation)
Lower limit	18–26°C(effective for non-heating operation)

**Simple remote control**

(option)

**RCH-E3 (wired)**



Designed specially for hotel rooms, the controller's buttons are limited only to the minimum required functions such as ON/OFF, mode, temperature setting and fan speed. It is really simple and easy to use.

**Up to 16 units**

It can control up to 16 indoor units, by pressing the AIR CON No. button.

**AUTO restart**

This function allows starting the air conditioner automatically when power supply is restored after power failure or by turning on the power switch.

\*RCH-E3 is not applicable to the Individual flap control system. 8m  
\*When RCH-E3 is used, the fan speed setting can only be set to 3 speed settings (Hi-Me-Lo).

**Thermistor**

(option)

**SC-THB-E3**

In case the sensor integrated in the indoor unit or in the remote controller is unable to sense the room temperature correctly, or an individual controller in each room is not required but a temperature sensor is (as when a central control system is in place), install SC-THB-E3 in an adequate location in the room.



# Controls network overview

Our company offers simplicity in installation with the highly sophisticated SUPERLINK-II Control System

**This offers building owners and occupiers** a comprehensive control and management system while providing complete commissioning and service maintenance assistance for installers and service engineers. The SUPERLINK-II is an advanced high speed data transmission system which can connect up to 128 indoor units and 32 outdoor units onto one network. A wide range of control options are available for the SUPERLINK-II network to suit any application large or small, as well as connection to a new or existing Building Management System (BMS).

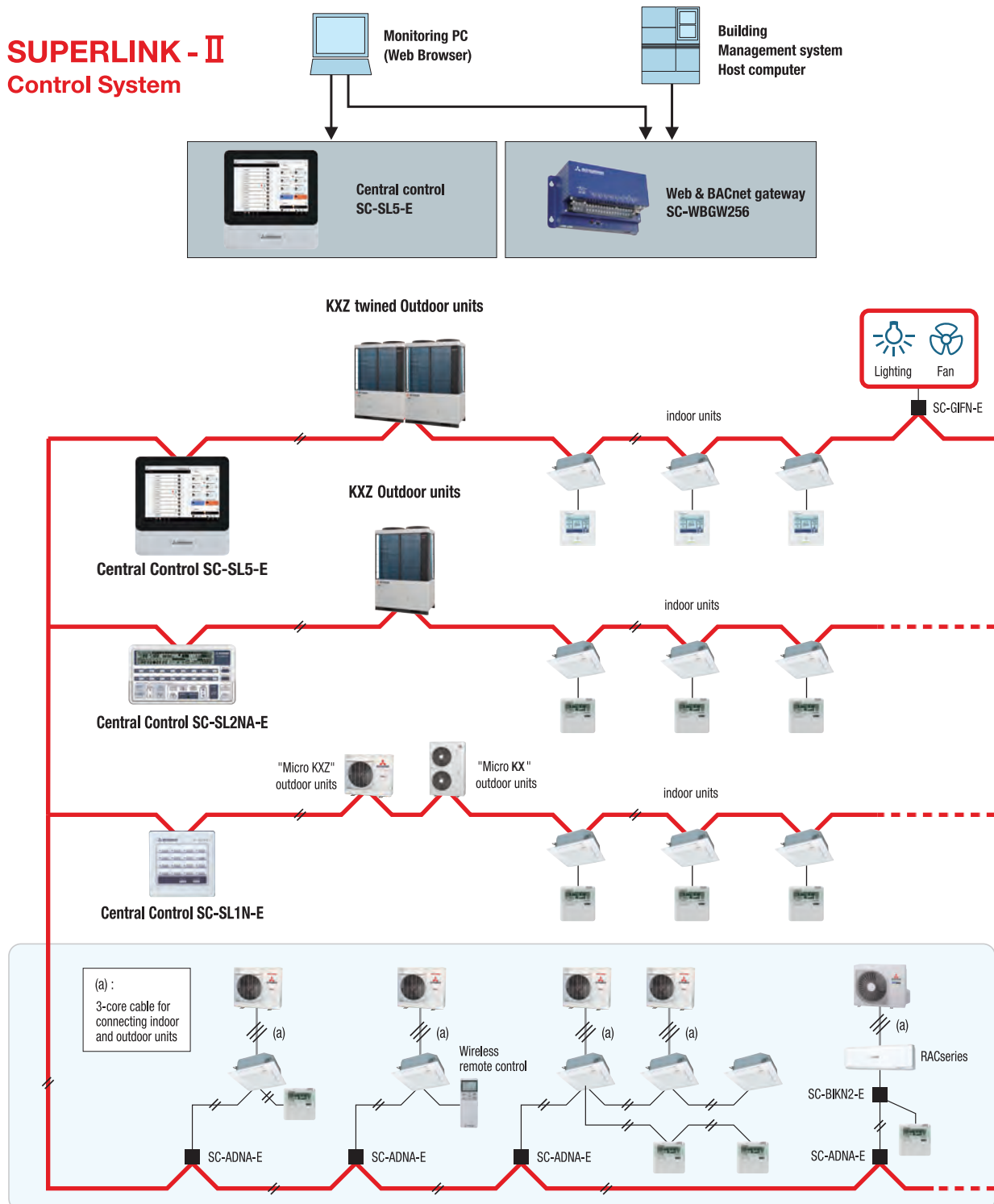

# Central Control

## SC-SL1N-E

Start/stop control of up to 16 indoor units either individually or collectively.  
Simple centralised control.

1. The SC-SL1N-E is connected to the Superlink- II network via 2-core, non-polar wires ('AB' connection).
2. It will monitor and control the start/stop function of up to 16 units, with the sixteen operation button.
3. The unit or group numbers in operation or in need of service are displayed with an LED.
4. Collective start/stop is also available through the simultaneous on/off button.
5. Up to 12 SC-SL1N-E units can be connected to a Superlink- II network (consisting of up to 128 indoor units).
6. If a power failure occurs, the SC-SL1N-E will resume the operation of the system according to a stored operation condition, once power is restored.



## SC-SL2NA-E

Central control of up to 64 indoor units including weekly timer function as standard.

1. The SC-SL2NA-E is connected to the Superlink- II network via 2-core, non-polar wires ('AB' connection).
2. It will monitor and control the start/stop function of up to 16 units, or 16 groups of units, with the sixteen operation buttons.
3. It also monitors and controls the following functions for individual units, groups of units or the complete network: operation mode, set point temperature, return air temperature, louvre position, error code. Air flow and center lock function.
4. The unit or group numbers in operation or in need of service are displayed with an LCD.
5. Collective start/stop is also available through the simultaneous on/off button.
6. If a power failure occurs, the SC-SL2NA-E will resume the operation of the system according to a stored operation condition, once power is restored.
7. The SC-SL2NA-E can be connected to an external timer to facilitate timed on/off cycles.

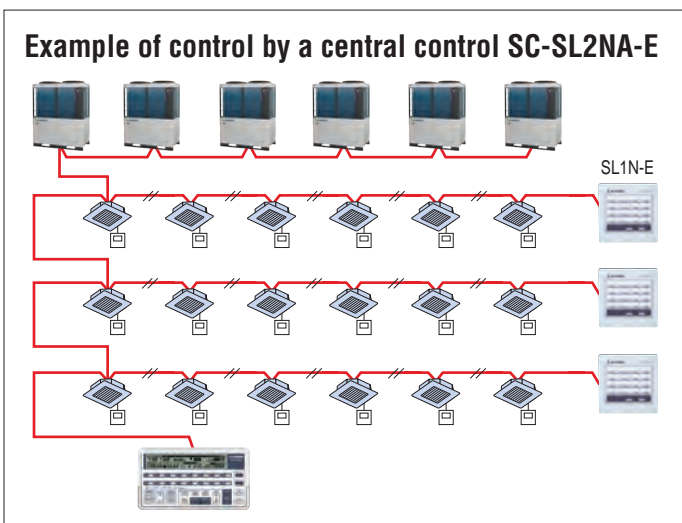
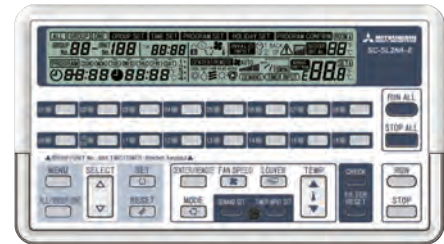

An SC-SL2NA-E performs the start/stop control, monitoring and mode setting of up to 64 units. It is a high quality air conditioner control system that allows up to 64 indoor units to be freely grouped into 1 to 16 groups.

It allows not only the start/stop control but also the monitoring, display of operation statuses such as in operation or in need of service and mode setting such as switching of operation modes of connected units collectively, by group or individually.

• Outer dimensions: H120 x W215 x D25+35\*mm.

35\* is the measurement including the part contained in a recess.

### SC-GIFN-E Interface kit

- Applicable products  
Ventilation fan, Air purifier
- By using SC-GIFN-E together with central control such as SC-SL1N-E, SC-SL2NA-E and SC-SL5-E, you can start-stop, operate & monitor the operation of applicable products.

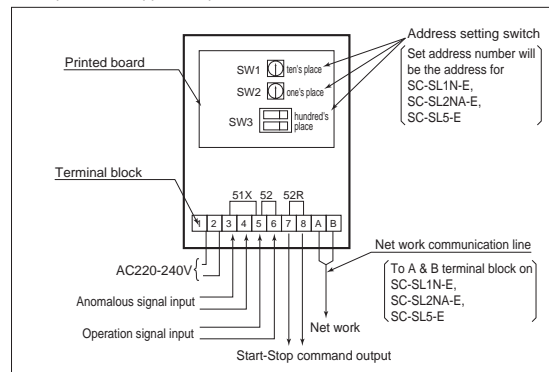

**Note:**Please consult dealer for combination of center controls and Building Management Systems interface units.

New

# Central Control SC-SL5-E

The easy-to-use, initiative interface and monochrome, modern appearance, along with the 10.4-inch Liquid Crystal Display, makes it the perfect solution for environments such as offices or hospitals.

For systems compatible with the SUPERLINK-II protocol, up to **256 units** can be connected.

\*For systems that support only the SUPERLINK protocol, a maximum of 96 units (48 units each SUPERLINK) can be connected.



## 10.4-inch Liquid Crystal Display

External dimensions (Height x Width x Depth)  
280mm x 264mm x 25/50 mm  
Depth: (Wall-embedded / Wall-mounted)



### Specification

Item	SC-SL5-E	
Ambient temperature during use	0 – 40°C	
Power supply	1 Phase 100-240V 50/60Hz	
Power consumption	13W	
External dimensions (Height x Width x Depth)	280mm x 264mm x 25 (+25) mm	
Net weight	2.3kg	
Number of connectable units	Up to 256 units	
LCD touch panel	Colour LCD, 10.4 inches (264mm)	
Inputs	Signal	SUPERLINK (2 systems), SUPERLINK+ Modbus, and SUPERLINK+ RT Protocol
	Watt-hour meter pulse *	8-point, pulse width 80ms or more
	Emergency stop signal *	1 point, non-voltage a contact input continuous input (closed, forced stop)
	Demand signal *	2 point, non-voltage a contact input continuous input (closed, demand control)
Outputs	Operation	All units stop: Open / Any unit operating: Close
	Malfunction	Normal: Closed / Abnormal: Open
	Refrigeration leak detector	Normal: Closed Refrigerant leak: Open



\* Side power supply is DC 12V (10mA).

# System Diagram

- Two independent communication ports are provided (SL4 is equipped with a single port).
- Each port supports independent protocol selection (SUPERLINK / Modbus / RT), allowing up to nine possible combinations.

The SC-SL5-E is compatible with various types of MHI products, including the KX series and Q-ton.

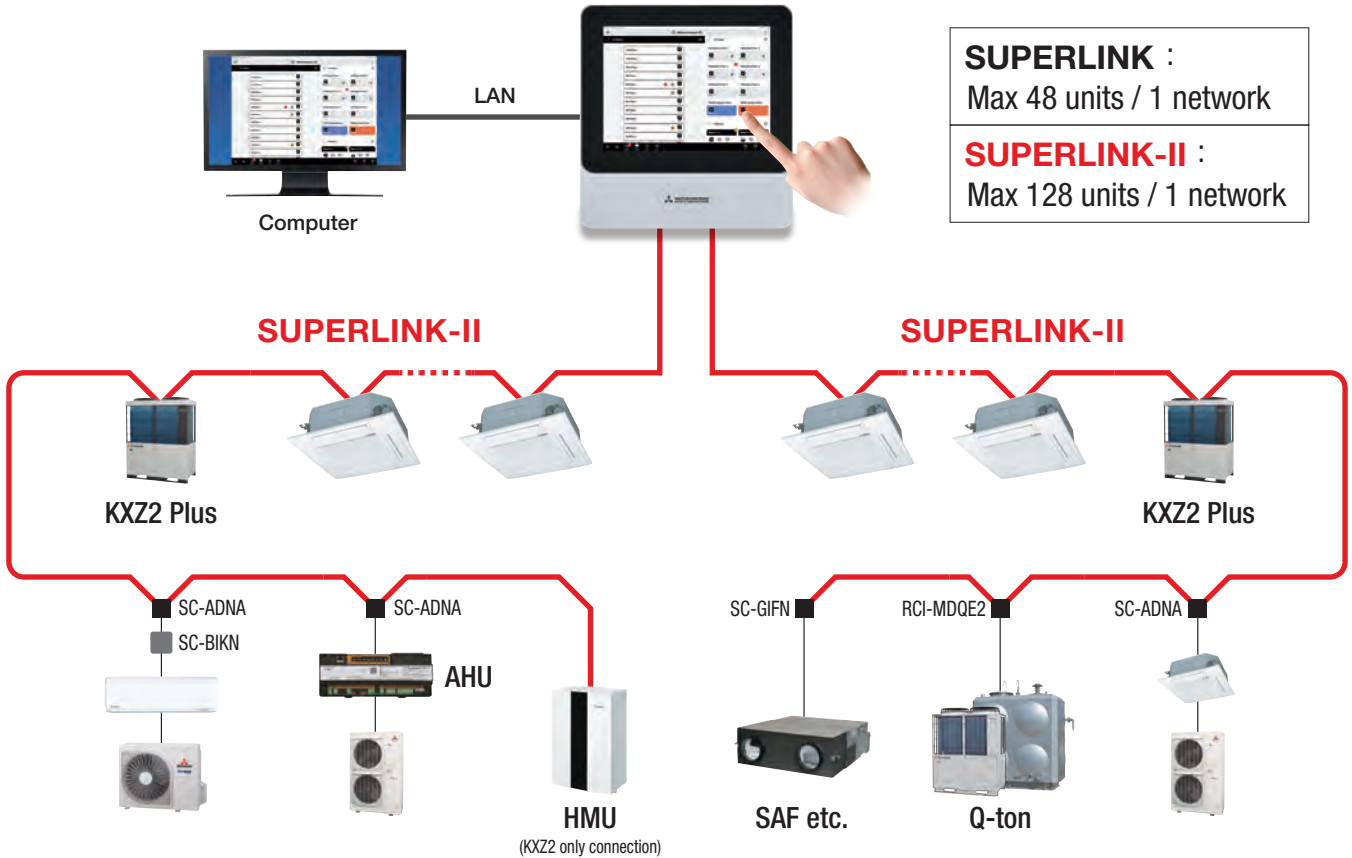

# Installation

Supports both wall-mounted and wall-embedded installation preferences. Both mounting brackets (flat metal plate and embedded frame) are included as standard, allowing for flexible on-site installation. The unit can be easily installed without removing the LCD panel.

## New Wall-mounted

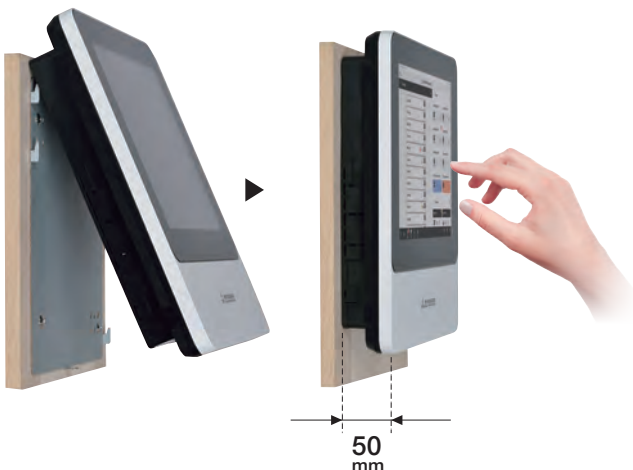

## Wall-embedded



# New Screen Design & Usability

## Touch-Screen Technology

By adopting the same intuitive touch-screen technology as used in smartphones, fingertip operation is possible. For example, you can flick/swipe by touching screen. Additionally, the screen design allows for intuitive operation.



## Unified design across SC-SL5-E, PC web browser screen and M-ACCESS

The SL5 and PC web browser screen share the same dashboard, while M-ACCESS adopts a unified design concept with consistent fonts, colours, and icon styling - ensuring intuitive and seamless usability across the platforms.

## Seamless usability across the platforms



## Unified icon styling



Note:

By setting the IP address, the controller interface can be displayed and operated on a PC.  
 Web browser requirements: Microsoft Edge, Google Chrome, Safari  
 Minimum monitor resolution: 1280x1024 or higher

# Scheduling

The RUN/STOP/AWAY time, operation mode, remote control Lock/Unlock setting, temperature setting, energy setting, and silent mode can be set up to 16 times per day.

In addition, the weekdays, holidays, special day 1, or special day 2\* can be selected and set. The system is also capable of automatically updating the annual schedule.

\*Special days refer to user-defined specific days.

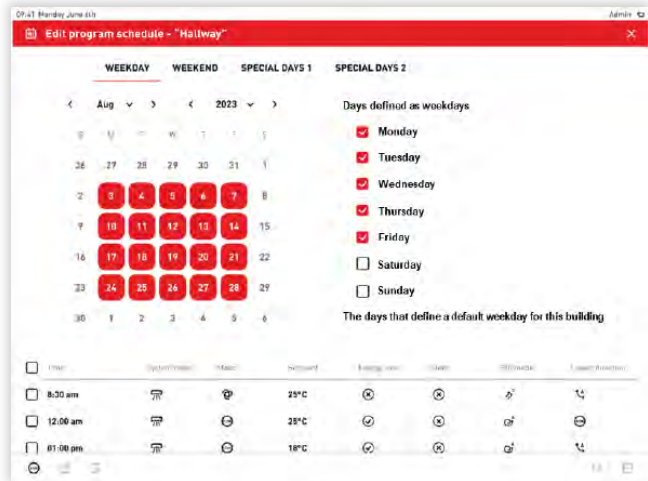

# Operational History

It is possible to review past operational usage for heating and cooling. Additionally, you can also check the usage of other modes such as the fan and dehumidification separately, allowing clear monitoring of power consumption and an easy breakdown by each operation mode.

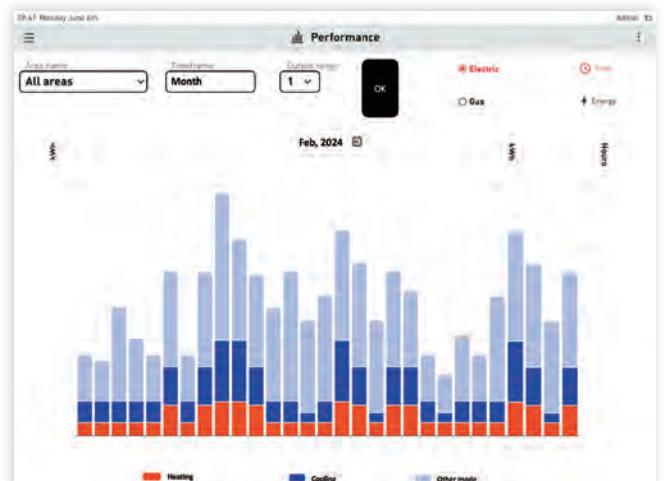

## Configuration of Block

Accurate control can be achieved by selecting various categories such as Block, Group or Floor.

Eg) If there are multiple businesses occupying separate floors, within one communal building, control can be managed separately for each business.

\*Note: Block allows ON/OFF operation only, while Group and Floor enable control of different device types.

### Unit icons and import floor layout

It is also possible to import your floor plan schematics in various formats (JPEG, PNG, BMP) and using the unit icon, position the units in the preferred locations. You may keep adjusting until you achieve your preferred installation layout.

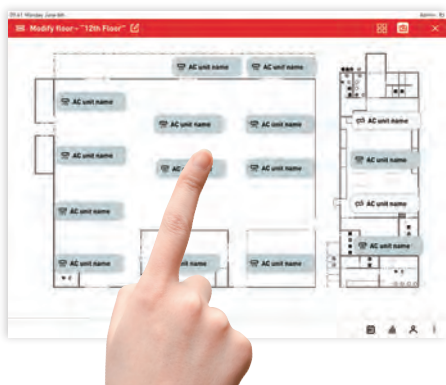

## New classification "Floor"

Units can be registered in both Group and Floor at the same time.

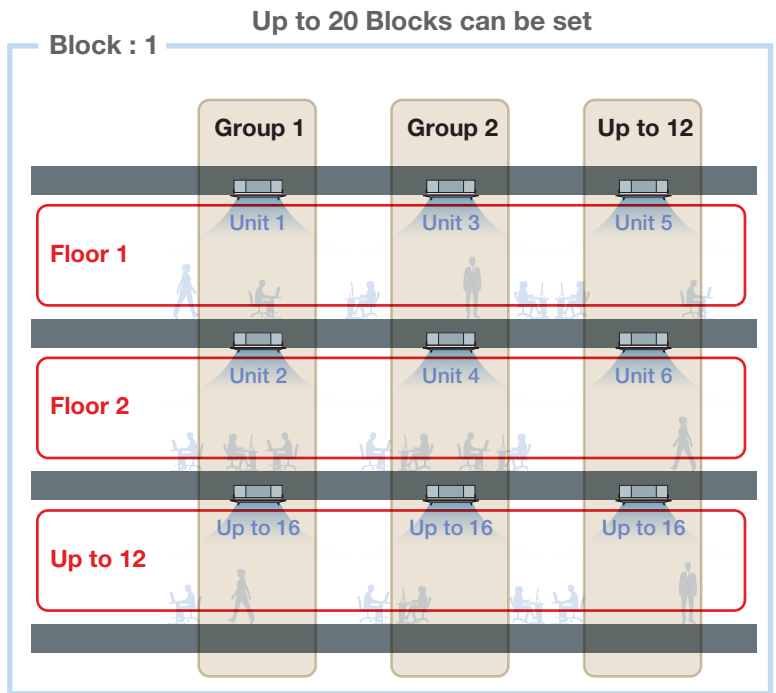

## Demand Control

### Temperature shift control

If the demand controller output sends a signal, the set temperature is automatically adjusted to save energy. The temperature shift value can be set in the setting screen.



### Peak cut control

If the demand controller output sends a signal, SL5 sends signal to the unit to adjust capacity. Capacity adjustments can be made via the setting menu.

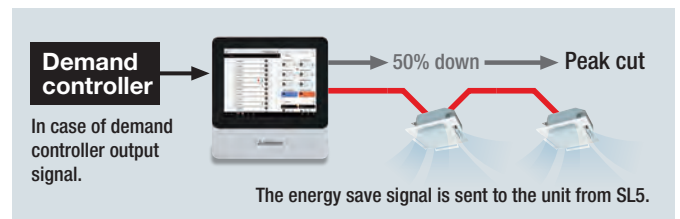

## Power Consumption & Billing Calculation

By connecting external watt-hour meters, SC-SL5-E collects power consumption data (kWh) for each indoor unit, each group, each SUPERLINK system and generates an automatic billing calculation\*. The unit includes standard billing functions, enabling the calculation of electricity rate tables and accounting time periods without the need for external software.

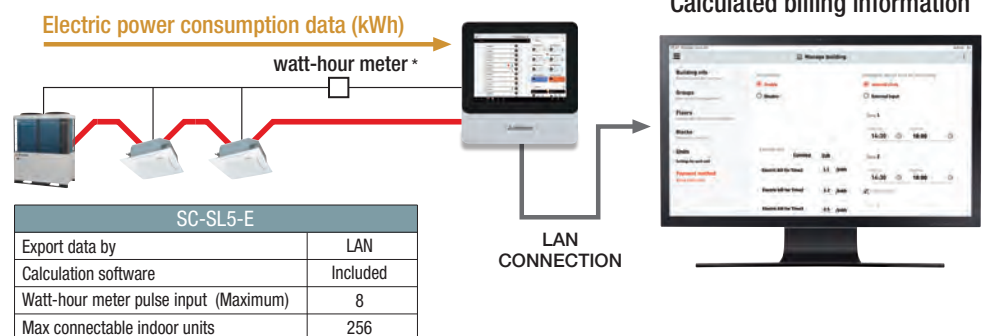

\* Relevant parameters must be set in advance.

\* The watt-hour meter is not included as a standard accessory and needs to be purchased separately, by the customer.

# Building Management Systems

**Our company offers** a wide range of control options for the KXZ system to suit any application, large or small, as well as connection to a new or existing BMS.



## SC-WBGW256 (Web & BACnet gateway)

SC-WBGW256 controls and monitors of up to 256 cells (some cells can have two or more indoor units and total number of indoor units can be up to 256 units) centralised to a network PC using the Superlink- II web gateway. Simple installation is assured with no special software requirements, operation is via Internet Explorer. A low power embedded CPU and compact flash ROM ensure a large storage capacity with high reliability (no moving parts such as a PC fan, etc). An IP address filter function combined with three-level user authentication check also ensures security. Also, SC-WBGW256 can be used as interface devices that convert Mitsubishi Heavy Industries Superlink- II communication data to BACnet code and are controlled centrally from a building management system.

Production by order



### [ In case of web gateway ]

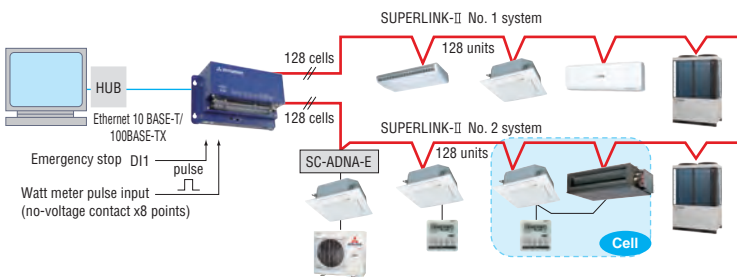

PC requirements: Windows 7, Windows 8.1, Windows 10, Windows 11  
Monitor resolution 1366 x 768 or higher.

### [ In case of BACnet gateway ]

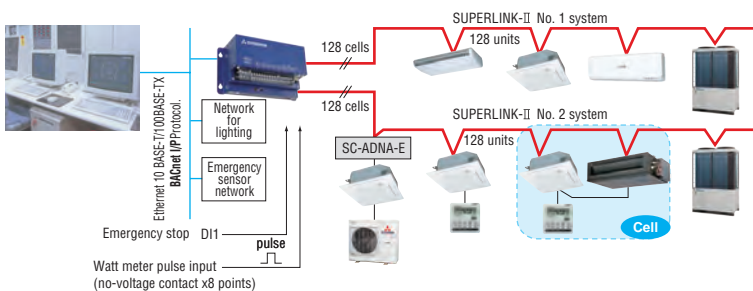

Users can manage up to 1024 units by connecting the four devices!!

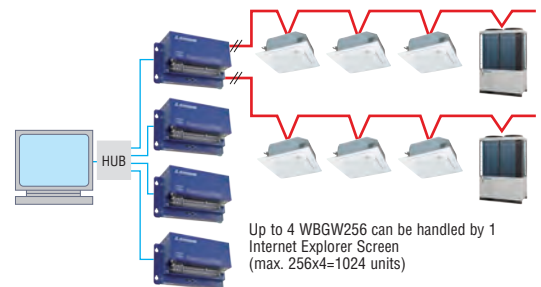

Up to 4 WBGW256 can be handled by 1 Internet Explorer Screen (max. 256x4=1024 units)

# Support tool

## BIM (Building Information Modelling)

We can provide high quality Building Information Modelling (BIM) models in three formats:

1. Revit
2. 3D Cad
3. IFC (IFC provides an interoperability solution between different software applications. The format establishes international standards to import and export building objects and their properties)

How and why BIM is used

BIM enables all disciplines of a project (Architects, engineers, quantity surveyors, contractors, clients etc..) to share a common model and data representing the project they are building.

- Better design visualization
- BIM reduces conflicts and changes during construction
- Increases overall accuracy of project documentation
- Improves cost estimating
- Improves energy analysis
- Simplifies reporting and scheduling

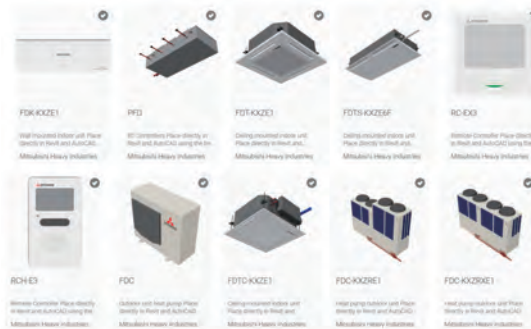

## e-solution

Use our e-solution design software tool to find the latest specifications for our KXZ VRF systems. This software helps to simplify the processes to enable engineers to select the most suitable indoor units, outdoor units, pipework, controls & calculate any additional required refrigerants.

If you're an engineer interested in using e-solution, please register and download the e-solution via <https://mhiae.com/e-solution/> and be sure to download the latest updates when available.

Please be aware that this tool was developed to cater for the design of two and three pipe systems, and specifies the appropriate models and sizes. It also generates wiring diagrams and engineering drawing to export to AutoCAD or PDF. This flexibility allows engineers to print selected design information and technical data to present to potential clients. As well as personalising the design information into their own formats and documents for future proposals.



## MACO Service App

MACO Service application is available & free to download to both IOS and Android devices. The application covers "Mitsubishi Heavy Industries Thermal Systems, Ltd" Air conditioning systems: RAC, PAC & VRF.

This "MACO Service" Application enables field engineers to make:

- A quick search of the meaning of error codes that may appear when there is a malfunction in a "Mitsubishi Heavy Industries Thermal Systems, Ltd" Air conditioning system, the probable cause for the malfunction and troubleshooting guideline.
- Scan the unit's QR code and search the meaning of error codes depending on the model type.
- Additional refrigerant charge calculation for VRF.
- Technical manual, Service manual for RAC, PAC & VRF.
- Technical support Video (Part checking, Troubleshooting, Service Tools, Maintenance data analysis) for RAC, PAC & VRF.
- Spare part information for RAC, PAC & VRF.
- Currently available in English, Japanese, Chinese, Thai, Turkish, Indonesian, Vietnamese, Arabic, Cambodian & Burmese.

To download the App go to:

iPhone: <https://apps.apple.com/th/app/mac0-service/id1276956648>

Android: [https://play.google.com/store/apps/details?id=com.ssd.mac0service&hl=en\\_US&gl=US](https://play.google.com/store/apps/details?id=com.ssd.mac0service&hl=en_US&gl=US)



## Before starting use

### Heating performance

The heating performance values (kW) described in the catalogue are the values obtained by operating at an outdoor temperature of 7°C and indoor temperature of 20°C as set forth in the ISO Standards. Heating performance is reduced as the temperature drops. If the outdoor temperature is too low and the heating performance is insufficient, use other heating appliances as well.

### Indication of sound values

The sound values are the values (A scale) measured in a chamber such as an anechoic chamber following the ISO Standards. In the actual installation state, the value is normally larger than the values given in the catalogue due to the effect of surrounding noise and echo. Take this into consideration when installing.

### Use in oil atmosphere

Avoid installing this unit in an atmosphere where oil scatters or builds up, such as in a kitchen or machine factory.

If the oil adheres to the heat exchanger, the heat exchanging performance will drop, mist may be generated, and the synthetic resin parts may deform and break.

### Use in acidic or alkaline atmosphere

If this unit is used in acidic atmosphere such as hot spring areas having high level of sulfuric gases or in alkaline atmosphere including ammonia or calcium chloride, places where the exhaust of the heat exchanger is sucked in, or at coastal areas where the unit is subject to salt breezes, the outer plate or heat exchanger, etc., will corrode. Please ask a dealer or specialist when you use an air conditioner in places differing from a general atmosphere.

### Use in places with high ceilings

If the ceiling is high, install a circulator to improve the heat and air flow distribution when heating.

### Refrigerant leakage

The refrigerant (R32, R410A) used for air conditioner is non-toxic and in its original state.

However, in consideration of a state where the refrigerant leaks into the room, measures against refrigerant leaks must be taken in small rooms where the tolerable level could be exceeded. Take measures by installing ventilation devices, etc.

### Use in snowy areas

Take the following measures when installing the outdoor unit in snowy areas.

#### · Snow prevention

Install a snow-prevention hood so that the snow does not obstruct the air intake port or enter and freeze in the outdoor unit.

#### · Snow piling

In areas with heavy snow fall, the piled snow could block the air intake port. In this case, a frame that is 50cm or higher than the estimated snow fall must be installed underneath the outdoor unit.

### Automatic defrosting device

If the temperature is low, and the humidity is high, frost will stick to the heat exchanger of the outdoor unit. If continued to use, the heating performance will drop.

The "Automatic defrosting device" will function to remove this frost.

After heating for approx. three to ten minutes, it will stop, and the frost will be removed. After defrosting, hot air will be blown again.

### Servicing

After the air conditioner has been used for several seasons, dirt will build up in the air conditioner causing the performance to drop. In addition to regular servicing, a maintenance contract by a specialist is recommended.

## Safety Precautions

### Air conditioner usage target

The air conditioner described in this catalogue is a dedicated cooling/ heating device for human use.

Do not use it for special applications such as the storage of food items, animals or plants, precision devices or valuable art, etc.

This could cause the quality of the items to drop, etc.

Do not use this for cooling vehicles or ships. Water leakage or current leaks could occur.

### Before use

Always read the "User's Manual" thoroughly before starting use.

### Installation

Always commission the installation to a dealer or specialist. Improper installation will lead to water leakage, electric shocks and fires.

Make sure that the outdoor unit is stable in installation. Fix the unit to stable base.

### Usage place

Do not install in places where combustible gas could leak or where there are sparks. Installation in a place where combustible gas could be generated, flow or accumulate, or places containing carbon fibers could lead to fires.

#### Certified ISO 9001



JQA-0709



Mitsubishi Heavy Industries - Mahajak Air Conditioners Co., Ltd. has been certified of Quality Management System in accordance with ISO 9001 by TUV NORD (Thailand) Ltd.

#### Certified ISO 14001



Mitsubishi Heavy Industries - Mahajak Air Conditioners Co., Ltd. has been certified of Environmental Management System in accordance with ISO 14001 by TUV NORD (Thailand) Ltd.



## Mitsubishi Heavy Industries Thermal Systems, Ltd.

2-3, Marunouchi 3-chome, Chiyoda-ku, Tokyo, 100-8332, Japan

<https://www.mhi-mth.co.jp/en/>

Because of our policy of continuous improvement, we reserve the right to make changes in all specifications without notice.

26KX02E March 2026 F

Edited in Japan